

A global and historical perspective on the exposure characteristics of traditional and new technology diesel exhaust

Impact of technology on the physical and chemical characteristics of diesel exhaust emissions

Truck and Engine Manufacturers Association (EMA)
Association for Emissions Control by Catalyst (AECC)
Manufacturers of Emission Controls Association (MECA)
Conservation of Clean Air and Water in Europe (CONCAWE)
European Automobile Manufacturers' Association (ACEA)



May, 2012

Contact information

CONCAWE

165 Boulevard du Souverain • 1160 Brussels • Belgium

E-mail: info@concawe.org

Tel.: +32 566 91 60

Fax: +32 566 91 81

www.concawe.org

This publication is a joint report by the 2012 IARC Review Stakeholder Group (IRSG):

- Alliance of Automobile Manufacturers (AAM, www.autoalliance.org)
- European Automobile Manufacturers' Association (ACEA, www.acea.be)
- Association for Emissions Control by Catalyst (AECC, www.aecc.be)
- American Petroleum Institute (API, www.api.org)
- CONCAWE (The oil companies' European association for environment, health and safety in refining and distribution, www.concawe.org)
- Truck and Engine Manufacturers Association (EMA, www.truckandenginemanufacturers.org)
- IPIECA (The global oil and gas industry association for environmental and social issues, www.ipieca.org)
- Manufacturers of Emission Controls Association (MECA, www.meca.org)
- International Organization of Motor Vehicle Manufacturers (OICA, www.oica.net)

Note

Considerable efforts have been made to ensure the accuracy and reliability of the information contained in this report. However, neither the contributors, nor their organisations, nor any company participating in these organisations can accept liability for any loss, damage or injury whatsoever resulting from the use of this information. This report does not necessarily represent the views of any company represented in the participating organisations.

Reproduction permitted with due acknowledgement.

ISBN 978-2-87567-000-7



9 782875 670007 >

A global and historical perspective on the exposure characteristics of traditional and new technology diesel exhaust

Impact of technology on the physical and chemical characteristics of diesel exhaust emissions

Truck and Engine Manufacturers Association (EMA)
Manufacturers of Emission Controls Association (MECA)
Association for Emissions Control by Catalyst (AECC)
Conservation of Clean Air and Water in Europe (CONCAWE)
European Automobile Manufacturers' Association (ACEA)



May, 2012

ABSTRACT

This report reviews the global and historical development of exhaust emissions regulations for diesel-fuelled heavy-duty vehicles, passenger cars, and related vehicles as well as the engine, aftertreatment, and fuel technologies that have enabled these vehicles to meet or exceed the prevailing regulations. The impact of these technologies on the physical and chemical characteristics of diesel exhaust emissions is reviewed in detail. In particular, distinctions are made between Traditional Diesel Exhaust (TDE) from older heavy-duty engines and New Technology Diesel Exhaust (NTDE) from newer engines (generally post-2007) on the basis of their physical and chemical characteristics. This information is then put in context with the Monograph Review on engine exhaust that will be conducted by the International Agency for Research on Cancer (IARC) in June, 2012. The technological advances in engines, aftertreatment systems, and diesel fuels over the past 30 years are also described in detail. The report is complemented by extensive references.

KEYWORDS

Diesel, diesel engine, heavy-duty, light-duty, aftertreatment, catalyst, exhaust emissions, particulate matter, PM, PN

TABLE OF CONTENTS

1.0	Overview.....	8
2.0	Introduction.....	11
3.0	Applications of Diesel Technology.....	13
4.0	New Regulations Impacting the Levels and Composition of Diesel Engine Emissions.....	15
5.0	New Technology Diesel Developments Since the Mid-1980s.....	22
5.1	“Transitional” Diesel Technology Development – 1988 to 2006.....	22
5.2	New Technology Diesel Engine Development – 2007 and beyond.....	24
6.0	Carcinogenic Hazard Evaluations: Specific Chemicals versus Complex Mixtures from Evolving Technologies.....	26
7.0	Advanced Collaborative Emissions Study (ACES) of NTDE.....	27
8.0	Quantitative and Qualitative Differences Between NTDE and TDE.....	29
8.1.	Traditional Diesel Exhaust (TDE) PM	29
8.1.1	General Characteristics of TDE PM.....	29
8.1.2	Effects of Engine Operating Conditions and Duty Cycle on TDE PM Composition	30
8.2	NTDE Emissions are Significantly Lower than TDE Emissions.....	34
8.3	NTDE PM has a Significantly Different Composition than TDE PM	37
8.3.1	Significant Reduction of Elemental Carbon and Dominance of Sulfate in NTDE PM	37
8.3.2	Significant Reduction and Elimination of PAHs in NTDE.....	42
8.3.3	Semi-Volatile Organic Fraction (SOF) of NTDE is Significantly Different than TDE SOF.....	48
8.3.4	NTDE Contains Significantly Lower Amounts of Other Unregulated Pollutants than TDE.....	49
8.3.5	Significantly Lower Nanoparticle Emissions in NTDE.....	50
8.3.6	Passenger Cars and NTDE	54
8.3.7	Summary -- NTDE PM is Fundamentally Different from TDE PM	56
9.0	Lack of Unique Markers and Surrogates for Diesel Exhaust Exposures	58
9.1	Historic Difficulties in the Search for Useful Markers and Surrogates for Diesel Exposures.....	58
9.2	Specific Problems in Using CO as a Surrogate for Diesel Exposures: There Is No Cross-Engine Correlation Between CO and PM	59
10.0	Global Adoption of Advanced Diesel Emission Control Standards.....	66
10.1	Vehicle Sales	67
10.2	Vehicle Emissions Requirements.....	67
10.2.1	Base Case.....	68
10.2.2	Forecast Case	70
11.0	Conclusions Regarding TDE and NTDE.....	72

12.0	Bridging from Emissions Characterization to Evaluating Potential Human Health Impacts of Exposure	74
13.0	References	79
14.0	Abbreviations and Other Terms.....	89
15.0	Acknowledgements	94

Appendices:

1. Emission Control Technologies for Diesel Engines
2. Methods for characterizing diesel exhaust and operational factors that can affect the results
3. Potentially confounding nitroarene artifacts in diesel particulate samples

LIST OF TABLES

Table 1: Summary of key regulations in the USA that have stimulated the development of improved diesel engine technology and fuels with markedly reduced exhaust emissions	15
Table 2: Average Regulated Emissions Summary for Four FTP Composite Cycles 1/7*cold-start + 6/7* hot-start), One per ACES Phase 1 2007 Engine (Khalek et al. (2011)).....	34
Table 3: Summary of average unregulated emissions for all twelve repeats of the 16-hour cycles for all four 2007 ACES Engines and for 2004 Technology Engines used in CRC studies E-55/E-59 (dioxins were compared to 1998 levels) (Khalek et al. (2011))	38
Table 4: Organic species emissions comparison from a 2004 HD diesel engine (308.5ppm S diesel fuel) without after-treatment and a 2007 HD diesel engine (9.2ppm S diesel fuel) equipped with a catalyzed DPF system (Liu et al. (2010))	38
Table 5: CARB TACs: average emissions for all twelve repeats of the 16-hour cycles for all four 2007 ACES Engines, and for 1994 to 2000 technology engines running over the U.S. FTP (Khalek et al. (2011))	43
Table 6: PAH and nitro-PAH average emissions for all twelve repeats of the 16-hour cycles for all four 2007 ACES engines, and for a 2000 technology engine running over the U.S. FTP (Khalek et al. (2011))	47
Table 7: Specifications of light-duty diesel vehicles in Rose et al. (2010) study (see also Figures 20 and 21)	54

LIST OF FIGURES

Figure 1:	Two scanning electron micrograph (SEM) images of traditional diesel exhaust (TDE) PM (reproduced from Tschoeke et al. (2010)).	12
Figure 2:	U.S. EPA PM emissions standards for heavy-duty on-road diesel trucks (t) or urban buses (ub) in grams per brake-horsepower-hour (g/bhp-hr) (left axis) and as % of “unregulated” engine emissions (right axis)	19
Figure 3:	U.S. EPA NO _x emission standards for heavy-duty on-road diesel engines in grams per brake horsepower-hour (g/bhp-hour) (left axis) and as a percentage of “unregulated” emissions (right axis).	19
Figure 4:	Schematic rendering of evolutionary development of advanced diesel technology followed by revolutionary advances occurring with introduction of ULSD fuel and wall flow Diesel Particulate Filters (DPF).	23
Figure 5:	Impact of engine operating condition on TDE PAH emissions (appears as Figure 22 in Wall and Hoekman (1984))	31
Figure 6:	Impact of engine duty cycle on NO _x and PM emissions (appears as Figure 26 in Clark (2006))	32
Figure 7:	Relative impact of operating variables on PM emissions (appears as Figure 6 in Clark et al. (2002))	33
Figure 8:	PM emissions for one TDE vehicle and six NTDE vehicles configured with DPFs and SCR systems (data from Herner et al. 2009). Expressed as mg/km on left and as percent of TDE on right. The number at the top of each bar is the PM emissions in mg/mile.	35
Figure 9:	Cummins diesel and natural gas engines and other manufacturers’ gasoline engines emissions over US Federal Certification Test cycle. (Wall (2012))	36
Figure 10:	PM mass emissions for transit buses fuelled with ULSD (NTDE) or compressed natural gas (CNG) and operated with or without a DOC. Emissions in mg/mile on the left and as % of TDE on the right. (data from Hesterberg et al. (2008)).	37
Figure 11:	More than 99% PM reduction with DPF and a substantial shift in chemical composition. EC is substantially reduced in NTDE and sulfate dominates. (data from Liu (2009a))	41
Figure 12:	Measured PM emissions (carbon, volatile organics, sulfate and nitrate) continuously regenerating DPF from a heavy duty diesel engine as a function of fuel sulfur content (adapted from Figure 3 in Kittelson et al. (2006)).	42
Figure 13:	Reduced concentrations of PAH emissions from a 2007 diesel engine with contemporary emission controls compared to emissions from a 2004 engine without contemporary emission controls (Liu et al. (2010)).	45
Figure 14:	Concentration of nitro-PAH from a 2007 model engine with contemporary emission controls compared to 2004 model engines without contemporary emission controls (left), Liu et al. (2010) and 2007 model (ACES engines) compared to 2000 model engines (right) (Khalek et al. (2009, 2011)).	46
Figure 15:	Concentration of oxy-PAH from a 2004 model engine without exhaust after-treatment compared to 2007 model with contemporary controls (Liu et al. (2010)).	47
Figure 16:	Average particle phase semi-volatile emission rate and composition for all twelve repeats of the 16-hour cycles using all four ACES engines (Khalek et al. (2011))	49
Figure 17:	Average PN emissions comparison between 2007 ACES engines with and without C-DPF regeneration and a 2004 technology engine without DPF or DOC (Khalek et al. (2011)). Note that the y-axis is a logarithmic scale.	51

Figure 18: Average particle size distribution comparison between four 2007 ACES engines with and without C-DPF regeneration and a 2004-technology engine without a DOC or C-DPF (adapted from Khalek et al. (2011)). Note that the y-axis is a logarithmic scale.	51
Figure 19: Normalized total PN emissions during the entire U.S. FTP cycles for a 1992 TDE and a 2004 engine equipped with an EGR system operating on either ULSD (<15ppm S) and low-sulfur (308ppm S) diesel fuel, with flow rates of 0.7 or 1.3m ³ /S (Liu et al. (2007)).	53
Figure 20: Solid PN emissions from three European passenger cars (Rose et al. (2010))	55
Figure 21: Total PM mass and composition from three European passenger cars (Rose et al. (2010))	55
Figure 22: Poor correlation between PM and CO (Xu et al. (2005)).....	59
Figure 23: Cycle-specific PM against CO for tests on vehicles with Pre-1994 engines evaluated at 56,000 lb inertial weight over the UDDS driving schedule (appears as Figure 17 in McKain (2012)).	61
Figure 24: Cycle-specific EC fraction of PM versus CO for trucks with 1950-1975 model year diesel engines (appears as Figure 35 in McKain (2012)).....	62
Figure 25: PM-CO linear correlation for all Cummins engines tested over the EPA HD transient and ramped modal cycles for PM between 0.1 and 0.5 in four CVS cells at the Cummins Technical Center in calendar year 2009 (Martin (2012)).....	63
Figure 26: CO-average horsepower linear correlation for all Cummins engines with average hp above 25 tested over the EPA HD transient cycles in four CVS cells at the Cummins Technical Center in 2009 (Martin (2012)).	63
Figure 27: Log PM – Log CO correlation for all Cummins engines tested over the EPA HD transient and ramped modal cycles for PM between 0.1 and 0.5 in four CVS cells at the Cummins Technical Center in 2009 (Martin (2012)).	64
Figure 28: Scatter plot and regression analysis between natural-log transformed (Ln) CO and REC measurements for all mining facilities combined (from Fig.2, Vermeulen et al. (2010a), (2010b)).	64
Figure 29: Global transition to more stringent emission standards over time (O’Keefe (2012)).	66
Figure 30: Current and projected global diesel fuel sulfur limits (O’Keefe (2012)).	67
Figure 31: Base case: Global trends in Heavy Duty Diesel emission standards – millions of vehicles worldwide. (Walsh (2012))	69
Figure 32: Base case: Global trends in Heavy Duty Diesel emission standards – percentage of vehicles worldwide. (Walsh (2012)).	69
Figure 33: Forecast case: Global trends in Heavy Duty Diesel emission standards – millions of vehicles worldwide (Walsh (2012)).	70
Figure 34: Forecast case: Global trends in Heavy Duty Diesel emission standards – percentage of vehicles worldwide (Walsh (2012))	71
Figure 35: Forecast 2020 Heavy Duty Diesel emission standards – percent of vehicles worldwide. (Walsh (2012))	71
Figure 36: Relevant exposure times of epidemiological studies published to date compared to time of first particulate emission regulations. All studies fall into the unregulated time period.....	77

1.0 OVERVIEW

This report provides background information relating to the evolution of diesel engines and diesel engine exhaust in support of the anticipated International Agency for Research on Cancer (IARC) Monograph on the Evaluation of Carcinogenic Risks to Humans from “Diesel and gasoline engine exhausts and some nitroarenes” (IARC Monograph Vol. 105). The document focuses on the changes in diesel engine technologies over the past two decades, and analyzes in some detail the dramatic transformations that have occurred in diesel exhaust mass emissions and chemistry due to the more recent advent (2007 in the US) of diesel particulate filters, together with exhaust oxidation catalysts and ultra-low sulfur fuel, all in response to extremely low technology-forcing particulate emission standards. The implications of these revolutionary technological advances on the relevance of the estimated levels of exposure to “traditional” diesel engine exhaust in past epidemiological studies are also discussed.

Epidemiological studies of occupational exposures to diesel engine exhaust are by their nature retrospective, often involving exposures to technologies characteristic of diesel engines several decades in the past. Furthermore, epidemiology studies often pertain to a specific occupation with workers who are exposed to a specific machine application (e.g., railroad locomotive, mining equipment, transit bus); a specific duty cycle (e.g., idling or moving in maintenance facilities); and a specific geopolitical region, which, along with local economic conditions, will determine the applicable emission regulations governing the diesel engines at issue, as well as the age of the equipment and the maintenance practices utilized. For these reasons, this paper will also address the impact of engine application, duty cycle and emission control technology on the composition of diesel engine exhaust.

The principal focus, however, will be on engine technologies that impact the composition of diesel particulate emissions, since that emission constituent has been the distinguishing feature of diesel exhaust most frequently highlighted in diesel-specific health and epidemiological studies.

For convenience and clarity in discussing the significant changes in diesel engine technology over time, we employ the terminology coined by Hesterberg et al. (2005). Specifically, we will refer to the exhaust emissions from diesel engines which employ wall-flow exhaust particulate filters and exhaust oxidation catalysts, and which operate on ultra-low sulfur diesel (ULSD) fuel as ‘New Technology Diesel Exhaust’ (NTDE). Exhaust from on-highway engines predating 1988 in the US, and Euro I in the rest of the world (e.g., 1992 in Europe), will be referred to as ‘Traditional Diesel Exhaust’ (TDE). The exhaust from diesel engines

manufactured in the U.S. between 1988 and 2006, and from Euro I to Euro V engines in the rest of the world, will be referred to as “transitional diesel exhaust.” Over that transitional time period, particulate emission mass and chemical composition changed in a marked and evolutionary way. However, as detailed below, the revolutionary step-change came in 2007 with the advent of NTDE, because new technology diesel engines have incorporated not only the transitional particle reductions that had been occurring since 1988, but also have integrated a particulate filter and oxidation catalyst that target the full range of diesel exhaust chemical compounds (McClellan (2012)).

While there were emission controls in place for diesel engines prior to 1988 (and Euro I), the emphasis was primarily on oxides of nitrogen (NO_x), carbon monoxide (CO), and hydrocarbon (HC) emissions. Particulate emission control was accomplished only indirectly through standards for visible smoke. Thus, particulate emissions from on-highway diesel engines were unregulated until 1988 in the US and 1992 in Europe. Industrial and off-road (including marine and locomotive) engine emission standards generally lag on-highway engine standards by several years -- the first non-road particulate standards appeared in 1996 in the US and in 1999 in Europe. Because of the significant impact that different diesel technologies have on the character of diesel emissions, the emission technologies incorporated in the diesel engines under consideration in any epidemiological or toxicological study must be identified carefully and specifically. In that regard, and given the fact that engines manufactured before the above dates were unregulated for particulate emissions, it should be noted that all diesel engines covered by the exposure periods at issue in the various epidemiological studies conducted to date, including the recently published NCI/NIOSH ‘Diesel Exhaust in Miners Study’ (DEMS) (Attfield et al. (2012); Silverman et al. (2012)), fall into the ‘unregulated particulate’ category. None of those studies involved exposures to or assessments of NTDE.

Indeed, because the most advanced diesel technologies and improved fuels have only recently been introduced on a wide-spread basis, no epidemiological studies have been conducted focusing on NTDE. Moreover, the very low concentrations of potentially hazardous chemicals in NTDE relative to the concentrations of those or similar chemicals from other sources in the workplace and ambient environment suggest that it may not be feasible to conduct epidemiological studies of NTDE, even when the new technology has largely displaced the old traditional diesel technology.

The key observations and conclusions that will be discussed in this document are:

- New Technology Diesel Exhaust (NTDE), specifically, exhaust from diesel engines equipped with exhaust oxidation catalysts and wall-flow particulate filters and operating on ULSD fuel, is substantially different in particulate matter (PM) concentration and particulate chemical composition from Traditional Diesel Exhaust (TDE) and should be evaluated separately.
- Recognizing the significant differences in NTDE compared to TDE will encourage faster global adoption of advanced emission control technologies that reduce potential health effect concerns.
- Surrogates for direct measures of diesel exhaust exposure have been a goal for years due to the difficulty of measuring diesel exposure directly. To date, no valid surrogate has been identified, including recent attempts to use CO. This calls into question the exposure estimates and numerical risk factors reported in the DEMS study.

The dramatic improvement of NTDE over TDE does not mean that TDE or transitional diesel exhaust warrant a higher risk or hazard classification than is currently in place. To the contrary, and as detailed in the recent paper of Hesterberg et al. (2012), the available epidemiological, toxicological and mechanistic data are not sufficient to support an increase in the current hazard classification (Group 2A) for TDE and transitional diesel exhaust.

It should also be noted that, just as has occurred over the past two decades, diesel engine systems and fuels continue to improve, and advanced-technology emission reduction strategies continue to evolve. To the extent that other integrated advanced-technology diesel systems are developed that are capable of achieving an exhaust emissions profile for regulated and unregulated pollutants that is sufficiently equivalent to that for NTDE, the exhaust from those alternative advanced-technology diesel systems should be deemed as included within the scope of NTDE.

This document has been structured to include the points most salient to the IARC review process, with other technical details covered in the attached appendices and references.

2.0 INTRODUCTION

Diesel engine exhaust is a complex mixture of carbon dioxide (CO₂), oxygen (O₂), nitrogen (N₂), NO_x, CO, water (H₂O) vapor, sulfur compounds and numerous low and high molecular weight HCs, and PM. As will be discussed in this report, the relative contribution of each of these compounds or classes of compounds has changed with advances in engine and fuel technology. Most of the information pertains specifically to on-highway engines and most is from the US. Nonetheless, it is reasonable to generalize the effects of these on-highway technologies to other applications since they have been or are being applied to numerous stationary and non-road engines as well. The trends in mass emissions and qualitative changes in chemical constituents that result from the technological changes in engines and fuels will be similar for all diesel engines over time, regardless of their applications.

In this paper, we briefly recount the key regulatory issues of concern pertaining to diesel engines and fuels, focusing on emission limits and the characterization of diesel exhaust with regard to its potential carcinogenicity. As noted, we focus primarily on regulations and standards promulgated in the United States. However, similar regulations also have been promulgated in Europe and in other economically advanced countries around the world (Bauner et al. (2009)). Expanding environmental concerns have resulted in regulatory pressure around the globe to develop new technology diesel engines and fuels which produce markedly lower exhaust emissions. Hesterberg et al. (2005) coined the term, “New Technology Diesel Exhaust” (NTDE) to describe the emissions from post-2006 U.S. on-highway diesel engines and from earlier model diesel engines retrofitted with exhaust after-treatment devices (filters and catalysts) and using ultra-low sulfur fuels. In contrast, “Traditional Diesel Exhaust” (TDE) refers to emissions from on-highway diesel engines sold and in use prior to the U.S. EPA 1988 Heavy-Duty Diesel Emission Particulate Standards. “Transitional” diesel engines were marketed in the U.S. from 1988 through 2006, a period of continuous evolutionary improvements in diesel engine and aftertreatment technology. Prior to 1988 in the US and 1992 in Europe, particulate emissions from diesel engines were largely unregulated except indirectly through visible smoke standards.

This document specifically highlights the quantitative and qualitative differences between NTDE and TDE. The aggregates of elemental carbon (EC) nanoparticles with associated HCs – which are the dominant emissions constituent and characteristic feature of TDE – are shown in **Figure 1**. In contrast, the PM emissions in NTDE are substantially lower (less than 1%) than those emitted from 1988 engines. More importantly, EC has been reduced to well below 1% of TDE levels and is approaching and sometimes below the limits of detection,

such that NTDE can be considered to have *de minimis* amounts, if any, of the EC particles found in TDE. The specific chemical constituents found in TDE are also substantially reduced in concentration or eliminated in NTDE. The changes in composition and concentration are so significant that the characteristics and effects of NTDE should be considered separately from TDE.

Figure 1: Two scanning electron micrograph (SEM) images of traditional diesel exhaust (TDE) PM (reproduced from Tschoeke et al. (2010)).

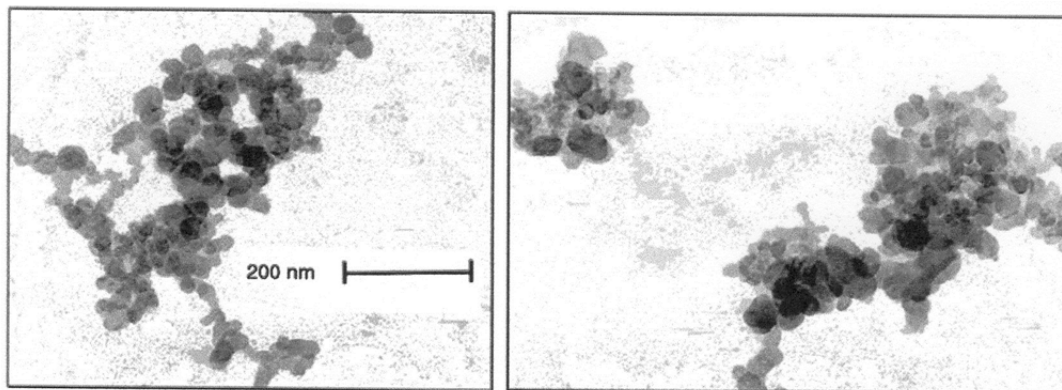

As shown in these images, primary particles having diameters less than about 10 nanometers have aggregated to a size distribution that is log-normal and with median diameter of approximately 80-100 nanometers. The EC particles can adsorb and absorb hydrocarbons, sulfates and trace metals.

The dramatic improvement of NTDE over TDE does not mean that TDE or transitional diesel exhaust represent a higher risk or hazard classification than is currently in place. To the contrary, and as detailed in the recent paper of Hesterberg et al. (2012), the available epidemiological, toxicological and mechanistic data are not sufficient to support a change in the current hazard classification (Group 2A) for TDE and transitional diesel exhaust.

3.0 APPLICATIONS OF DIESEL TECHNOLOGY

Diesel engines are fundamentally more efficient thermodynamically than gasoline engines. Because they operate unthrottled, the air pumping losses associated with gasoline engine air-fuel ratio (AFR) and power control by intake throttle are not present in diesel engines. Furthermore, since a diesel engine compresses only air, it is not knock-limited like a gasoline engine, so it is possible to operate at much higher compression and expansion ratios, further enhancing thermodynamic efficiency. The difference is profound. Depending on duty cycle, diesel engines deliver 30% or greater reductions in fuel consumption compared to gasoline engines. And for any duty cycle, a diesel engine will always be more efficient than gasoline or other spark ignited engines.

The comparative fuel efficiency advantage of a diesel engine is offset to some degree by weight and initial cost. As a result, the "total cost of ownership" must be considered. Nonetheless, the greater the fuel consumption (i.e., more miles or work done) in a year, the more likely the fuel efficiency of a diesel engine will offset its initial cost.

When Rudolf Diesel first invented his "Economical Heat Motor," patented in 1898 and thereafter bearing his name, the consensus was that diesel engines were suitable only for stationary applications because of their size and weight. (Cummins (1993)). Over the next decade, diesel engines were utilized in marine applications, and then moved into trucks in Europe in the 1920s. Not long after, Clessie Cummins, a mechanic and entrepreneur, and the founder of Cummins Engine Company, demonstrated the feasibility of using diesel engines in passenger cars in the U.S. In 1930, diesel power in the US was "off to the races" as Clessie Cummins set the first American land speed record for a diesel car, and produced the first car of any kind to complete the Indianapolis 500 mile race nonstop. Those events transformed the image of the diesel engine from a heavyweight power source suitable only for stationary applications and ships, to a legitimate source of power for automotive applications, and at the same time demonstrated the very significant fuel economy advantage of diesel engines compared to gasoline engines. By 1931, Cummins was deploying diesel engines in commercial trucks and buses (Cummins (1967); Cummins (1993)), and other US manufacturers soon followed.

From those early applications, diesel engines grew into the internal combustion engine of choice for commercial vehicles and industrial applications – especially where durability, high load factor and fuel economy were critical product attributes. Diesel engines displaced steam power in railroad locomotives by the early 1950s, and displaced gasoline engines from most heavy duty trucks by the 1960s.

Today, diesel engines power all types of automotive vehicles: passenger cars (up to 50% of new car sales in some European countries); commercial vehicles; buses; industrial, agricultural and construction equipment; mine trucks; locomotives; ships; and many stationary power applications. Technological developments that contributed to improved exhaust emissions (discussed in detail below) also enabled improvements in power density, fuel efficiency, performance and durability – all important attributes of diesel engines compared to other internal combustion engines. While a number of diesel engine designs emerged in the early years, all of those variations have converged on an engine architecture of choice, as will be described in **Section 5**.

4.0 NEW REGULATIONS IMPACTING THE LEVELS AND COMPOSITION OF DIESEL ENGINE EMISSIONS

Pursuant to the legislative framework of the Clean Air Act, the U.S. Environmental Protection Agency (EPA) has issued a series of regulations (**Table 1**) that have impacted the development and deployment of new technology diesel engines and equipment, and the use of improved ultra-low sulfur diesel fuel.

Table 1: Summary of key regulations in the USA that have stimulated the development of improved diesel engine technology and fuels with markedly reduced exhaust emissions¹

Year	Regulation
1968	First “smoke standard” promulgated for on-road heavy-duty diesel engines (HDDE)
1970	Clean Air Act (CAA) Amendments passed with provision for establishing National Ambient Air Quality Standards (NAAQS) for criteria pollutants, regulation of hazardous air pollutants and provisions for setting emission limits for sources including diesel-powered equipment.
1971	EPA issues NAAQS for PM, Photochemical Oxidants, HC, NO _x , CO and Sulfur Dioxide (SO ₂).
1974	EPA issues regulations for CO and combined HC + NO _x emissions from HDDE
1986	EPA implements new NO _x regulation (10.7g/bhp-hr) for on-road HDDE to replace combined HC and NO _x standard.
1987	EPA issues regulations with reduced PM emission limits of 0.2g/mile and 0.26g/mile for light-duty diesel cars and engines (LDDE), respectively.
1988	EPA introduces the first HHDDE PM emission standard of 0.60g/bhp-hr.; NO _x limit is set at 10.7g/bhp-hr
1991	EPA issues regulations reducing PM emissions to 0.25g/bhp-hr for HDDE in trucks and urban buses and reducing NO _x emissions to 5.0g/bhp-hr.
1993	EPA reduced PM emissions to 0.1g/bhp-hr beginning with 1994 model year

¹ See EPA’s Office of Transportation and Air Quality website for details (<http://www.epa.gov/otaq>)

	and sets highway diesel fuel standards of less than 500ppm sulfur (S) and 35% by weight of aromatic HCs.
1994	<p>EPA reduces PM emissions limit to 0.1g/bhp-hr and 0.07g/bhp-hr for on-road HDDE for trucks and urban buses, respectively.</p> <p>EPA issues TIER 1 emission standards for CO, HC, PM, NOx and smoke emissions for non-road diesel engines at or above 37kW. EPA TIER 1 standards for light-duty vehicles phased in over 1994-1997.</p>
1997	<p>EPA establishes new emission limits for model year 2004 and later truck and bus HDDE, targeting NOx and Non-Methane HC (NMHC) using two alternative standards (either a combined NOx + NMHC limit of 2.4g/bhp-hr or a NOx limit of 2.5g/bhp-hr and a NMHC limit of 0.50g/bhp-hr.</p> <p>EPA promulgates exhaust emission standards for NOx, HC, CO, PM and smoke for newly manufactured and re-manufactured locomotives and locomotive engines.</p> <p>EPA issues NAAQS using PM less than 2.5 microns (PM_{2.5}) as indicator.</p>
1998	EPA sets emission standards for new diesel engines used in non-road construction, agricultural, airport and industrial equipment and certain marine applications.
1999	EPA sets NOx and PM emission standards for large marine diesel engines in U.S. waters.
2000	<p>EPA issues "2007 Heavy-Duty Highway Rule," establishing updated emission limits for 2004 and later heavy-duty engines and vehicles and highway diesel fuel (ultra-low sulfur diesel (ULSD) fuel with sulfur at or below 15ppm S).</p> <p>Mine Safety and Health Administration (MSHA) issues final rule establishing diesel PM (DPM) limits for underground metal and non-metal mines (400µg total carbon/m³ effective July 2002 and 160µg/m³ effective January 2006.</p>
2002	EPA issues first emission standards (combined HC + NOx, PM, and CO) for recreational marine diesel engines over 37kW.

2003	EPA issues final rule for NO _x for new (2004 or later) commercial marine diesel engines (Categories 1, 2 and 3).
	USA Clean School Bus program initiated to reduce children's exposure to diesel exhaust.
2005	MSHA issues final rule with revisions to its DPM concentration limits for underground metal and non-metal miners, replacing the interim DPM concentration limit with a permissible exposure limit (PEL) of 380µg/m ³ measured as elemental carbon (70 FR 32868).
2006	Effective year of US EPA's 2001 standard for highway ULSD fuel.
	MSHA publishes a final rule phasing in the DPM final concentration limit of 160µg/m ³ total carbon over a two-year period based on feasibility with a final commence data of May 20, 2008.
2007	US EPA 2001 PM emissions standard for new heavy-duty engines 0.01g/bhp-hr goes into effect, beginning of phase-in of updated standards for NO _x and NMHC of 0.20g/bhp-hr and 0.14g/bhp-hr. Non-road diesel engines, including locomotive and smaller marine engines now required to use low sulfur diesel (500ppm S) fuel with eventual goal of using ULSD fuel.
	EPA issues a more stringent PM _{2.5} NAAQS, 24-hour averaging time, reduced from 65µg/m ³ to 35µg/m ³ and maintain annual standard of 15µg/m ³ .
2008	US EPA finalizes more stringent emissions standards for locomotive and marine diesel engines including Tier 3 and Tier 4 standards intended to reduce PM and NO _x emissions by 80-90% and the first national emission standards for existing marine diesel engines.
	EPA issues more stringent NAAQS for ozone, reducing 4 th highest 8-hour average over 3 years from 84ppb to 75ppb.
2010	USEPA 2001 updated NO _x and NMHC emissions standards to be in full effect.
	USEPA finalizes rule adding two new tiers of Category 3 (C3) marine diesel engine emission standards (Tier 2 and Tier 3 standards for NO _x , HC, and CO)

and revising its standards for marine diesel fuels produced and distributed in the United States; Non-road diesel engines now required to use ULSD fuel.

2011 EPA revises rules for standards of performance for new stationary compression ignition (diesel) internal compression engines differentiating between engines with displacement greater than or equal to 10 liters per cylinder and less than 30 liters per cylinder and engines with displacement at or above 30 liters per cylinder and also engines operating in remote areas of Alaska.

2012 Effective year for requirement that locomotives and smaller marine engines use ULSD fuel.

These regulations that were promulgated after the earlier IARC Monograph Vol. 46 (1989) can be summarized as follows:

- (i) diesel fuel sulfur levels for on-road vehicles have been reduced to 500ppm S, and more recently (i.e. 2006) to less than 15ppm S (ULSD) in the U.S. and less than 10ppm S in Europe;
- (ii) Heavy-duty On-Highway (HDOH) diesel engine PM emission standards have been reduced by more than 98%, from 0.60g/bhp-hr to 0.01g/bhp-hr (see also **Figure 2**);
- (iii) HDOH diesel engine NO_x emission standards have been reduced by more than 97%, from 6.0g/bhp-hr to 0.20g/bhp-hr (see also **Figure 3**);
- (iv) off-road diesel engine PM emission standards have been reduced by more than 97%, from 0.60g/bhp-hr to 0.015g/bhp-hr; and
- (v) off-road diesel engine NO_x emission standards have been reduced by more than 95%, from approximately 6.9g/bhp-hr (or higher) to 0.30g/bhp-hr.

Figure 2: U.S. EPA PM emissions standards for heavy-duty on-road diesel trucks (t) or urban buses (ub) in grams per brake-horsepower-hour (g/bhp-hr) (left axis) and as % of “unregulated” engine emissions (right axis)²

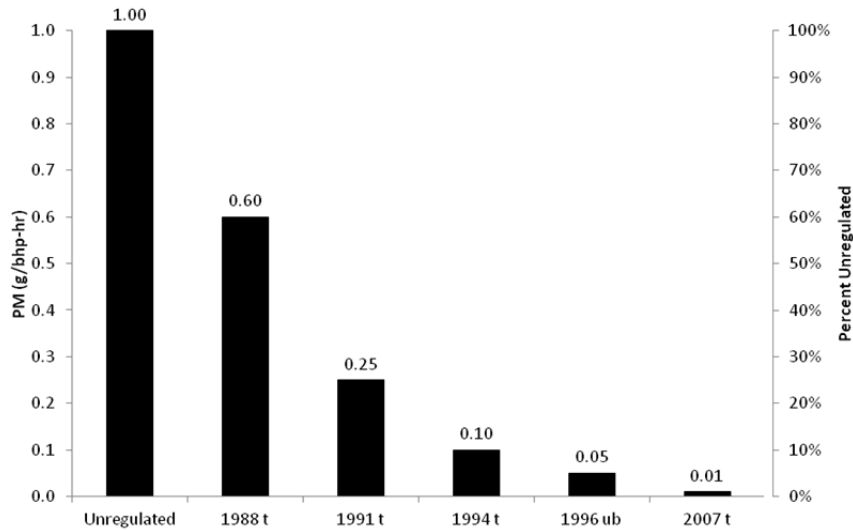
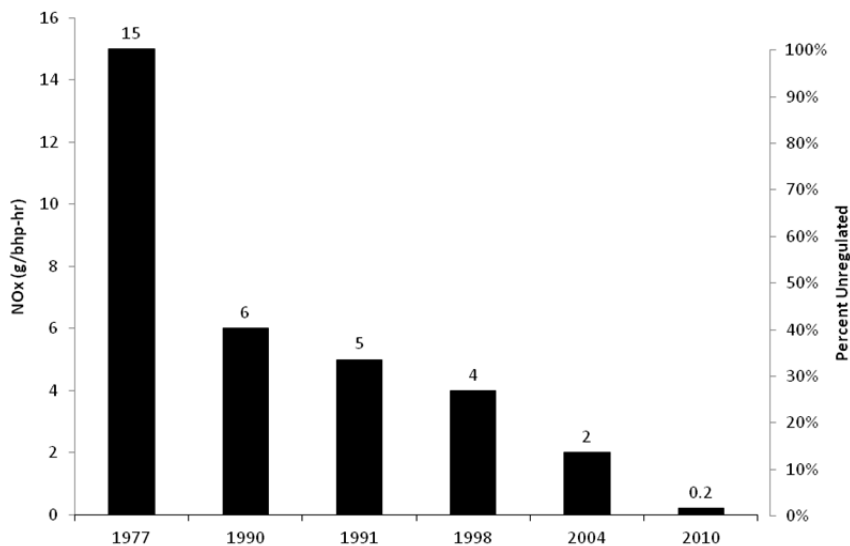

Figure 3: U.S. EPA NOx emission standards for heavy-duty on-road diesel engines in grams per brake horsepower-hour (g/bhp-hour) (left axis) and as a percentage of “unregulated” emissions (right axis).



² For purposes of use of metric units, 1hp = 0.7457kW.

It is noteworthy that diesel engine emission regulations for heavy-duty engines are defined in different units than regulations for passenger vehicles. Regulatory agencies recognize that heavy-duty engines in commercial vehicles, including all of the non-road applications in addition to on-highway vehicles, are “work vehicles”, so the grams per mile (g/mi) or grams per kilometer (g/km) metrics that are used for passenger vehicles are not appropriate units of measure for the emissions from these “work” engines, many of which do their work while stationary or moving slowly, or while carrying extreme loads compared to passenger vehicles. For this reason, emission standards for heavy-duty engine (commercial vehicle) applications are expressed as mass emissions per unit work, either grams per brake-horsepower-hour (g/bhp-hr) or grams per kilowatt-hour (g/kw-hr). Many of the figures and tables in this paper are taken from the heavy-duty engine literature, and so are expressed as units of mass per unit of work. Units of measure notwithstanding, similar emission control technologies on passenger cars will yield similar effects with regard to PM mass and composition as observed on heavy-duty engines. As a result, passenger cars equipped with diesel oxidation catalysts and wall-flow particulate filters and operating on ULSD fuel exhibit exhaust characteristics similar to NTDE, as will be seen in **Section 8.3.6**.

All of the regulations noted in **Table 1**, taken together, resulted in the need for and implementation of fundamental changes and advancements in the design, performance, sophistication and efficiency of diesel engine systems and the fuels upon which they operate in order to meet the regulations. This, in turn, has yielded substantial changes in the concentrations and chemical composition of the exhaust from diesel engines since the last IARC carcinogen hazard classification review was conducted in 1988 (IARC Monograph Vol. 46 (1989)).

As will be described later, TDE is a complex mixture of gases, semi-volatile chemicals and PM with adsorbed and absorbed chemicals. In contrast, NTDE consists largely of gases with extremely low concentrations of PM that is significantly different in composition compared to TDE.

Previous hazard assessment reports expressly noted that diesel engine technology was changing, and that when advances were made it would be appropriate to review the general applicability of the health hazard conclusions based on traditional technology to the newly emerging diesel technologies. IARC specifically recognized that “changes are expected in the future” (IARC (1989)). The EPA Health Assessment Document (US EPA (2002)) stated:

“The health hazard conclusions are based on exhaust emissions from diesel engines built prior to the mid-1990s....” “As new and cleaner diesel engines, together with different diesel

fuels, replace a substantial number of existing engines, the general applicability of the health hazard conclusions will need to be re-evaluated.”

5.0 NEW TECHNOLOGY DIESEL DEVELOPMENTS SINCE THE MID-1980s

5.1 “TRANSITIONAL” DIESEL TECHNOLOGY DEVELOPMENT – 1988 TO 2006

Until the mid-1980s, a wide variety of diesel engine designs and technologies were still available and competing in the marketplace, including two-stroke and four-stroke combustion systems; two-valve and four-valve gas exchange systems (or side ports in the case of two-stroke engines); direct and indirect fuel injection systems; and turbocharged and naturally aspirated air induction systems. All of those various technologies are in the mix of diesel engines that have been the subjects of epidemiological studies of occupational exposures to diesel engine exhaust to date. As time passed however, and as a result of increasingly stringent “technology-forcing” emission standards, less capable engine designs were eliminated and the industry has converged on a common diesel engine architecture: four-stroke combustion, four-valve gas exchange, high pressure direct fuel injection with electronic control, and turbocharged air induction. Other technological changes have ensued (**Figure 4**). Intake air cooling was introduced – first using engine cooling water, then air-to-air heat exchangers, to produce lower peak combustion temperatures to reduce NO_x emissions. In 2002, “cooled exhaust gas recirculation” (Cooled EGR) was introduced for additional NO_x control. This required even higher fuel injection pressures for particulate control and variable geometry and two-stage turbocharging.

Figure 4: Schematic rendering of evolutionary development of advanced diesel technology followed by revolutionary advances occurring with introduction of ULSD fuel and wall flow Diesel Particulate Filters (DPF).

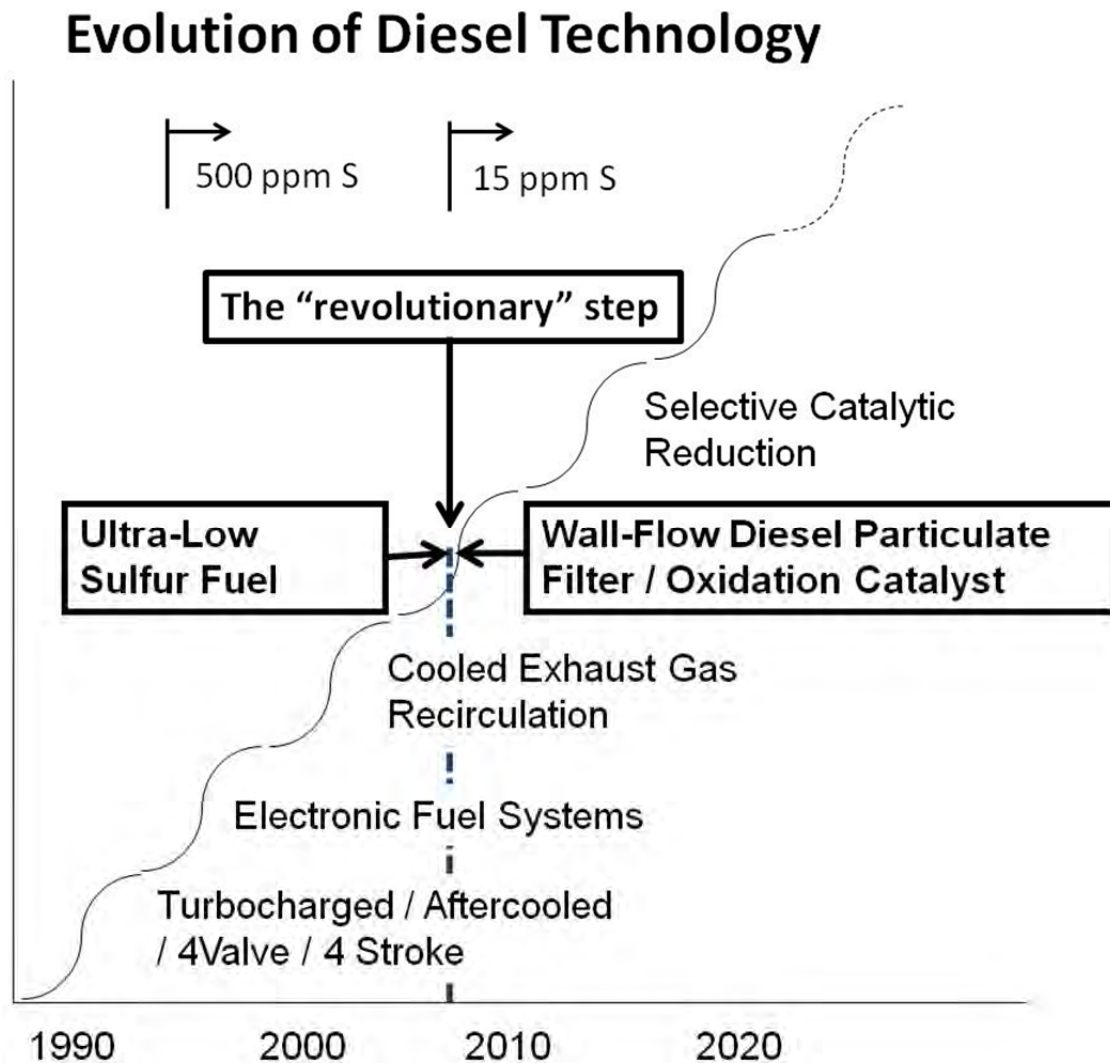

These progressively-improved diesel engine and aftertreatment packages define what is referred to as “transitional diesel engines” and resulted in much lower emissions of NO_x and PM. During this period, fuel technology also changed as fuel sulfur was reduced from up to 5000ppm (0.5%) to 500ppm to enable diesel engines to meet the then-applicable 0.10 g/bhp-hr PM standards and introduce Cooled EGR without unacceptable corrosion due to sulfuric acid. In describing the substantial emissions benefits from those transitional technologies, an HEI-sponsored study of exhaust-derived particulate and gaseous compounds in the Tuscarora Tunnel (Gertler et al. (2002)) concluded: *“Comparing the HD vehicle PM mass emission factors from this study with those obtained in other tunnel studies performed over the past 25 years showed a dramatic decline in the PM emission rate.*

Overall, the HD PM mass emission rate decreased by more than a factor of 6 during this period. Likely reasons for this decrease are improved vehicle technology and fuel.”

The report goes on to note that *“emissions from the HD (heavy duty) fraction of the fleet have decreased faster than emissions from the LD (light duty) fraction of the fleet.”*

5.2 NEW TECHNOLOGY DIESEL ENGINE DEVELOPMENT – 2007 AND BEYOND

Engine emissions regulations changed fundamentally in 2007. The comprehensive regulatory programs enacted in 2001 to reduce diesel emissions to near-zero levels drove a major change in diesel engine emission control technologies for the 2007 model year. What started as evolutionary advances transitioned to revolutionary advances that dramatically reduced and changed the nature of diesel engine emissions.

In 2007, the applicable particulate matter standard, as adopted by U.S. EPA, was reduced by an additional 90% -- from 0.10 to 0.01g/bhp-hr. The 0.01g/bhp-hr particulate standard was not achievable with combustion development alone and required exhaust aftertreatment using wall-flow DPFs and another reduction in fuel sulfur to a maximum of 15ppm S. This was a truly “revolutionary” step in diesel emission control technology that resulted in a significant reduction in PM mass emissions as well as a significant shift in particulate chemistry. Diesel emission control strategies moved from the transitional engine-based designs and specific hardware improvements to fully integrated designs and systems -- systems that encompassed improved diesel fuels with ultra-low sulfur content, improved diesel engine components, catalyzed exhaust after-treatment systems, and electronic sensing and control systems. Subsequently, in 2010, the ultra-low 0.20g/bhp-hr NOx emissions standard led to the integration of NOx aftertreatment systems in the form of Selective Catalytic Reduction (SCR) systems and, in one case, NOx adsorber based systems. (Bauner et al. (2009); Charlton et al. (2010); Colucci (2004); Dollmeyer et al. (2007); Li et al. (2009); Johnson (2010)/(2011); Tschoeke et al. (2010)). Details of these exhaust aftertreatment systems and crankcase ventilation systems are covered in **Appendix 1.**

The fully integrated systems approach of the new technology diesel engines has resulted in more than order-of-magnitude emissions reductions and, in many cases, the reduction of emission constituents to background or detection limits. Significantly, among the emission constituents that have been reduced to near-zero levels are the EC nanoparticles with associated hydrocarbons that were of primary concern at the time of IARC’s evaluation of TDE in 1988 (Khalek et al. (2011); Liu et al. (2008a), (2008b), (2009a), (2009b), (2010)).

The extensive technological advancements that have been developed and implemented over the past two decades through an integrated approach to reduce diesel emissions, have produced the new technology diesel engine. These advancements can be summarized as follows:

- (i) diesel engine control systems are no longer mechanical and are now fully electronic and computerized. This enables very precise, second-by-second management of the fuel injection and combustion processes;
- (ii) fuel-injection pressures and fuel atomization have increased dramatically through the introduction of electronically-controlled high-pressure fuel-injection systems, which promote more complete and clean combustion;
- (iii) diesel AFRs and combustion temperature control systems have advanced to reduce NO_x emissions through sophisticated fuel-injection timing and rate-shaping, variable geometry and two-stage turbocharging, Cooled EGR, and enhanced charge-air cooling systems;
- (iv) diesel oxidation catalysts (DOC) have advanced to the point where they can reduce hydrocarbons and other organic emission species by 90% or more under a broad range of operating conditions;
- (v) filters or coalescers have been installed in crankcase ventilation systems to reduce significantly the particulate matter emissions from crankcase gases; and
- (vi) the introduction of ULSD fuels, defined in the US as having less than 15ppm S (Europe requires less than 10ppm S), has allowed for the deployment of wall-flow DPFs and the use of more aggressive DOCs which have fundamentally changed the composition of diesel particulates while reducing their emissions to levels that are often below the limits of detection.

Taken together, these engine system components and the use of ULSD have resulted in new technology diesel engines. As described later, the resultant New Technology Diesel Exhaust (NTDE) is fundamentally different, both quantitatively and qualitatively, from the unregulated Traditional Diesel Exhaust (TDE) that was the subject of the 1988 IARC evaluation.

6.0 CARCINOGENIC HAZARD EVALUATIONS: SPECIFIC CHEMICALS VERSUS COMPLEX MIXTURES FROM EVOLVING TECHNOLOGIES

The majority of IARC evaluations (IARC (2012a), (2012b)), excluding biological agents, can be placed in two categories: (a) specific chemicals, or (b) exposures to emissions from a specific technology. The two kinds of evaluations have some significant differences. A chemical, such as benzene or formaldehyde, is the same chemical today as it was a decade or a century ago. The uses of the chemical may change over time, but its basic chemical properties do not change. Nonetheless, knowledge of the carcinogenic hazard may change over time as a result of additional research and advances in scientific knowledge. Knowledge of human exposure also may change as a result of new measurements and changes in work place practices, including control of exposure to the specific agent. Indeed, work place practices are often influenced by previous IARC classifications of the carcinogenic hazard of a specific chemical.

The situation for a complex technology-specific agent such as diesel engine exhaust, gasoline engine exhaust, or man-made products such as glass wool fibers, is very different than that for a specific chemical. The physical properties of these complex agents may be purposefully and significantly changed over time with technological advances, including advancements made to reduce the hazardous properties of the agent. As discussed later, the concentrations of PM in TDE have been steadily reduced as transitional diesel engine technology and low- and ultralow sulfur fuels have been introduced. However, those evolutionary reductions pale in comparison with the recent revolutionary reductions in concentrations and changes in the composition of NTDE as compared to TDE.

It is important to acknowledge the beneficial effects that improving diesel engine technologies have had on diesel particulate emissions, including implications regarding carcinogenicity, so as not to undermine the continued introduction and adoption of advanced diesel emission control technologies around the world, especially in developing countries and emerging markets.

7.0 ADVANCED COLLABORATIVE EMISSIONS STUDY (ACES) OF NTDE

While specific analysis of health effects studies is left to other papers, it is important to note briefly a new collaborative study that is underway, since it involves a comprehensive characterization of the emissions from new technology diesel engines that are compliant with U.S. EPA's 2007 emission standards.

As new diesel technology began to be developed by individual engine companies in response to increasingly stringent emission-control regulations, it became apparent that broad acceptance of the new technology would be enhanced by a complementary collaborative effort that focused on a detailed characterization of engine emissions and potential health impacts. Ultimately, with strong support from industry, what has become known as the 'Advanced Collaborative Emissions Study' (ACES) emerged. ACES is a cooperative, multi-stakeholder effort coordinated by two internationally recognized science-based and non-profit organizations -- the Health Effects Institute (HEI), and the Coordinating Research Council (CRC). The overall effort has been stewarded by an ACES Steering Committee, which advises HEI and CRC. This Steering Committee includes representatives of the U.S. EPA, U.S. Department of Energy (DOE), California Air Resources Board (CARB), American Petroleum Institute (API), National Resources Defense Council (NRDC), National Institutes of Occupational Safety and Health (NIOSH), engine manufacturers, emission control manufacturers, the petroleum industry, and others. Most importantly, ACES has been guided by an independent Oversight Committee comprised primarily of academic scientists.

The organization, management and funding of ACES are described in the Preface to one of the initial HEI reports on the program (Mauderly et al. (2012)). That document summarizes the three phases of the ACES program. Phase 1 is most relevant to this paper:

"Phase 1: Extensive emissions characterization of four production-ready heavy-duty diesel (HHDD, i.e. gross vehicle weight larger than 33,000 lbs) engines and control systems designed to meet the 2007 standards for reduced PM. This phase was conducted at Southwest Research Institute (SwRI) in 2007 and 2008 and was the basis for selecting one HHDD engine/after-treatment system for health testing in Phase 3."

A research team, under the leadership of Imad Khalek at SwRI was selected to carry out the Phase 1 engine emission characterization activities under contract to CRC. A description of the characterization effort is found in Khalek et al. (2011) with additional details contained in Khalek et al. (2009), the extensive report on the ACES Phase 1 effort issued by the CRC.

Four different engine manufacturers provided 2007 model year production engines for the characterization studies conducted at SwRI. All four engines were from product lines developed to meet the U.S. EPA's stringent 2007 emissions standards including PM at 0.01g/bhp-hr and NOx at 1.20g/bhp-hr. The specific engines tested were a Caterpillar C13 (430 hp), a Cummins ISX (455 hp), a Detroit Diesel Corporation Series 60 (455 hp), and a Mack MP7 (395 hp) manufactured by Volvo.

From the start of Phase 1, it was agreed that the Phase 3B health studies would involve exposures to diluted exhaust for 16 hr/day, 5 days/week for up to 30 months. Further, it was understood that it would be important to have the engine operating under a rigorous variable-load duty cycle. This led to a decision to create a 16-hour engine test cycle that would also be used in the emissions characterization studies at SwRI. This allowed for a direct link between the Phase 1 emissions characterization effort and the use of the engines and the same test cycle at the animal toxicology facility that would conduct the health studies. The details of that test cycle and its development are described in Clark et al. (2007).

The 16-hour ACES cycle includes four 4-hour segments consisting of US Federal Test Procedure (FTP) segments mixed with segments of the CARB 5-Modes driving cycles. The ACES cycle was designed to represent modern truck usage and included a wide range of engine loads and speeds reflecting both urban and rural (highway) driving. The 16-hour cycle also added useful information on emissions during particle filter regeneration, which may not occur during shorter test cycles. Regeneration typically occurs once or twice during each integrated 16-hour cycle. The Phase 1 engine exhaust characterization research was conducted with engines using ULSD fuel meeting U.S. fuel standards for 2007 and beyond. Specifically, the ACES fuel contained 4.5ppm S, 26.7 vol% aromatics, carbon content of 86.32 wt%, hydrogen content of 12.92 wt%, oxygen content (by difference) of 0.76 wt%, density of 855.6g/l, API gravity at 60°F of 33.8, density at 15°C of 855.6g/l, and a cetane number of 47.5.

Emissions data obtained from the four engines over the ACES test cycle will be detailed later to demonstrate the significant differences in PM mass and chemical composition between NTDE and TDE.

8.0 QUANTITATIVE AND QUALITATIVE DIFFERENCES BETWEEN NTDE AND TDE

In the following sections, qualitative and quantitative differences in the physical and chemical characteristics of NTDE and TDE are reviewed. For each characteristic, the assessment that IARC made of that characteristic in the 1989 Monograph as it pertained to TDE is also described. Some of the exhaust characteristics and parameters reviewed below were not discussed in the IARC Monograph, but have been raised by investigators subsequent to the 1988 review as being important to the potential association of TDE with health effects. The discussion of TDE is followed by a presentation of the detailed findings relating to NTDE.

8.1. TRADITIONAL DIESEL EXHAUST (TDE) PM

8.1.1 General Characteristics of TDE PM

In the earlier IARC Monograph Vol. 46 (1989), TDE was characterized as having a significantly higher concentration of particulate matter than the exhaust from gasoline-fueled vehicles, and that, in general, heavy-duty diesel trucks emitted up to 40 times more particulate than catalyst-equipped gasoline-fueled vehicles. IARC estimated that the composition of the particles was approximately 80 percent elemental carbon.

In a later analysis, the California Air Resources Board (CARB (1998a), (1998b), (1998c), (1998d)) estimated that some light-duty diesel engines could emit 50 to 80 times, and some heavy-duty diesel engines 100 to 200 times more particulate mass than typical 3-way catalyst-equipped gasoline engines. CARB similarly estimated that the amount of elemental carbon (EC) in the average diesel particle typically ranged up to 71 percent. CARB indicated that TDE particles were comprised (by weight) of carbon (88.3%), oxygen (4.9%), hydrogen (2.6%), sulfur (2.5%), metals (1.2%), and nitrogen (0.5%). The fundamental premise was that the particles contained in TDE were mainly aggregates of spherical elemental carbon (EC) particles coated with organic and inorganic substances. It was also assumed that the inorganic fraction consisted of small solid carbon particles, ranging from 0.01 to 0.08 micrometers in size, along with sulfur, oxygen, hydrocarbons, sulfate (SO₄), CO, and NO_x.

The Diesel Health Assessment Document (HAD), prepared by the U.S. EPA (US EPA (2002)), reached conclusions similar to those of IARC and CARB regarding the characteristics and composition of TDE. More specifically, the document noted that TDE particles are “*primary spherical particles consisting of solid carbonaceous (EC) material and ash (trace metals and other elements),*” absorbed onto which “*are added organic and sulfur*

compounds (sulfate) combined with other condensed material' (recall **Figure 1**). The U.S. EPA concluded that the diesel exhaust particles were typically composed of 75% EC (ranging up to 90%), 20% organic carbon (OC) (ranging down to 7%), and small amounts of sulfate, nitrate, trace elements, water, and unidentified compounds.

The earlier IARC Monograph Vol. 46 (1989) included a table that summarized emission data on various diesel and gasoline engines (1980-1985 era) operated on the US Federal Test Procedure (FTP) cycle. The total particulate phase emissions for a heavy-duty diesel vehicle, a light-duty diesel vehicle, a gasoline vehicle without a catalytic converter, and a gasoline vehicle with a catalytic converter were: 1036, 246, 62 and 11 mg/km, respectively. The diesel engines of that era operating on high sulfur content fuel can be viewed as producing TDE. The gasoline vehicle operated without a catalytic converter can be viewed as producing traditional gasoline exhaust (TGE) and the gasoline vehicle operated with a catalytic converter can be viewed as producing modern gasoline exhaust (MGE). However, it should be emphasized that gasoline engine and gasoline fuel technology also continued to evolve post-1980s (Colucci (2004)).

In the sections that follow on the characterization of NTDE, comparisons are made to TDE where data are available. In addition, to provide added perspective, some comparisons are made to emissions from modern gasoline and compressed natural gas (CNG) vehicles. The comparisons to modern gasoline-fueled vehicles are relevant to the forthcoming IARC review which will evaluate both gasoline engine exhaust and diesel engine exhaust regarding their human carcinogenic hazard classification.

8.1.2 Effects of Engine Operating Conditions and Duty Cycle on TDE PM Composition

“Diesel exhaust particulate” is generally defined in any experiment as “whatever material gets collected on filters used to sample the exhaust.” It is collected, weighed and analyzed by various means. Thus, the material identified as diesel particulate is affected by engine design and operation, by fuel chemical composition, and by exhaust handling and sampling procedures, including dilution ratio, sampling temperatures, exhaust filter material, and even by ambient conditions.

Engine operating conditions, or duty cycles, also have a important effect on the composition of TDE PM emissions. Advanced emission control technologies have mitigated this effect, but it was quite significant for “unregulated” engines. The data of Wall and Hoekman (1984) illustrate this effect for unregulated engines typical of the early 1980s. **Figure 5** illustrates the

variation in the emission rates of five PAH compounds over three operating conditions: 'idle', 'cruise', and 'high power'.

Figure 5: Impact of engine operating condition on TDE PAH emissions (appears as Figure 22 in Wall and Hoekman (1984))

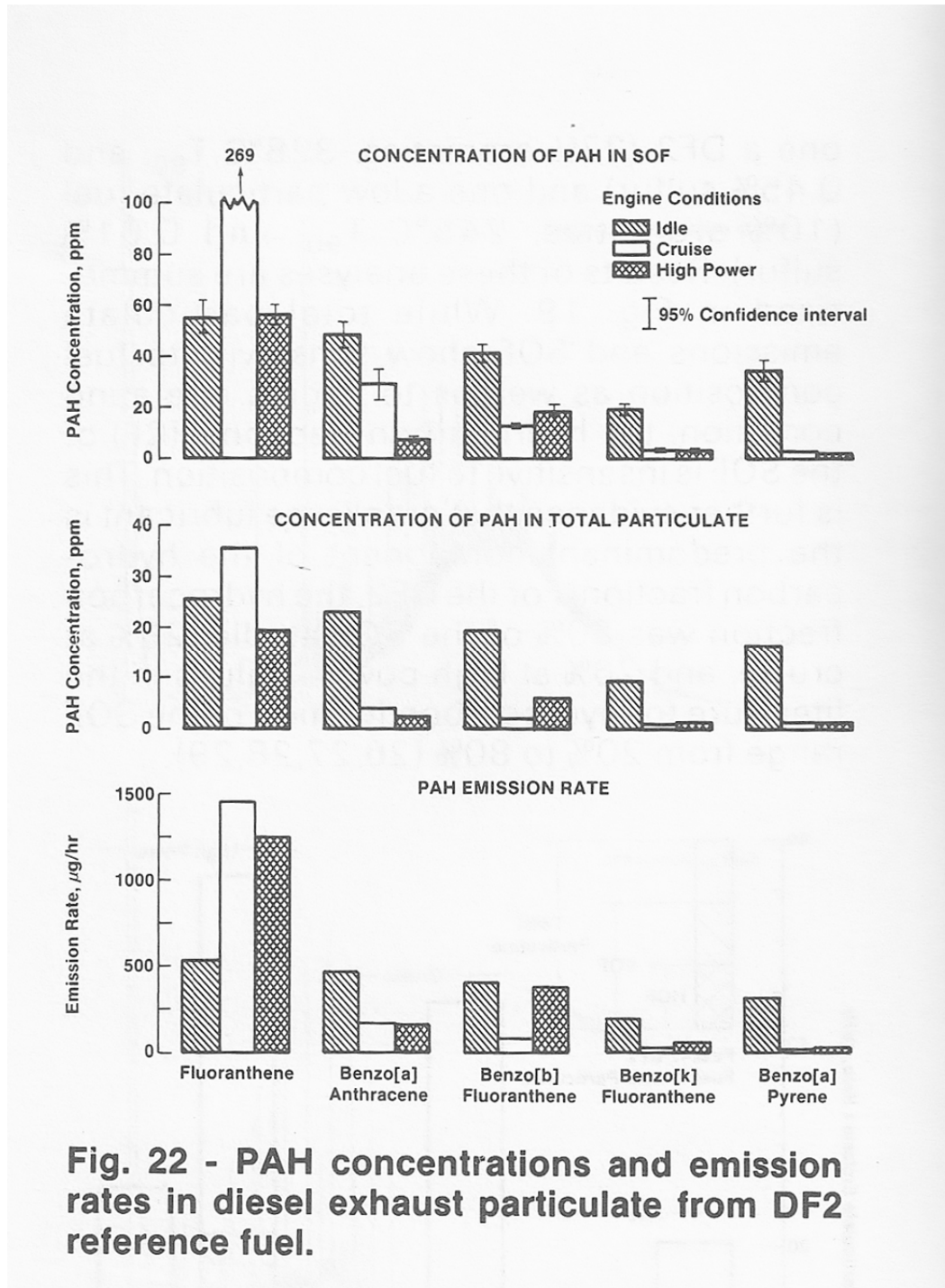

Fig. 22 - PAH concentrations and emission rates in diesel exhaust particulate from DF2 reference fuel.

Figure 6: Impact of engine duty cycle on NO_x and PM emissions (appears as Figure 26 in Clark et al. (2006))

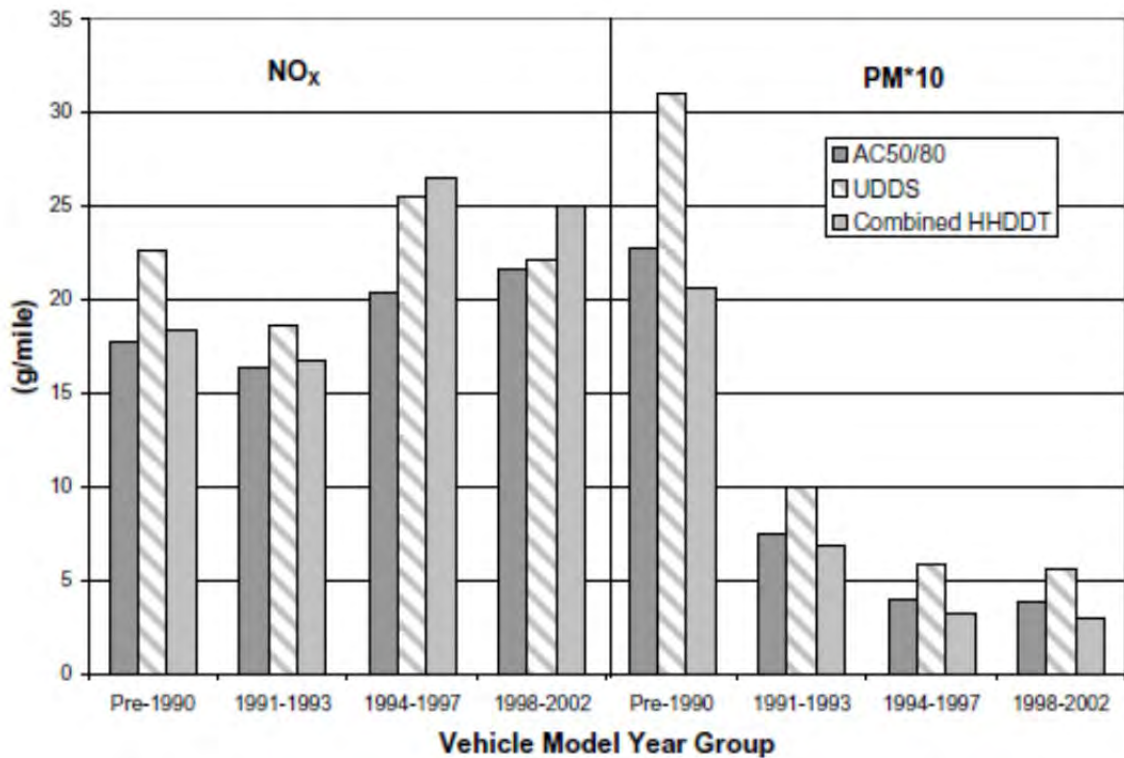
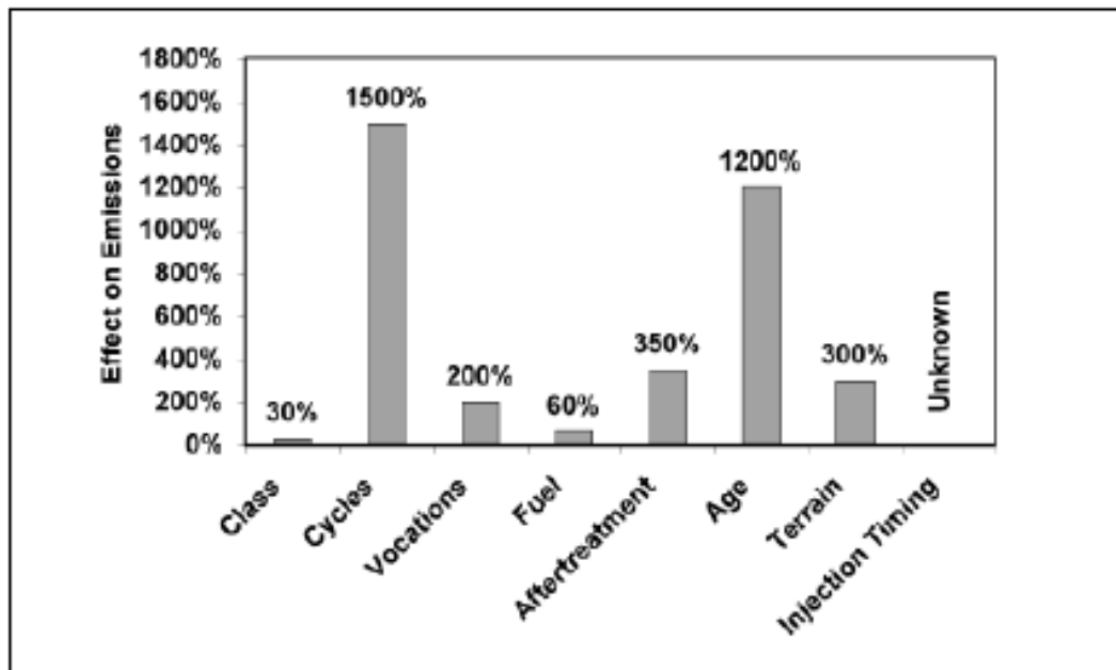

Figure 26: Comparison of the AC50/80, UDDS, and the combined HHDDT for NO_x and PM emissions.

The effect of duty cycle and load on the composition of NO_x and PM emissions can also be seen in **Figure 6** (Clark et al. (2006)). Clark et al. (2002) compared the relative effects of vehicle class and weight, emission measurement cycle, vehicle vocation (application) and driving activity, fuel, aftertreatment (catalytic converter), age (level of technology) and terrain on PM emissions (**Figure 7**), and showed PM emissions varying by 1500% due to duty cycle differences alone.

Figure 7: Relative impact of operating variables on PM emissions (appears as Figure 6 in Clark et al. (2002))



The wide variation in emissions documented in these reports indicate that it is absolutely critical to understand and account for the effects of engine duty cycle and other operating factors when interpreting or extrapolating the results from any *in vitro* and *in vivo* studies of diesel exhaust exposure. In this regard, it is noteworthy in **Figure 6** that advancing diesel engine technology during the “transitional period” from pre-1990 to 2002 reduced PM emissions by an order of magnitude across all duty cycles.

Additional effects of emissions sampling systems, as well as testing conditions and other factors, are discussed in detail in **Appendix 2**. Nitroarene artifacts, which also are significant in some studies, are discussed in **Appendix 3**.

These effects of engine operation and duty cycle on the composition of emissions greatly increase the difficulty of correlating exposure data from specific diesel engine applications and duty cycles to broad-based TDE exposures of the general population, for which ambient diesel particulate is generated from a wide range of engine technologies operating over widely varying duty cycles and ambient conditions. As a result, direct sampling of diesel particulate in exposure studies is to be preferred. However, when this is not possible, researchers search for surrogates or markers for diesel particulate, as discussed in **Section 9**.

In contrast to the foregoing discussion, new technology diesel engines, utilizing DOCs and DPFs, are effective over the entire engine operating range, so that the reduction in all chemical compounds associated with PM emissions are significantly lower regardless of engine duty cycle and operating condition. Furthermore, variation across the operating range is also reduced. The most significant operating effect for new technology diesel engines is when the particulate filter is regenerated, which still produces emissions well below TDE thresholds, as noted elsewhere in this paper. Thus, the wide variation in chemical composition of diesel PM that is seen for TDE is not observed for NTDE.

8.2 NTDE EMISSIONS ARE SIGNIFICANTLY LOWER THAN TDE EMISSIONS

The results of the detailed ACES characterization study of four engines (compliant with the 2007-EPA emission standards) by Khalek et al. (2011) show that the PM emissions as well as the other three U.S. regulated emissions (CO, NMHC, and NO_x) were well below the applicable 2007 standards and remarkably lower than the 1998 standard (**Table 2**) (Khalek et al. (2011)).

Table 2: Average Regulated Emissions Summary for Four FTP Composite Cycles 1/7* cold-start + 6/7* hot-start), One per ACES Phase 1 2007 Engine (Khalek et al. (2011))

	1998 EPA Standard (g/bhp-hr)	2007 EPA Standard (g/bhp-hr)	2007 Average Emissions (g/bhp-hr)	% Reduction Relative to 2007 Standard	% Reduction Relative to 1998 Standard
PM	0.1	0.01	0.0014±0.0007	86	99
CO	15.5	15.5	0.48±0.33	97	97
NMHC ^e	1.3 ^a	0.14	0.015±0.024	89	97 ^d
NO _x	4.0 ^b	1.2 ^c	1.09±0.15	9	73

^a EPA limit was based on total hydrocarbon including methane

^b EPA limit went to 2.4 g/hp-hr in 2004

^c Average value between 2007 and 2009, with full enforcement in 2010 at 0.20 g/hp-hr

^d Value is calculated based on Avg. THC value of 0.034 g/hp-hr using the ACES Phase 1 data

^e NMHC is reported as the difference between measured THC and methane

Specifically, the PM emissions amounted to an 86% reduction relative to the 2007 standard and a 99% reduction relative to the 1998 standard (recall **Figure 2**). The CARB study by Herner et al. (2009) clearly demonstrated the reduction in PM mass emissions relative to TDE (**Figure 8**).

Figure 8: PM emissions for one TDE vehicle and six NTDE vehicles configured with DPFs and SCR systems (data from Herner et al. 2009). Expressed as mg/km on left and as percent of TDE on right. The number at the top of each bar is the PM emissions in mg/mile.

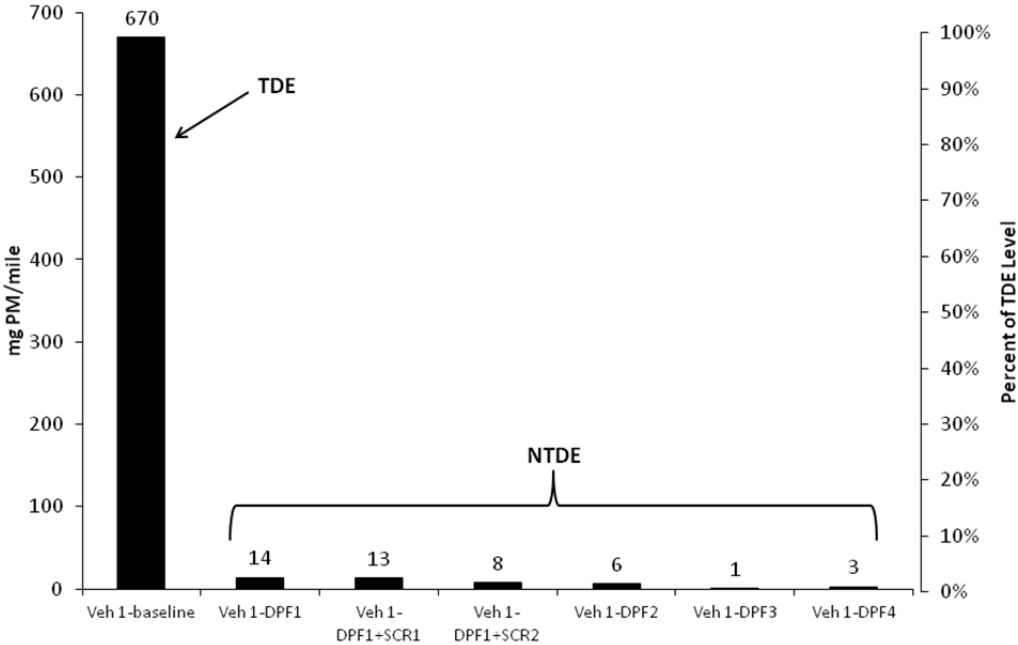

In fact, the PM emission levels from new technology heavy-duty diesel engines have been reduced to levels comparable to current CNG and gasoline fueled engines. The evolution in both CNG and diesel engine emissions can be seen in **Figure 9**, as presented to CARB by Wall (Wall (2012)). It is notable that 2012 NTDE and the exhaust emissions from a 2012 CNG engine are practically indistinguishable from each other and from 2012 gasoline engine certification data as well.

Figure 9: Cummins diesel and natural gas engines and other manufacturers' gasoline engines emissions over US Federal Certification Test cycle. (Wall (2012))

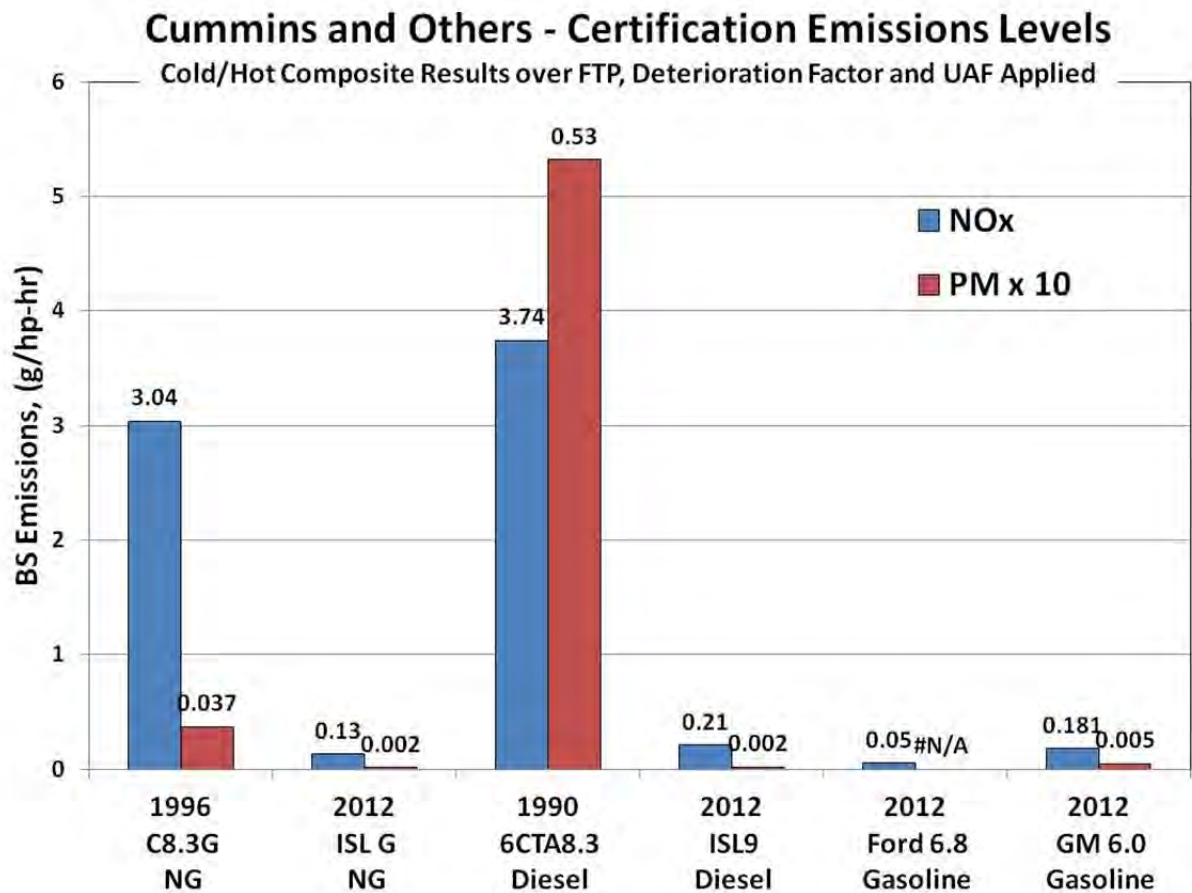

As reviewed in Hesterberg et al. (2011), multiple recent studies of the emissions (in g/mile) from heavy-duty transit buses operated with diesel particulate filters have shown that NTDE PM mass emissions are not “significantly higher” than observed for other technologies, but are similar to the PM emission levels from low-emission CNG-fueled vehicles (Ayala et al. (2002); Ayala et al. (2003); Gautam et al. (2005); Lanni et al. (2003); LeTavec et al. (2002); McCormick et al. (1999); Northeast et al. (2000); Norton et al. (1999); Wang et al. (1997)) (Figure 10).

Figure 10: PM mass emissions for transit buses fuelled with ULSD (NTDE) or compressed natural gas (CNG) and operated with or without a DOC. Emissions in mg/mile on the left and as % of TDE on the right. (data from Hesterberg et al. (2008)).

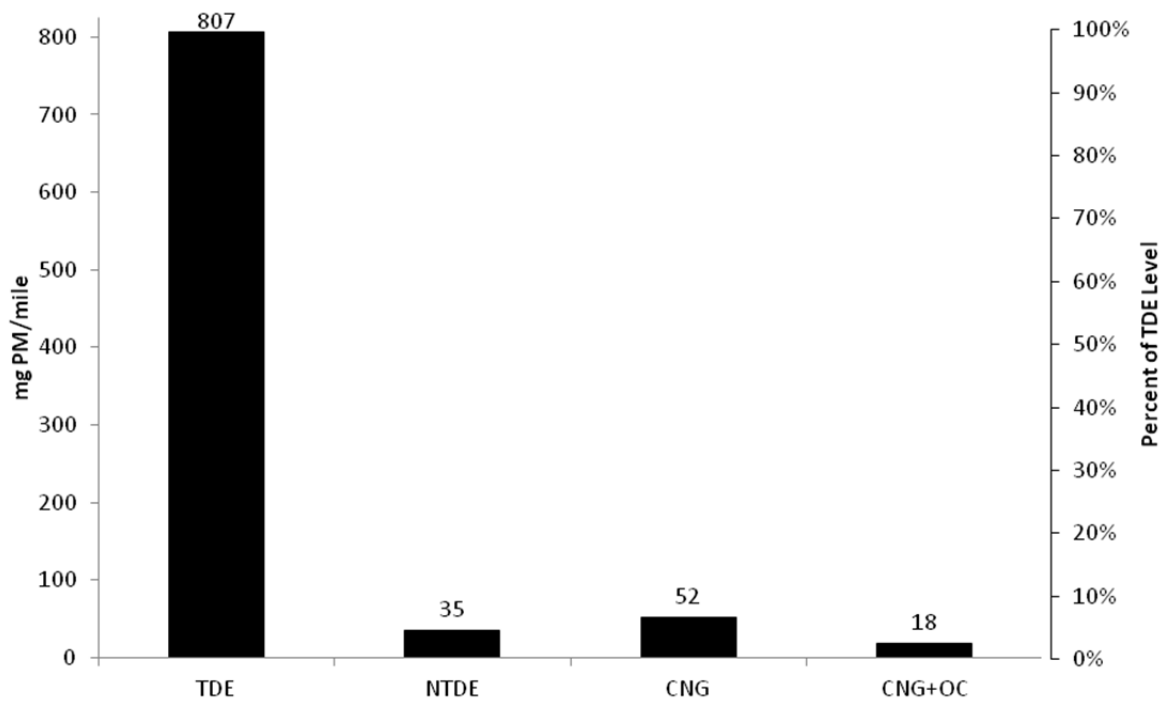

In summary, data developed since 1989 clearly show that the PM emissions rates from NTDE are substantially lower than those for TDE and are directly comparable to the emission levels from modern low-emission gasoline-fueled TWC-equipped engines and CNG-fueled engines. Thus, PM emissions, which were the primary concern for TDE and the focus of IARC’s 1989 evaluation of diesel engine exhaust, have been reduced to near-zero levels in NTDE.

8.3 NTDE PM HAS A SIGNIFICANTLY DIFFERENT COMPOSITION THAN TDE PM

8.3.1 Significant Reduction of Elemental Carbon and Dominance of Sulfate in NTDE PM

On a percentage basis, PM in TDE is primarily EC (i.e., up to 80%). In contrast, the PM in NTDE, as evaluated in the ACES program, contains only about 10% of the remaining small PM mass as EC (**Table 3**, Khalek et al. (2011); Liu (2009a)). Importantly, PM mass in NTDE is typically reduced by 99+% below the level of the 1998 standards (**Table 2**) and 99.9% below unregulated levels. Thus, the soot or EC core fraction of NTDE (recall **Figure 1**) has

been reduced by four orders of magnitude relative to TDE, from approximately 800mg/bhp-hr to approximately 200µg/bhp-hr (Table 3, Table 4).

Table 3: Summary of average unregulated emissions for all twelve repeats of the 16-hour cycles for all four 2007 ACES Engines and for 2004 Technology Engines used in CRC studies E-55/E-59 (dioxins were compared to 1998 levels) (Khalek et al. (2011))

	2004 Engines Avg. ± stdev., mg/hr	2007Engines ^a Avg. ± stdev., mg/hp-hr	2007 Engines Avg. ± stdev., mg/hr	Avg. % Reduction Relative to 2004 Technology Engines
Single Ring Aromatics	405.0±148.5	0.76±0.35	71.6±32.97	82%
PAH	325.0±106.1	0.74±0.25	69.7±23.55	79%
Alkanes	1030.0±240.4	1.64±0.83	154.5±78.19	85%
Hopanenes	8.2±6.9	0.0011±0.0013	0.1±0.12	99%
Alcohols and Organic Acids	555.0±134.4	1.14±0.27	107.4±25.4	81%
Nitro-PAH	0.3±0.0	0.0065±0.0028	0.1±0.0	81%
Carbonyls	12500.0±3535.5	2.68±1.00	255.3±95.2	98%
Inorganic Ions	320.0±155.6	0.98±0.40	92.3±37.7	71%
Metals and Elements	400.0±141.4	0.071±0.032	6.7±3.0	98%
OC	1180.0±70.7	0.56±0.50	52.8±47.1	96%
EC	3445.0±1110.2	0.24±0.05	22.6±4.7	99%
Dioxins/Furans	N/A	6.6E-07±5.5E-07	6.2E-05±5.2E-05	99% ^b

^a Data shown in brake-specific emissions for completeness. No comparable brake-specific emissions data were available

^b Relative to 1998 technology engines

Table 4: Organic species emissions comparison from a 2004 HD diesel engine (308.5ppm S diesel fuel) without after-treatment and a 2007 HD diesel engine (9.2ppm S diesel fuel) equipped with a catalyzed DPF system (Liu et al. (2010))

Compound (carbon number)	2004 Engine ^a		2007 Engine ^a		% reduced
Elemental Carbon	49700	± 3550	150	± 38.2	99.7±7.2
Organic Carbon	37800	± 4360	213	± 101	99.4±11.8
Organic Mass	45300	± 5230	256	± 121	99.4±11.8
n-Alkanes					
n-undecane (11)	< 0.01	± 2.97	1.04	± 1.76	--
n-dodecane (12)	<0.01	± 0.795	0.279	± 0.286	--
n-tridecane (13)	2.25	± 0.859	<0.01	± 0.186	>99.6 ± 46.4
n-tetradecane (14)	10.4	± 2.64	<0.01	± 0.203	>99.9 ± 27.3
n-pentadecane (15)	34.4	± 5.52	<0.01	± 0.00	>99.9 ± 16.0
n-hexadecane (16)	84.6	± 13.4	<0.01	± 0.00	>99.9 ± 15.8
n-heptadecane (17)	96.5	± 10.7	<0.01	± 0.193	>99.9 ± 11.3
n-octadecane (18)	68.8	± 12.7	<0.01	± 0.413	>99.9 ± 19.1

n-nonadecane (19)	52.3	±	10.0	<0.01	±	1.02	>99.9 ± 21.1
n-eicosane (20)	75.0	±	7.46	<0.01	±	0.931	>99.9 ± 11.2
n-heneicosane (21)	68.5	±	4.88	<0.01	±	0.348	>99.9 ± 7.6
n-docosane (22)	48.1	±	4.63	<0.01	±	0.423	>99.9 ± 10.5
n-tricosane (23)	19.3	±	8.48	<0.01	±	0.00	>99.9 ± 43.9
n-tetracosane (24)	0.0127	±	2.37	<0.01	±	1.07	--
Branched Alkanes							
norpristane (18)	215	±	34.6	<0.01	±	0.754	>99.9 ± 16.4
pristane (19)	89.4	±	14.6	<0.01	±	0.0725	>99.9 ± 16.4
phytane (20)	28.3	±	9.02	<0.01	±	0.768	>99.9 ± 34.6
Saturated Cycloalkanes							
dodecylcyclohexane (18)	4.26	±	2.67	<0.01	±	0.00	>99.8 ± 62.7
pentadecylcyclohexane (21)	8.92	±	1.91	<0.01	±	0.00	>99.9 ± 21.4
hexadecylcyclohexane (22)	3.52	±	1.85	<0.01	±	0.00	>99.7 ± 52.6
heptadecylcyclohexane (23)	3.53	±	1.05	<0.01	±	0.00	>99.7 ± 29.7
octadecylcyclohexane (24)	1.02	±	1.02	<0.01	±	0.00	>99.0 ± 100
nonadecylcyclohexane (25)	0.896	±	0.451	<0.01	±	0.00	>98.9 ± 50.3
Aromatics							
Biphenyl (12)	140	±	11.4	47.7	±	14.2	65.9 ± 18.3
2-methylbiphenyl (13)	13.3	±	2.09	54.3	±	28.6	--
3-methylbiphenyl (13)	288	±	29.5	152	±	64.0	47.2 ± 32.5
4-methylbiphenyl (13)	62.5	±	5.52	18.8	±	5.10	69.9 ± 17.0
PAHs, POM, and Derivatives							
naphthalene (10)	719	±	79.6	122	±	129	83.0 ± 29.0
2-methylnaphthalene (11)	1290	±	144	82.7	±	52.1	93.6 ± 15.2
1-methylnaphthalene (11)	543	±	52.5	46.1	±	26.1	91.5 ± 14.5
dimethylnaphthalenes (12)	1460	±	113	89.0	±	18.6	93.9 ± 9.0
trimethylnaphthalenes (13)	935	±	45.9	38.8	±	3.95	95.9 ± 5.3
1-ethyl-2-methylnaphthalene	115	±	14.1	4.25	±	1.18	96.3 ± 13.3
2-ethyl-1-methylnaphthalene	6.83	±	1.59	0.673	±	0.193	90.1 ± 26.1
anthracene (14)	7.38	±	1.00	0.862	±	0.385	88.3 ± 18.8
Phenanthrene (14)	78.6	±	11.3	12.3	±	3.62	84.4 ± 19.0
methylphenanthrenes (15)	85.4	±	9.49	3.30	±	0.460	96.1 ± 11.7
dimethylphenanthrenes (16)	66.9	±	5.33	1.17	±	0.239	98.3 ± 8.3
fluorene (13)	131	±	20.6	12.9	±	3.54	90.2 ± 18.4
methylfluorenes (14)	0.00	±	0.00	10.9	±	3.91	--
fluoranthene (16)	4.31	±	0.137	1.13	±	0.564	73.8 ± 16.3
pyrene (16)	11.7	±	1.20	0.979	±	0.649	91.6 ± 15.8
acenaphthalene (12)	30.5	±	1.88	2.18	±	1.42	92.9 ± 10.8
Acenaphthene (12)	45.5	±	6.55	22.0	±	21.1	51.6 ± 60.8
Chrysene + triphenylene (18)	1.05	±	0.133	0.123	±	0.109	88.3 ± 23.0
benz[a]anthracene (18)	0.586	±	0.0579	0.0632	±	0.0698	89.2 ± 21.8
benzo[g,h,i]fluoranthene (18)	0.607	±	0.593	0.258	±	0.270	57.5 ± 142
benzo[b+k+j]fluoranthene (20)	0.240	±	0.0735	0.00776	±	0.00715	96.8 ± 33.6
benzo[a]pyrene (20)	0.0797	±	0.0378	0.00613	±	0.00469	92.3 ± 53.3
benzo[e]pyrene (20)	0.232	±	0.0575	0.00374	±	0.0983	98.4 ± 67.2
benzo[g,h,i]perylene (22)	0.0724	±	0.0240	0.0168	±	0.00885	76.8 ± 45.4
Nitro-PAHs							
1-nitronaphthalene (10)	0.361	±	0.0701	0.0858	±	0.0198	76.2 ± 24.9
2-nitronaphthalene (10)	0.531	±	0.0896	0.0478	±	0.00914	91.0 ± 18.6

methylnitronaphthalenes (11)	0.719	±	0.110	0.0232	±	0.00393	96.8 ± 15.8
2-nitrobiphenyl (12)	0.0228	±	0.00974	0.00166	±	0.00087	92.7 ± 46.5
4-nitrobiphenyl (12)	0.0103	±	0.00644	0.000117	±	0.00009	98.9 ± 63.4
1-nitropyrene (16)	0.0550	±	0.0154	<0.00025	±	0.00	99.5 ± 28.0
9-nitroanthracene (14)	0.192	±	0.00914	0.0403	±	0.00931	79.0 ± 9.6
Oxy-PAHs							
acenaphthenequinone (12)	29.1	±	2.68	0.945	±	1.49	96.8 ± 14.3
9-fluorenone (13)	13.9	±	2.29	6.54	±	1.59	52.9 ± 27.9
Xanthone (13)	8.75	±	3.94	0.386	±	0.0908	95.6 ± 46.1
perinaphthanone (13)	29.7	±	4.33	1.01	±	0.288	96.6 ± 15.5
anthraquinone (14)	5.16	±	0.886	1.30	±	0.506	74.8 ± 27.0
9-anthraaldehyde (15)	1.56	±	0.829	0.0388	±	0.0291	97.5 ± 55.0
Benzanthrone (17)	1.89	±	0.109	0.0154	±	0.00973	99.2 ± 6.3
Aliphatic Aldehydes							
Formaldehyde (1)	5160	±	2440	<0.01	±	58.1	>99.9 ± 48.4
acetaldehyde (2)	1480	±	783	<0.01	±	43.1	>99.9 ± 55.8
Hopanes							
17 α (H)-22,29,30-trisnorhopane (27)	0.430		0.0658	<0.01		0.00	97.7 ± 15.3
17 α (H),21 β (H)-hopane (30)	1.67		0.0558	0.0109		0.0109	99.3 ± 4.0
22S-17 α (H),21 β (H)-29-homohopane (31)	0.925		0.0309	<0.01		0.00	98.9 ± 3.3
22R-17 α (H),21 β (H)-29-homohopane (31)	0.545		0.284	<0.01		0.00	98.2 ± 52.1
22S-17 α (H),21 β (H)-29,30-bishomohopane (32)	2.11		1.60	<0.01		0.00	99.5 ± 75.8
22R-17 α (H),21 β (H)-29,30-bishomohopane (32)	0.288		0.144	<0.01		0.00	96.5 ± 50.0
22R-17 α (H),21 β (H)-29,30,31-trishomohopane (33)	5.33		5.33	<0.01		0.00	--
Steranes							
20S-5 α (H),14 α (H),17 α (H)-cholestane (27)	5.89		4.87	<0.01		0.00	99.8 ± 82.7
20R-5 α (H),14 β (H),17 β (H)-cholestane (27)	0.576		0.0438	<0.01		0.00	98.3 ± 7.6
20S-5 α (H),14 β (H),17 β (H)-cholestane (27)	0.749		0.0729	<0.01		0.00	98.7 ± 9.7

^a Values are reported in $\mu\text{g}/(\text{bhp-h})$, uncertainty is given as the standard error of the test results.

This redistribution of composition in chemical composition is illustrated in **Figure 11** (data from Liu (2009a)) and further confirmed by Biswas et al. (2009) and Kittelson et al. (2006b).

Figure 11: More than 99% PM reduction with DPF and a substantial shift in chemical composition. EC is substantially reduced in NTDE and sulfate dominates. (data from Liu (2009a))

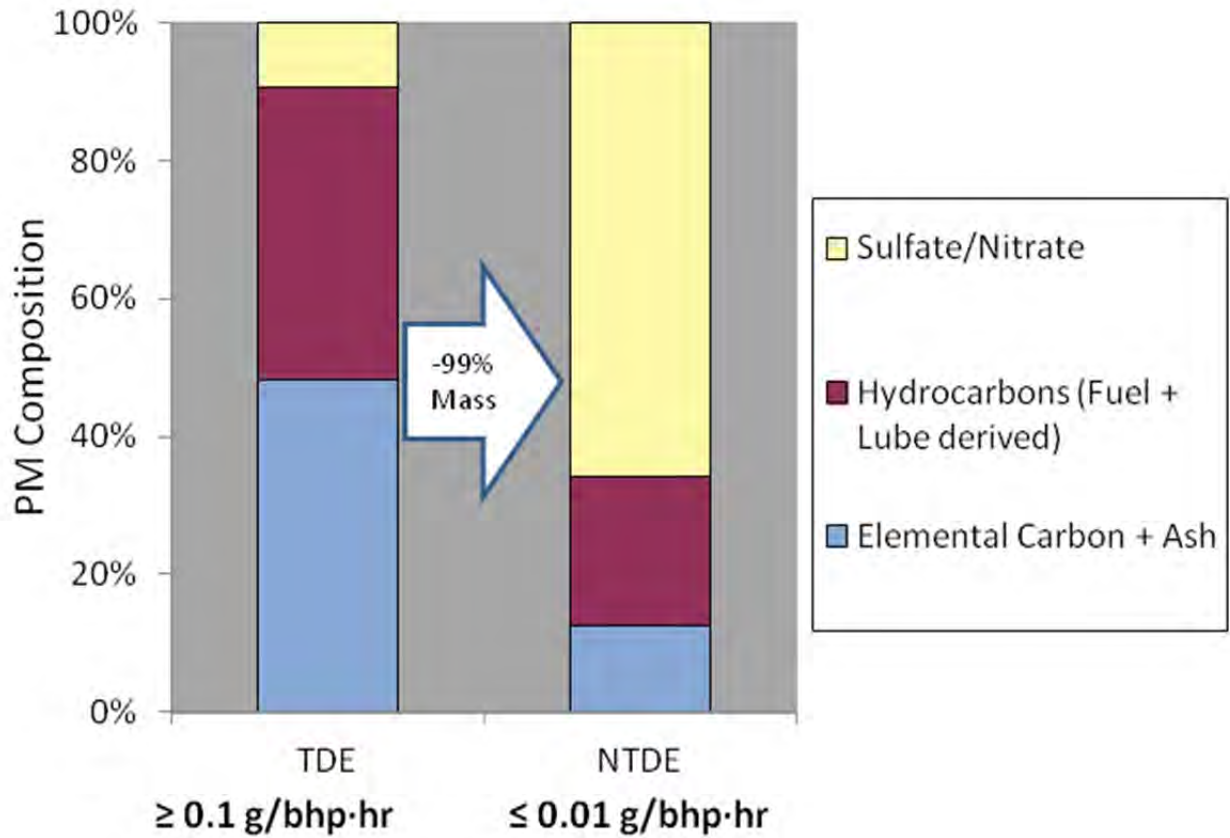

Kittelsohn et al. (2006b) conducted a study in which the sulfur content of the diesel fuel varied from 2 up to 44ppm S. Nitrate, volatile organics and carbon fractions were relatively constant for all the sulfur levels while the sulfate fraction increased monotonically with increasing fuel sulfur concentration (**Figure 12**). It is noteworthy that the EC fraction was extraordinarily low.

Figure 12: Measured PM emissions (carbon, volatile organics, sulfate and nitrate) continuously regenerating DPF from a heavy duty diesel engine as a function of fuel sulfur content (adapted from Figure 3 in Kittelson et al. (2006a)).

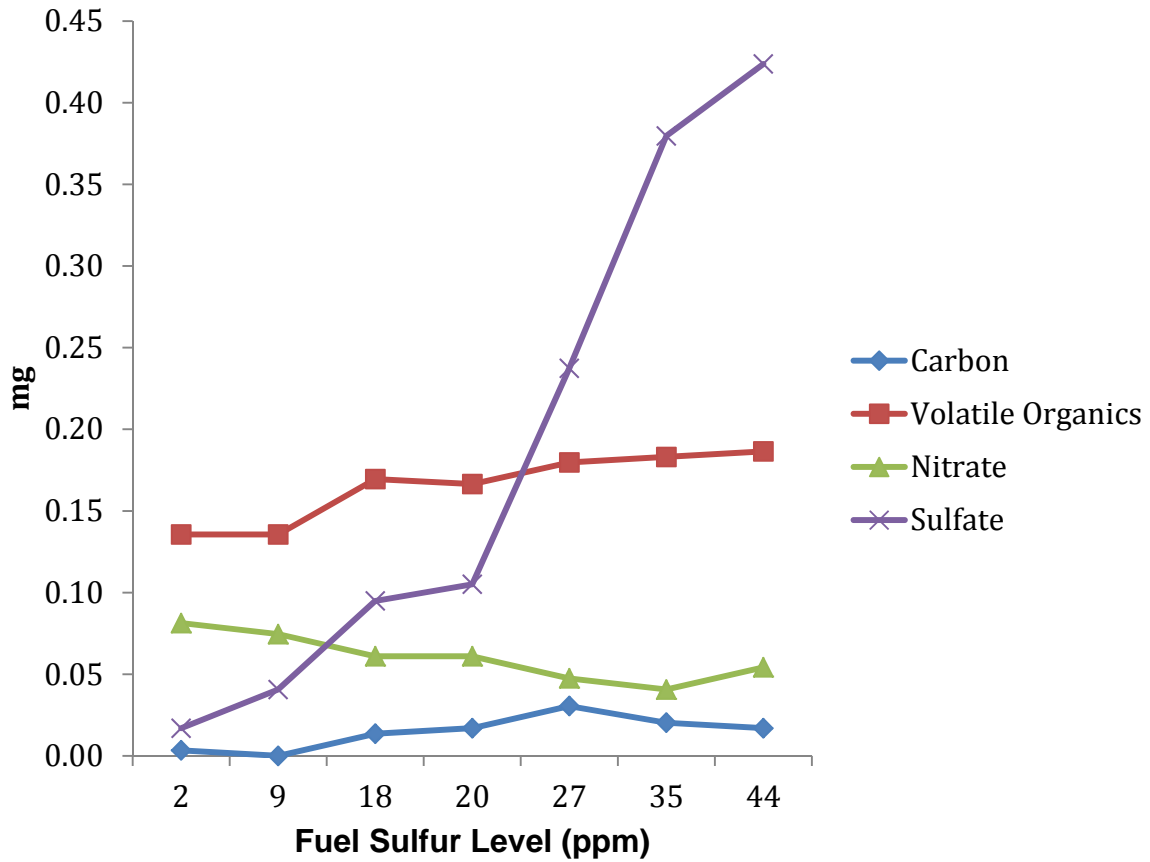

Groese et al. (2006) has shown that the nanoparticle emissions contained in NTDE are predominantly ammonium sulfates and sulfuric acid, which are fully water-soluble. Soluble sulfate particles, which will tend to dissolve in the lungs, are of low toxicity. (Grahame et al. (2005); Reiss, et al. (2007); Schlesinger, et al. (2003), (2007)).

In summary, NTDE represents four orders of magnitude reductions in EC and more than 99% reductions in OC compared to unregulated TDE. The content of any remaining nucleation mode particles in NTDE is dominated by sulfate, and, to a lesser extent, volatile organics. Accordingly, another assumption relating to the composition of TDE -- that diesel PM is dominated by a solid carbon core and high levels of organic carbon compounds -- is not appropriate to NTDE.

8.3.2 Significant Reduction and Elimination of PAHs in NTDE

Another key premise in the earlier review (IARC (1989)) of the health effects potentially attributable to TDE was that it contained “many PAHs” and “at least 10 times more

nitroarenes than gasoline engines." The IARC Monograph (Vol. 46) identified 60 agents in engine exhaust (not specified as to whether it was diesel or gasoline engine exhaust, or both) that had been evaluated by IARC. CARB (1998a), (1998b), (1998c), (1998d) identified over 40 components of TDE that had been listed as toxic air contaminants (TAC) or hazardous air pollutants (HAP) by U.S. EPA and other agencies.

The speciated emission components of NTDE are, again, fundamentally different from what was assumed to be present in TDE. Khalek et al. (2011) found that the 40 TACs previously thought to be in TDE were reduced in NTDE by up to 99% or are present in amounts at or below the detection limit (**Table 5**).

Table 5: CARB TACs: average emissions for all twelve repeats of the 16-hour cycles for all four 2007 ACES Engines, and for 1994 to 2000 technology engines running over the U.S. FTP (Khalek et al. (2011))

TAC No.	Compound	^d 1994 to 2000 Technology Engines	^a 2007 Technology Engines	% Reduction
		(mg/bhp-hr)	(mg/bhp-hr)	
1	Acetaldehyde	10.3	0.61 ±0.27	93
2	Acrolein	2.7	<0.01	>99
3	Aniline	c	0.000150 ±0.000075	c
4	Antimony compounds	c	<0.001	c
5	Arsenic	c	<0.0002	c
6	Benzene	1.82	<0.01	>99
7	Beryllium compounds	c	<0.0003	c
8	Biphenyl	c	0.013780 ±0.001716	c
9	Bis[2-ethylhexyl]phthalate	c	b	c
10	1,3-Butadiene	1.7	<0.01	>99
11	Cadmium	c	<0.00003	c
12	Chlorine (chloride)	0.18	<0.007	>96
13	Chlorobenzene and derivatives	c	b	c
14	Chromium compounds	c	0.0007 ±0.0003	c
15	Cobalt compounds	c	<0.0001	c
16	Cresol isomers	c	0.02727 ±0.01233	c
17	Cyanide compounds	c	<0.05	c
18	di-n-Butylphthalate	c	b	c
19	Dioxins and dibenzofurans	0.000066	0.00000066 ±0.000000055	99
20	Ethylbenzene	0.49	0.05 ±0.04	90
21	Formaldehyde	25.9	1.90 ±1.01	94
22	Hexane	0.14	< 0.01	>93
23	Inorganic lead	0.0009	<0.0001	>89
24	Manganese	0.0008	<0.00022	>73
25	Mercury	c	<0.00016	c

26	Methanol	c	0.07 ±0.13	c
27	Methyl ethyl ketone	c	<0.01	c
28	Naphthalene	0.4829	0.0982000 ±0.0423000	80
29	Nickel	0.01	0.0002 ±0.0001	98
30	4-Nitrobiphenyl	c	<0.00000001	c
31	Phenol	c	0.00905 ±0.00414	c
32	Phosphorus	c	0.0130 ±0.0064	c
33	POM (Polycyclic Organic Matter), including PAHs and derivatives	See Table 11	See Table 11	See Table 11
34	Propionaldehyde	1.8	0.01	>99
35	Selenium	c	<0.0001	c
36	Styrene	0.73	<0.01	>99
37	Toluene	0.64	0.26 ±0.28	59
38	Xylene isomers and mixtures	2.2	0.35 ±0.10	85
39	o-Xylene	0.99	0.13 ±0.07	87
40&41	m&p-Xylenes	1.21	0.20 ±0.08	83

^aThe significant figures signify the detection limit in mg/bhp-hr

^bNot Measured

^cNot Available

^dStandard deviation data were not provided by references 15 and 16

These results -- like all of the other results reported from the ACES Phase 1 program -- are significant because they were obtained with engines operating on a rigorous 16-hour test cycle (including urban, creep, transient and cruise mode conditions). That cycle was specifically designed to generate higher-end emission levels (Clark et al. (2007)) as compared to emissions from engines operated over the 20-minute FTP transient engine-certification test cycle.

Similarly, a comparison of a 2004 transitional model year engine and a 2007 model year engine equipped with a catalyzed DPF aftertreatment system and a crankcase ventilation coalescer has shown that NTDE contains significantly lower levels of many compounds that could be identified and quantified in the 2004 model year engine. That includes compounds such as formaldehyde and acetaldehyde (Liu et al. (2009b)). Many of the compounds were below the limits of detection (**Table 4**). The catalyzed exhaust after-treatment system and crank case ventilation coalescer are typical of those used in commercial 2007 on-road heavy-duty vehicles.

As shown in **Figures 13, 14 and 15**, when the emissions of the 2007 engine with contemporary emission controls were compared to the emissions from the 2004 transitional engine, there was a marked reduction in polycyclic aromatic hydrocarbons (PAHs), nitro-PAHs, and oxy-PAHs (Liu (2010), Khalek et al. (2009, 2011)). As a specific example,

benzo(a)pyrene was detected at $0.0797 \pm 0.0378 \mu\text{g}/\text{bhp}\cdot\text{hr}$ in the exhaust from the 2004 transitional engine, compared to $<0.00613 \pm 0.00469 \mu\text{g}/\text{bhp}\cdot\text{hr}$ in the exhaust from the 2007 engine. This represents a 92% reduction of benzo(a) pyrene. (Table 4).

Figure 13: Reduced concentrations of PAH emissions from a 2007 diesel engine with contemporary emission controls compared to emissions from a 2004 engine without contemporary emission controls (Liu et al. (2010)).

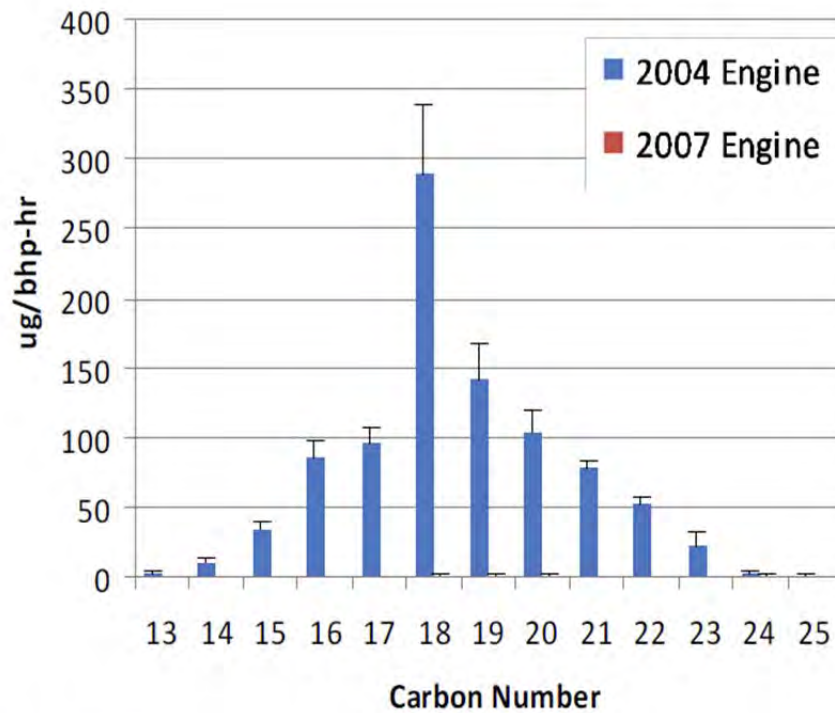

Liu et al., 2010

Figure 14: Concentration of nitro-PAH from a 2007 model engine with contemporary emission controls compared to 2004 model engines without contemporary emission controls (left), Liu et al. (2010) and 2007 model (ACES engines) compared to 2000 model engines (right) (Khalek et al. (2009, 2011)).

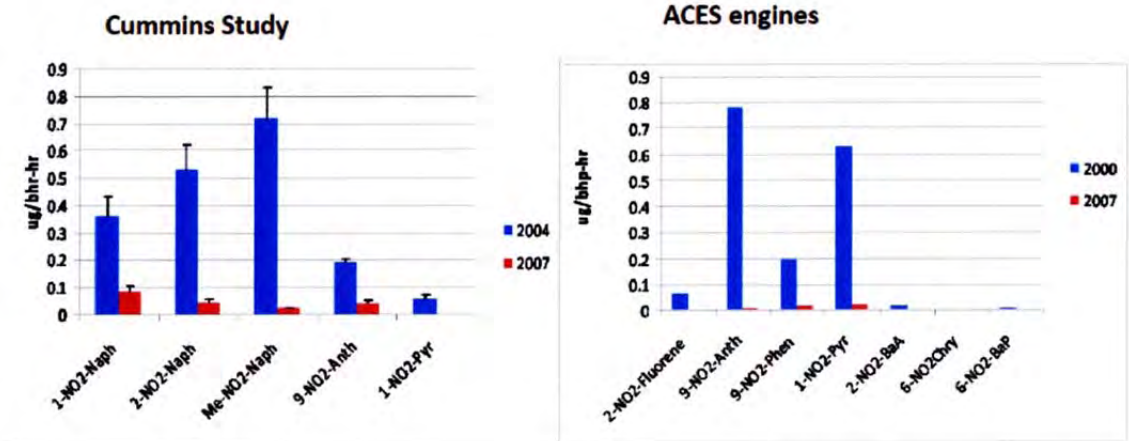
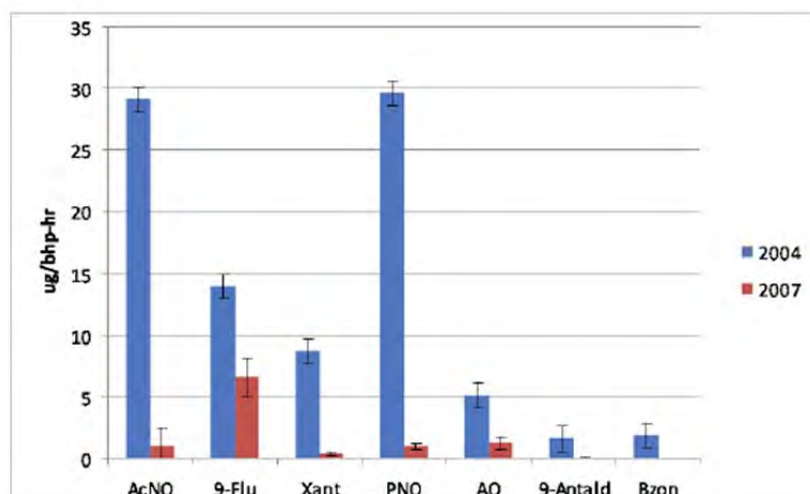

Figure 15: Concentration of oxy-PAH from a 2004 model engine without exhaust after-treatment compared to 2007 model with contemporary controls (Liu et al. (2010)).



AcNQ:acenaphthenequinone; 9-Flu:9-fluorenone; Xant: xanthone; PNQ:perinaphthanone; AQ: anthraquinone; 9-antal: 9-anthraaldehyde; Bzon:benzanthrone

Liu et al., 2010

As detailed in **Table 3** (Khalek et al. (2011)), NTDE contains substantially less PAHs than found in the emissions from earlier model year engine technologies. Specifically, PAHs with more than four rings (except fluoranthene and pyrene) have been reduced below the detection limit, and nitro-PAH compounds have been reduced by 99%. Again using the benzo(a)pyrene as an example, the exhaust from the 2000 engine contained a level of <0.0003 mg/bhp-hr for benzo(a)pyrene, which was reduced to below the detection limit for these experiments (<0.0000001mg/bhp-hr) in the exhaust from the 2007 diesel engine (**Table 6**).

Table 6: PAH and nitro-PAH average emissions for all twelve repeats of the 16-hour cycles for all four 2007 ACES engines, and for a 2000 technology engine running over the U.S. FTP (Khalek et al. (2011))

PAH and nitroPAH Compounds	^{a, b} 2000 Technology Engine mg/bhp-hr	^a 2007 Engines mg/bhp-hr	% Reduction
Naphthalene	0.4829	0.0982000±0.0423000	80
Acenaphthylene	0.0524	0.0005000±0.0005000	98
Acenaphthene	0.0215	0.0004000±0.0001000	98
Fluorene	0.0425	0.0015000±0.0009000	96
Phenanthrene	0.0500	0.0077000±0.0025000	85

Anthracene	0.0121	0.0003000±0.0001000	97
Fluoranthene	0.0041	0.0006000±0.0006000	85
Pyrene	0.0101	0.0005000±0.000400	95
Benzo(a)anthracene	0.0004	<0.0000001	>99
Chrysene	0.0004	<0.0000001	>99
Benzo(b)fluoranthene	<0.0003	<0.0000001	>99
Benzo(k)fluoranthene	<0.0003	<0.0000001	>99
Benzo(e)pyrene	<0.0003	<0.0000001	>99
Benzo(a)pyrene	<0.0003	<0.0000001	>99
Perylene	<0.0003	<0.0000001	>99
Indeno(123-cd)pyrene	<0.0003	<0.0000001	>99
Dibenz(ah)anthracene	<0.0003	<0.0000001	>99
Benzo(ghi)perylene	<0.0003	<0.0000001	>99
2- Nitrofluorene	0.0000650	0.00000360±0.00000410	94
9-Nitroanthracene	0.0007817	0.0000148±0.0000213	98
2-Nitroanthracene	0.0000067	0.00000040±0.00000090	94
9-Nitrophenanthrene	0.0001945	0.00002110±0.00002090	89
4-Nitropyrene	0.0000216	<0.00000001	>99
1-Nitropyrene	0.0006318	0.00001970±0.00002430	97
7-			
Nitrobenz(a)anthracene	0.0000152	0.00000020±0.00000020	99
6-Nitrochrysene	0.0000023	<0.00000001	>99
6-Nitrobenzo(a)pyrene	0.0000038	<0.00000001	>99

^aThe significant figures signify the detection limit in mg/bhp-hr

^bStandard deviation data were not provided by Khalek et al. (2011)

8.3.3 Semi-Volatile Organic Fraction (SOF) of NTDE is Significantly Different than TDE SOF

The 1988 IARC Monograph (IARC (1989)) also assumed that the sponge-like structure and large surface area of the EC particles in TDE made them an excellent carrier for organic compounds of low volatility, and that those compounds resided on the particulate surface (as a liquid) or were included inside the particle, or both. Other assumptions were that the majority of the soluble organic fraction (SOF) was adsorbed onto the surface of the EC core, that the SOF accounted for up to 45% of the total PM mass, and that the sulfate fraction of TDE PM could contribute up to 14 percent of the diesel exhaust particle.

The ACES Phase 1 study (Khalek et al. (2011)) has demonstrated that the EC particles and the semi-volatile compounds (SVCs) contained in NTDE have been reduced to extremely low levels. Average emissions over the four 2007 engines indicate total PM levels of 0.0014g/bhp-hr (**Table 2**); levels of semi-volatiles averaged over the same engines were 7.5µg/bhp-hr (**Figure 16**). Thus the semi-volatile organic fraction is only 0.5% of the total PM, which itself is more than 99.9% reduced relative to TDE. Of that small amount, alkanes (45%) and polar compounds (31%) dominate. PAHs, hopanes and steranes are less than

10% of the 0.5%, on the order of 0.5ug/bhp-hr. Nitro-PAHs and oxy-PAHs are below 0.1µg/bhp-hr, or approximately 1% of the semi-volatile phase.

Figure 16: Average particle phase semi-volatile emission rate and composition for all twelve repeats of the 16-hour cycles using all four ACES engines (Khalek et al. (2011)).

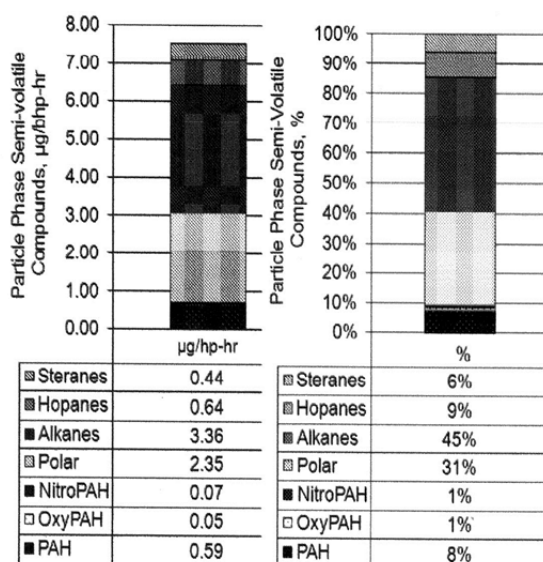

When compared to TDE, NTDE has 99% reductions in a wide variety of PAH compounds, including both semi-volatile low molecular weight three- to four-ring PAHs, as well as medium to higher molecular weight PAHs, which are generally below the detection limit (Liu et al. (2008a); Pakbin et al. (2009)). NTDE also has 96%-98% reductions compared to TDE in other particulate organic species, including n-alkanes, hopanes, and steranes (Pakbin et al. (2009)). Similar reductions of C₁, C₂, and C₁₀ through C₃₃ particle-phase and semi-volatile organic compound species in NTDE were noted by Liu et al. (2010) (**Table 4**).

8.3.4 NTDE Contains Significantly Lower Amounts of Other Unregulated Pollutants than TDE

The 1988 IARC Monograph (IARC (1989)) also assumed that TDE contained a significant amount of several unregulated pollutants of concern. The ACES Phase 1 measurements for a number of classes of compounds of interest are shown in **Tables 3** and **6** (Khalek et al. (2011)). Even using conservative estimates from the various measurement techniques used in the ACES program, NTDE exhibits substantial reductions (71% to 99%, in some cases to the limit of detection) in the emissions of unregulated pollutants when compared to 2004 transitional technology engines. Moreover, particle-bound trace metals and elements also have been reduced by an average of 98% in NTDE (Khalek et al. (2011)). In comparison to pre-1988 TDE, the NTDE reductions would be even greater.

Furthermore, as shown in **Table 6** (Khalek et al. (2011)), NTDE contains substantially less PAHs than found in emissions from earlier model year engine technologies. As noted, PAHs with more than four rings (except fluoranthene and pyrene) have been reduced below the detection limit, and nitro-PAH compounds have been reduced by 99%.

Accordingly, the exhaust emission compounds of potential concern for producing health effects have been reduced to near-zero levels in NTDE. It is also apparent that the NTDE aftertreatment systems are not resulting in the formation of other potential contaminants based on the extensive chemical characterizations of NTDE performed to date. If unique chemical species are present in NTDE, they are at extraordinarily low concentrations. The net result is that the amounts of both regulated and unregulated compounds contained in NTDE are very similar to those found in the emissions from advanced-technology compressed natural gas engines equipped with exhaust catalysts (Hesterberg et al. (2008)).

At the same time, when compared against the exhaust from CNG-fueled engines, NTDE has significantly lower emissions of 1,3-butadiene (i.e., non-detect levels), benzene, toluene, and carbonyls (especially formaldehyde); similarly low emissions of PAHs; and significantly lower specific mutagenic activity, and mutagen emissions (Kado et al. (2005)).

Beyond traditional criteria pollutants and their constituents, Liu et al investigated potential dioxin emissions from copper zeolite (CuZ) - based SCR NO_x control systems on US 2010 engines, and demonstrated that no dioxin congeners were detected during standard FTP emission tests, and that even setting all non-detects to the detection threshold yielded diesel exhaust Toxic Equivalency Quotients (TEQs) that were at least three orders of magnitude below EPA's regulated emission levels for waste incinerators. (Liu (2011a), (2011b)).

8.3.5 Significantly Lower Nanoparticle Emissions in NTDE

Concern was expressed as early as the 1980s that more nanoparticles could be formed as a result of the then-emerging new diesel engine technologies, which could pose a potential health hazard. However, recent research has shown that nanoparticles are substantially reduced in NTDE compared to TDE.

Kittelson et al. (2006a), (2006b) used a novel on-road experimental setup to demonstrate the impact of exhaust after-treatment systems in reducing nanoparticle emissions from diesel engines. The ACES Phase 1 study similarly revealed that the average total number of particles in NTDE (from engines operating on the FTP transient cycle) was 99% lower than from a transitional 2004 technology engine (and 89% lower when operating on a cycle that triggers regeneration events) (**Figure 17**) (Khalek et al. (2011)).

Figure 17: Average PN emissions comparison between 2007 ACES engines with and without C-DPF regeneration and a 2004 technology engine without DPF or DOC (Khalek et al. (2011)). Note that the y-axis is a logarithmic scale.

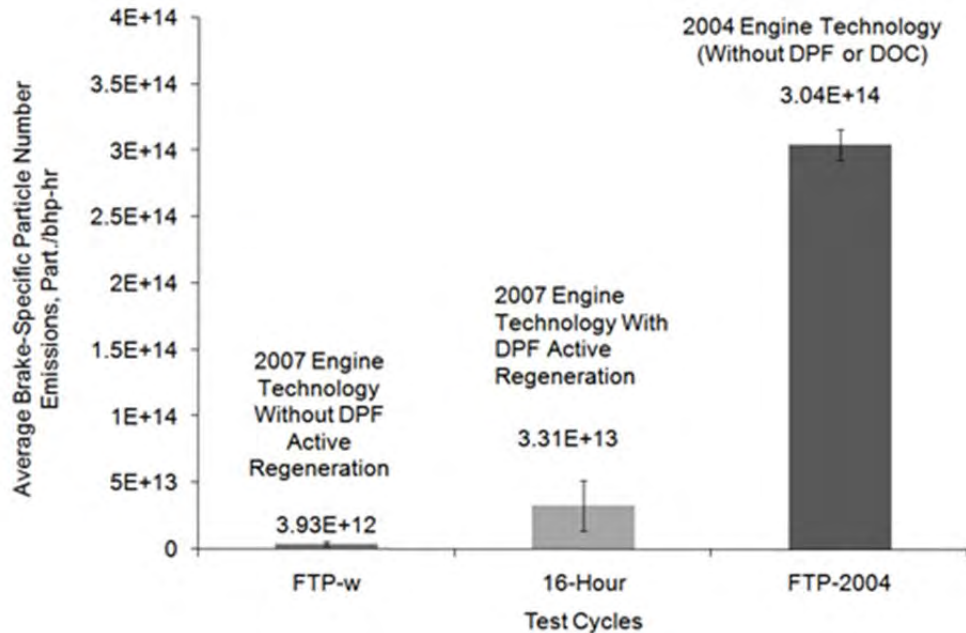
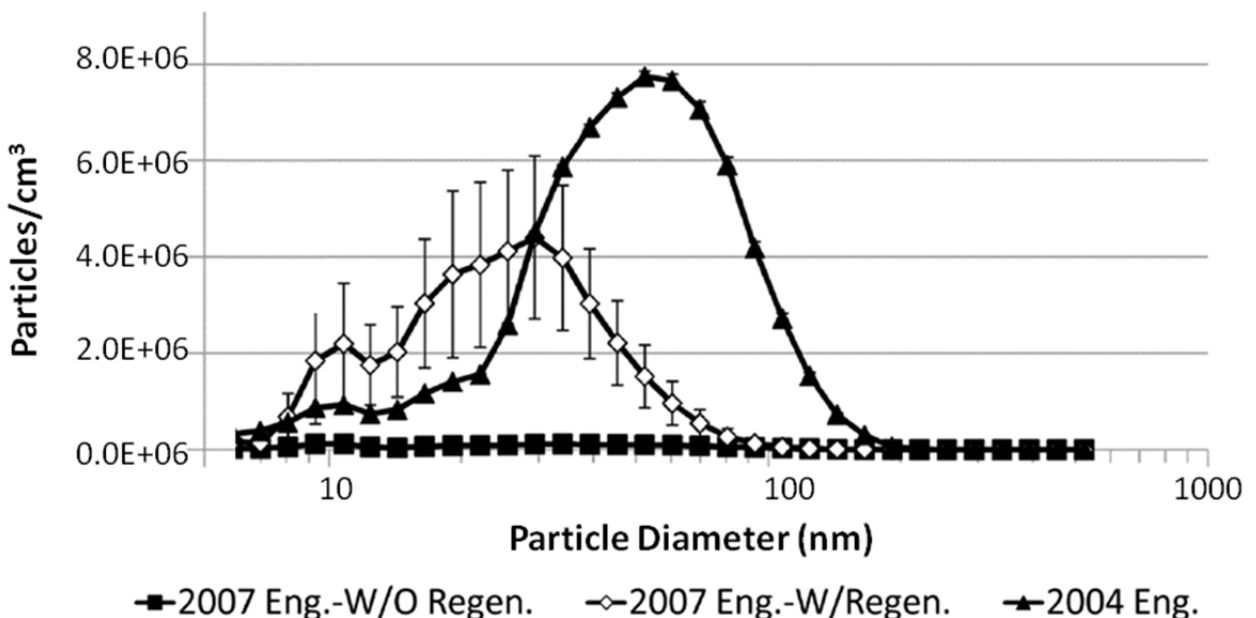

Figure 18: Average particle size distribution comparison between four 2007 ACES engines with and without C-DPF regeneration and a 2004-technology engine without a DOC or C-DPF (adapted from Khalek et al. (2011)). Note that the y-axis is a logarithmic scale.



An additional perspective on the influence of the C-DPF on the particle emissions is illustrated in **Figure 18** (Khalek et al. (2011)). In this figure, the average size distribution of particles is shown for a transitional 2004 engine operating without a C-DPF and a 2007

engine (compliant with EPA emission standards) with a C-DPF device. The geometric number mean diameter (GNMD) observed for the 2004 engine without a C-DPF was 46 nanometers. For the 2007 engine, particle size distribution data are plotted for 19 cycles when regeneration was occurring and 29 cycles without regeneration. The C-DPF affects particle number during both the cycles with and without regeneration. The net effect (which is not shown) will, of course, be a reflection of the portion of the total operating time that involves regeneration events. For the 2007 engine, the GNMD was reduced to 25 nanometers during regeneration and the number of particles emitted was reduced compared to the 2004 engine without a C-DPF. With the 2007 engine, the GNMD was 40 nanometers for the low number of particles emitted during the cycles when regeneration was not occurring. Khalek et al. (2011) also noted that the particle distribution measurements were made in the exposure chamber (without animals present) for the 2007 engines in ACES. In contrast, the measurements for the 2004 engine were taken in a constant volume sampler which would involve fresher exhaust. They speculate that the particle number emissions, especially of nuclei-mode volatile particle, for the 2004 engine would have been higher if the measurements had been made in an exposure chamber further downstream from the engine. They also note that the particle numbers would have been higher for the 2004 engine if it had been operating with a higher sulfur content fuel typical of the transitional pre-2007 time period. Thus, it is apparent that the number of particles contained in NTDE has been dramatically reduced – and even more so when compared with TDE (as opposed to a transitional 2004 model year engine).

In fact, the nanoparticle number concentration emissions contained in NTDE are well below typical urban ambient air concentrations, and amount to a 10,000-fold reduction when compared against older diesel engines not equipped with DPFs. (Barone et al. (2010)). Other studies have confirmed that the particle numbers contained in NTDE have been lowered to below ambient background levels (Kittelson, et al. (2006a), (2006b)).

In addition, under higher load conditions, the particle count from NTDE is essentially undetectable when compared against ambient background particle counts. Still other studies have confirmed that the particle number emissions contained in NTDE are more than three orders of magnitude lower than TDE and at least one order of magnitude lower than a gasoline vehicle. Bosteels et al. (2006) and Biswas et al. (2008) (see also Zheng et al. (2012) and Holmén et al. (2002), (2004) who reported that PN emissions from NTDE are, on average, two orders of magnitude lower than from TDE.)

In another recent study (Liu et al. (2007)) analyzing the impact of fuel sulfur content on PM emissions, lower nuclei-mode particulate emissions were observed when ULSD fuel

(<15ppm S) was used in place of low-sulfur (308ppm S) diesel fuel (**Figure 19**). It is apparent that the significant reduction of sulfur content in diesel fuel resulting from the adoption of the ULSD fuel standards (<15 ppm S) has played a role in reducing fine particle emissions, as well as allowing for the use of catalytic exhaust aftertreatment systems. Indeed, there are reports from Denmark (Wahlin et al. (2001)) and England (Jones et al. (2012)) that introduction of very low sulfur content diesel fuel in those countries resulted in substantial reductions in ambient air particle number concentrations soon after the low sulfur content fuel was introduced. Thus, the reduction in ambient PN was a reflection of the change in fuel sulfur levels even in the absence of any changes in the diesel engines.

Figure 19: Normalized total PN emissions during the entire U.S. FTP cycles for a 1992 TDE and a 2004 engine equipped with an EGR system operating on either ULSD (<15ppm S) and low-sulfur (308ppm S) diesel fuel, with flow rates of 0.7 or 1.3m³/S (Liu et al. (2007)).

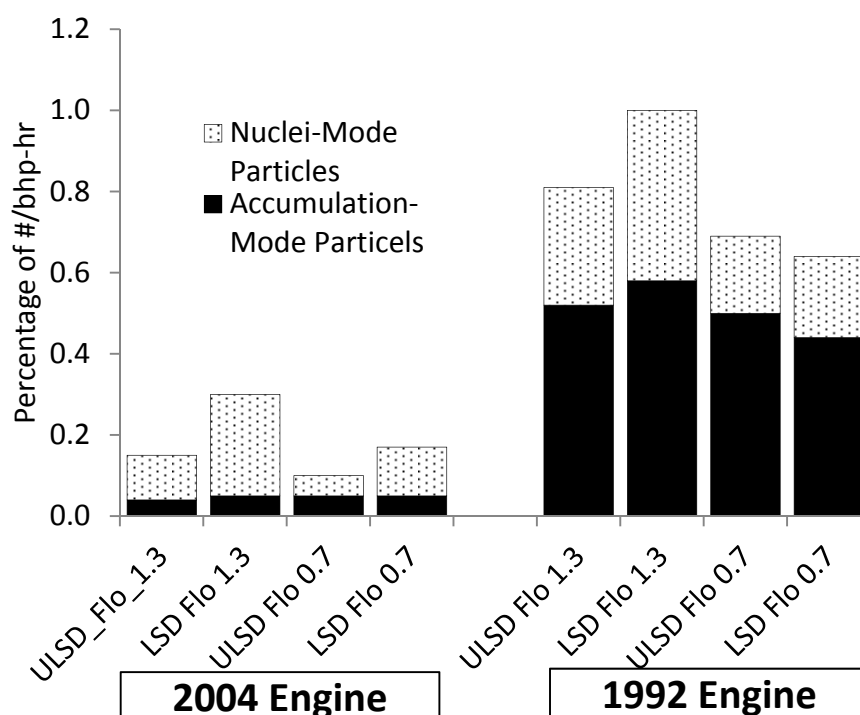

Herner et al. (2011) have investigated the role of both sulfur storage and exhaust temperature as determinants of the occurrence of nucleation mode particles. Their findings were reviewed by Hesterberg et al. (2011), (2012) who also noted the extent to which the trace concentrations of sulfate-rich particles should not cause direct toxicity or accumulate in the respiratory tract.

In summary, contrary to the concern that new diesel technologies (including DPFs) could augment the formation of nanoparticles, advanced DPFs operating on ULSD are effective in suppressing the PM nucleation mode. While absolute PN counts may vary from report to

report in the literature due to engine operating and exhaust sampling conditions, it is very clear that NTDE is substantially lower in nanoparticles emissions than TDE, by two to four orders of magnitude. Consequently, in this very important aspect, NTDE, resulting from the combustion of ULSD, is again fundamentally different from what was assumed to be the case for TDE.

8.3.6 Passenger Cars and NTDE

While the previous discussion centered on heavy-duty diesel engines and technologies, passenger car diesel engines equipped with DOCs and wall-flow DPFs and operating on ULSD fuel exhibit the same improvement in PM and composition as seen with heavy-duty engines.

Table 7 and **Figures 20** and **21** show that new technology diesel engines in European passenger cars resulted in 100-fold decreases in PM mass emissions and similar reductions in EC (Rose et al. (2010)). (In this reference, the reader is directed to the data labeled B0, indicating operation on conventional ultra-low-sulfur diesel fuel. The entire data set was developed in the context of a broader study of the impact of biodiesel fuel blends on emissions, which is not the primary subject of this paper.)

Table 7: Specifications of light-duty diesel vehicles in Rose et al. (2010) study (see also **Figures 20 and 21**)

Light-duty diesel vehicles

Vehicle characteristics	Vehicle 1	Vehicle 2	Vehicle 3
Model year	2009	2004	2005
Euro certification	Euro 4	Euro 4	Euro 4
Cylinders	4	4	4
Displacement	2.2L	2.2L	2.0L
Fuel injection system	Common rail direct injection	Common rail direct injection	Common rail direct injection
Transmission	Automatic	Manual	Manual
Diesel particulate filter (DPF)	Catalysed DPF with in-cylinder fuel injection	No DPF	Fuel-borne catalyst with in-cylinder fuel injection

Vehicle 3 is the 'golden vehicle' that was previously used in the European Particle Measurement Programme (PMP)¹

¹ Andersson, J., et al. (2007) Particle Measurement Programme (PMP): Light-Duty Inter-laboratory Correlation Exercise (ILCE_ID)—Final report (EUR 22775 EN) GRPE-54-08-Rev.1

Figure 20: Solid PN emissions from three European passenger cars (Rose et al. (2010))

Solid PN emissions: all vehicles

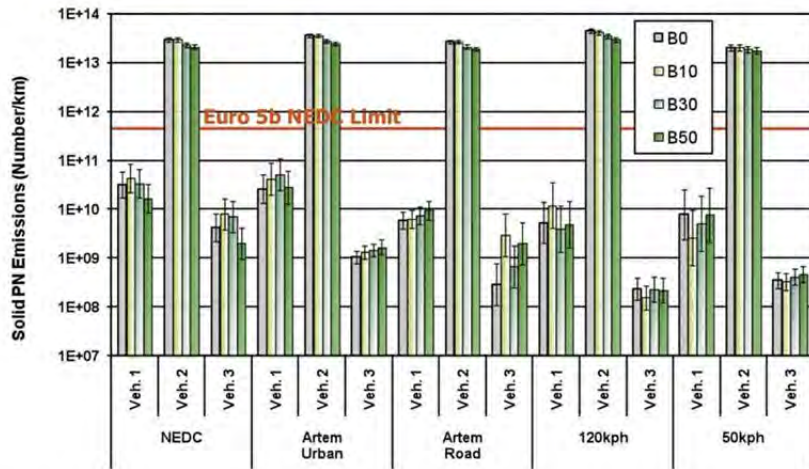

- Solid PN emissions about 1000 times higher from non-DPF-equipped vehicle compared to DPF-equipped vehicles.
- Small reductions in solid PN emissions with increasing RME (Vehicle 2).

Figure 21: Total PM mass and composition from three European passenger cars (Rose et al. (2010))

PM: all vehicles, NEDC

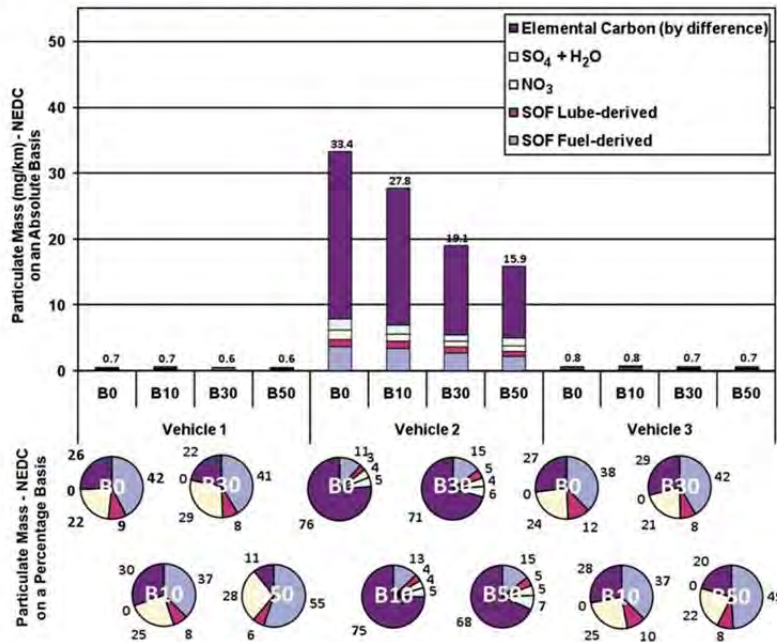

- Increasing RME content decreases tailpipe PM in Vehicle 2
- Elemental carbon dominates PM composition in Vehicle 2 compared to DPF-equipped vehicles

8.3.7 Summary -- NTDE PM is Fundamentally Different from TDE PM

The information reviewed above comparing NTDE to TDE has shown that in the case of technology-specific emissions (such as diesel engine exhaust), technological advances can have a profound impact on reducing and changing the composition of emissions. This situation is in sharp contrast to that for a particular chemical agent that has defined physical properties, including those that determine its hazard potential, which never change.

Major revolutionary advances have been made in diesel technology, especially during the last decade, which have impacted on exhaust emissions. Those advances which are integrated as a system include: (a) engine improvements, including the use of EGR; (b) use of low-sulfur and ULSD fuel; (c) exhaust aftertreatment, including DOCs and wall-flow DPFs; and (d) electronic sensing and computerized control systems. The new systems are extraordinarily effective in substantially reducing and changing the composition of PM exhaust as compared to TDE emissions. The key changes are: lower PM mass emissions, substantial reductions of the EC core, different chemical composition of the remaining PM fraction, lower PN emissions, altered composition of the semi-volatile fraction, and lower concentrations of unregulated pollutants. Thus, the NTDE emissions are substantially different, both quantitatively and qualitatively, from TDE emissions. In fact, the NTDE emissions are now similar to or lower than the emissions from modern CNG or modern gasoline-fueled engines.

A key assumption regarding TDE in the earlier IARC Monograph Vol. 46 (1989) was that diesel exhaust contained a number of toxicologically relevant compounds, such as benzene, toluene, xylene and PAHs, and that those PAH compounds were primarily absorbed onto particles. Significantly, much of the information regarding the genotoxicity of TDE was obtained using diesel exhaust particles or organic solvent extracts of diesel exhaust particles.

As detailed above, the nature and composition of diesel exhaust particles in NTDE have changed dramatically and fundamentally from the TDE (emitted from 1970s and 1980s-era diesel engines) evaluated earlier by IARC (1989). The EC core has been substantially reduced from NTDE. Instead, the very-low concentration nanoparticle emissions in NTDE have a sulfate-rich composition primarily associated with the nucleation of sulfates downstream from the after-treatment systems. This type of sulfate-rich composition differs from the hydrocarbon-rich composition associated with the nuclei mode particles in TDE (Tobias et al. 2001). The relative absence of insoluble EC, and the presence instead of a larger portion of sulfates, should result in the nanoparticles in NTDE being relatively

biosoluble compared to the EC rich particles in TDE. Given this biosolubility and the very low concentrations of NTDE particle mass, it is very unlikely that NTDE could result in any respiratory tract accumulation of PM. Furthermore, especially when considered in light of the extremely low concentrations of the organic compounds found in NTDE (if found at all), the earlier *in vitro* findings relating to TDE particles and their extracts are no longer germane to NTDE.

The extensive characterizations of NTDE have established that the emission levels from these engines are substantially lower than the applicable, stringent regulatory emission standards. Moreover, the detailed chemical characterization gives confidence that the emissions do not contain any unique constituents that might pose a hazard to human health. The new technology heavy-duty engines with ultra-low particulate emissions were introduced into the market for on-road use in 2007, as required by U.S. regulations, and have been well received by customers. Starting in 2010, the engines marketed in the U.S. continue to have ultra-low particulate mass emissions and, in addition, even lower NO_x emissions than the 2007 model engines. In future years, the number of NTDE units will increase and the number of TDE units will decrease in the on-road fleet. Moreover, a similar shift will follow for off-road diesel-power equipment.

9.0 LACK OF UNIQUE MARKERS AND SURROGATES FOR DIESEL EXHAUST EXPOSURES

9.1 HISTORIC DIFFICULTIES IN THE SEARCH FOR USEFUL MARKERS AND SURROGATES FOR DIESEL EXPOSURES

One of the key questions arising from efforts to characterize exposure to and the potential health effects of diesel exhaust is the challenge of identifying a relatively unique atmospheric marker or surrogate for diesel emissions that can be used to estimate exposures of the general population, and that can serve as a marker for retrospective estimations of exposures in longer term occupational epidemiology studies. The considerable effort required to measure particulates is widely known and reported in the literature, for example U.S. EPA 40 CFR Part 86 - Subpart N, U.S. EPA 40 CFR Part 1065, and the numerous papers on exhaust particulate measurements published by "Aerosol Science and Technology," "Atmospheric Environment," "Environmental Science and Technology," and "the Society of Automotive Engineers." Those papers, numbering in the thousands, provide strong evidence of the challenge of measuring exhaust particles, and thus partially explain why many investigators have attempted to discover robust surrogate measurements for direct particulate measurement.

The HEI Diesel Epidemiology Expert Panel (HEI (1999a)) noted significant limitations in the retrospective exposure assessments in both the trucking industry worker and railroad worker studies they analyzed, which contributed to HEI's conclusion that the studies were not suitable for quantitative dose-response and risk assessment.

In reviewing the results of the HEI-supported diesel exhaust and cancer feasibility studies, including two that focused specifically on the characterization of occupational exposures in mines and elsewhere, the HEI Diesel Epidemiology Work Group (HEI (2002a)) noted significant challenges with characterizing historical exposures. The Working Group had explored a number of potential chemical and atmospheric markers of diesel exhaust but concluded that even the most widely available and potentially relevant emission marker, elemental carbon, had significant limitations. They concluded: "The Working Group does not recommend proceeding with full studies of the populations considered here, *largely because of concern about the lack of available data from which one could estimate past exposures*" (emphasis added).

Following the Working Group report, HEI hosted a large, multi-disciplinary workshop - "Improving Estimates of Diesel and Other Emissions for Epidemiologic Studies" - to even

more broadly investigate potential markers of diesel exhaust. As before, that workshop concluded by re-emphasizing the significant limitations in the existing markers, and recommended a wide range of new research to try to fill the gaps (HEI (2002b)).

Due to the challenges encountered with measuring diesel particles, several investigators have attempted to substitute easier substances to measure. Attempting to find an easier metric for the evaluation of current and past exposures to diesel exhaust, other than EC or particulate matter, is certainly a desired objective. To that end, Xu et al. (2005) evaluated emissions from a number of diesel engines, and provided comparisons of particulates vs. real time PM instrument results, and PM levels vs. carbon monoxide, carbon dioxide and engine power, but none of those measures provided reasonable surrogates for diesel particulate, as **Figure 22** from those authors indicates. In sum, the measurement of diesel exhaust in ambient air and in occupational settings, both in contemporary settings and even more so in the case of historic reconstructions, remains inherently problematic.

Figure 22: Poor correlation between PM and CO (Xu et al. (2005))

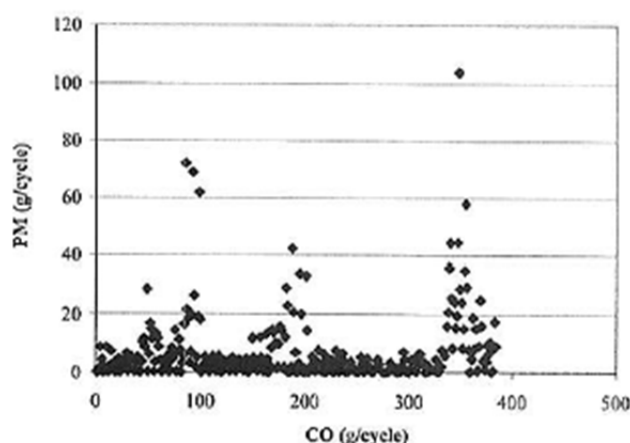

9.2 SPECIFIC PROBLEMS IN USING CO AS A SURROGATE FOR DIESEL EXPOSURES: THERE IS NO CROSS-ENGINE CORRELATION BETWEEN CO AND PM

More recently, a set of five exposure papers published in 2010 and 2012 chose to rely on CO as a surrogate for respirable elemental carbon (REC) in developing an exposure estimation methodology for a lung cancer epidemiology study of non-metal miners (Stewart et al. (2010); Coble et al. (2010); Vermeulen et al. (2010a), (2010b); and Stewart et al. (2012)).

In the absence of direct measurement of REC, the authors attempted to establish a useable CO-REC relationship. The papers made the following assumptions: (i) CO and PM emissions from different diesel engines correlate sufficiently well; (ii) historical CO emissions correlate sufficiently well with and can be estimated based upon aggregate engine horsepower; and (iii) the overall correlation of CO and PM emissions from different diesel engines is sufficiently proportional and linear to allow for 1:1 scaling over the years of the study. Significantly, none of these assumptions is correct, as can be demonstrated by the available technical data and analyses.

More specifically, emissions experts and the relevant peer-reviewed literature have conclusively established that there is no correlation between CO emissions and PM (or REC) emissions among different diesel engines and that the CO/PM relationship is unique for each engine type and perhaps for each engine (Clark et al. (1999)). The wide range of average CO/PM ratios is simply too great to allow the inference of PM directly from CO (Clark et al. (1999)), and data taken using a variety of test schedules, vehicles, engines, and geographic locations have shown that there is generally no reliable or unique relationship between CO and PM integrated over a test cycle (Clark et al. (1999), (2001)). Thus, there is no overall (fleet) relationship between CO and PM (Xu et al. (2005)). In particular, the CO/PM correlation coefficient for the relevant data sets -- older diesel engines -- was no higher than 0.12, and for some data sets the correlation was even negative (**Figure 23**, McKain et al. (2012)). Moreover, the slope of the regression lines for differing CO/PM data sets varies significantly, further underscoring that there is no sufficient correlation and linearity between CO and PM emissions from different diesel engines.

Figure 23: Cycle-specific PM against CO for tests on vehicles with Pre-1994 engines evaluated at 56,000 lb inertial weight over the UDDS driving schedule (appears as Figure 17 in McKain et al. (2012)).

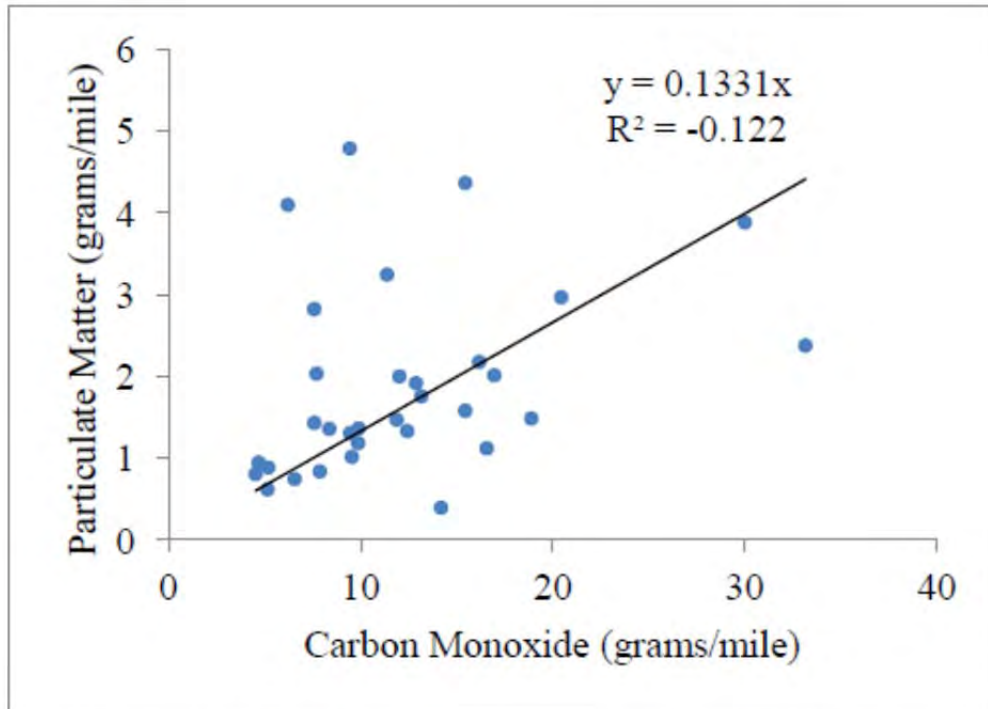

Figure 17 – Cycle-specific PM against CO for tests on vehicles with Pre 1994 engines evaluated at 56,000 lb inertial weight over the UDDS driving schedule.

McKain et al. (2012) evaluated a very large data set and compared PM with CO₂, HC, NO_x, engine power and CO. None of those non-PM measurements was able to provide a reasonable correlation with PM. “Despite these extraneous effects, two major truck databases (E-55/59 and Gasoline/Diesel PM Split) yielded weak correlations even in units of measure of grams/cycle when a linear regression was performed between PM and CO, and forced through the origin.” **Figure 24** illustrates the poor correlation of the elemental carbon (EC) fraction of PM with CO for engines from model years 1950-1975 (McKain et al. (2012)). McKain concluded, “a qualitative relationship may exist between PM and CO levels emitted by a group of engines, but correlations for datasets are weak. Moreover, the best fit line for one dataset did not generally describe well the relationship between PM and CO for another dataset.”

Figure 24: Cycle-specific EC fraction of PM versus CO for trucks with 1950-1975 model year diesel engines (appears as Figure 35 in McKain et al. (2012)).

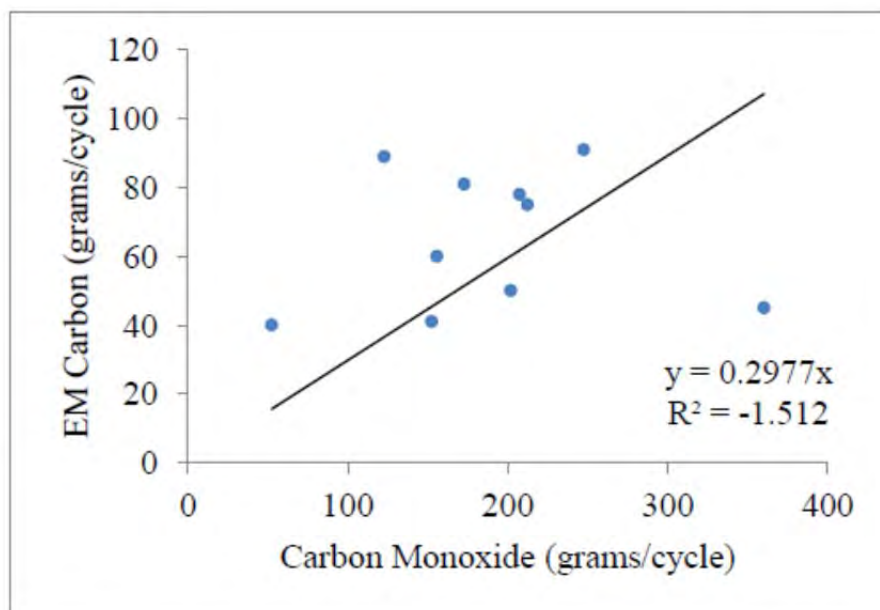

Figure 35 – Cycle-specific EC fraction of PM against CO for trucks with 1950-1975 model year diesel engines.

Clark and colleagues (Clark (2012)) are currently working on follow-up analyses examining the correlation between engine horsepower and CO among different engines and operating cycles. The preliminary results from that work have shown that “*quantitative prediction of PM emissions based on CO across engine technologies, duty cycles and fuel types results in significant errors.*”

Data from an entire year of Cummins engine certification-type testing across multiple engine platforms further reinforces the point. (**Figures 25** and **26**) These data are derived from engines tested on the U.S. FTP with PM emissions between 0.10 and 0.50g/bhp-hr to exclude tests with PM filters. The data show that there is no PM-CO correlation across engines and there is no correlation between CO and average cycle engine power. The correlation coefficient, r^2 , for PM to CO is zero (calculated as -0.04), and for CO to HP is 0.03. **Figure 27** shows the same Cummins PM-CO data plotted and analyzed in log-log format, as suggested by the DEMS authors (Vermeulen et al. (2010a, 2010b)) (in this case, \log_{10}) and shows an $r^2=0.09$. (Martin (2012)). For comparison, the CO-PM data set used for correlation by Vermeulen et al. (2010a, 2010b) is shown as **Figure 28**.

Figure 25: PM-CO linear correlation for all Cummins engines tested over the EPA HD transient and ramped modal cycles for PM between 0.1 and 0.5 in four CVS cells at the Cummins Technical Center in calendar year 2009 (Martin (2012))

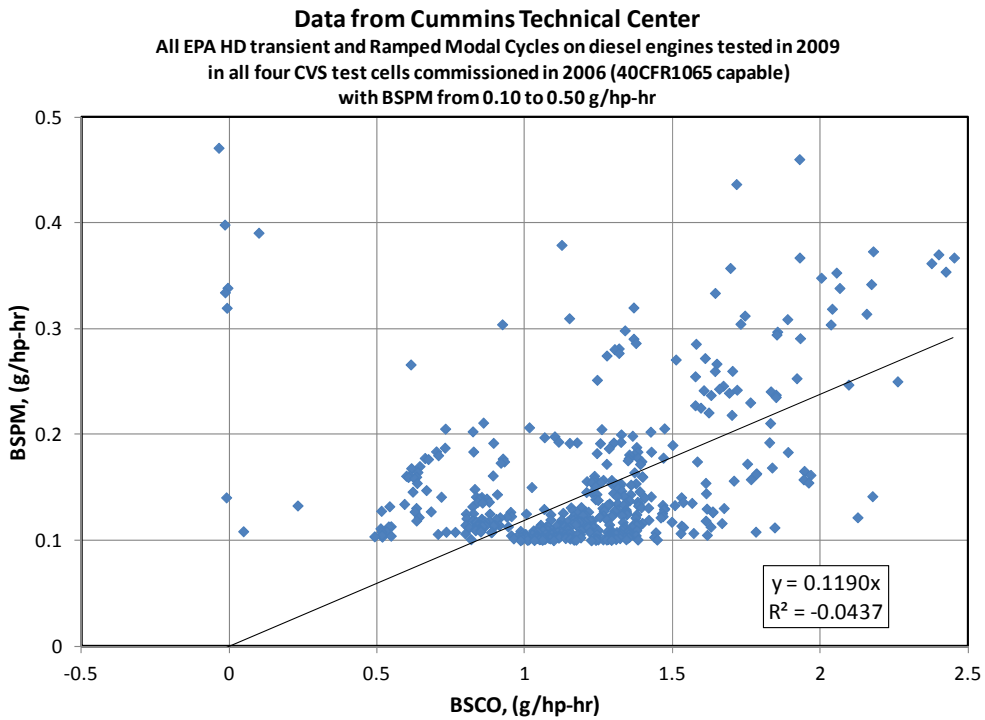

Figure 26: CO-average horsepower linear correlation for all Cummins engines with average hp above 25 tested over the EPA HD transient cycles in four CVS cells at the Cummins Technical Center in 2009 (Martin (2012))

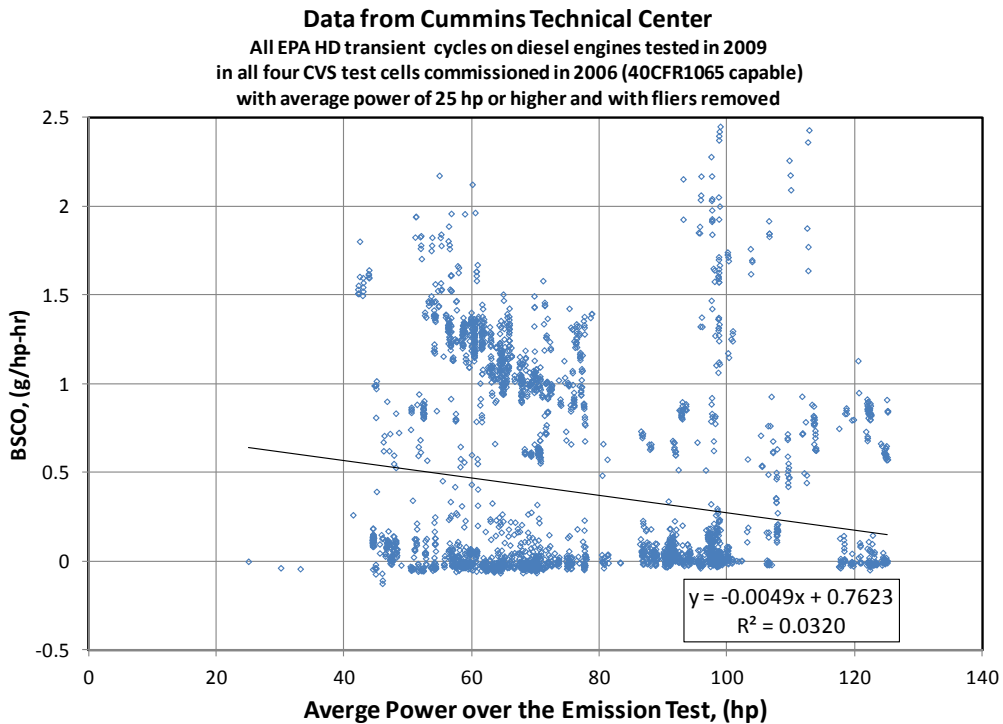

Figure 27: Log PM – Log CO correlation for all Cummins engines tested over the EPA HD transient and ramped modal cycles for PM between 0.1 and 0.5 in four CVS cells at the Cummins Technical Center in 2009 (Martin (2012))

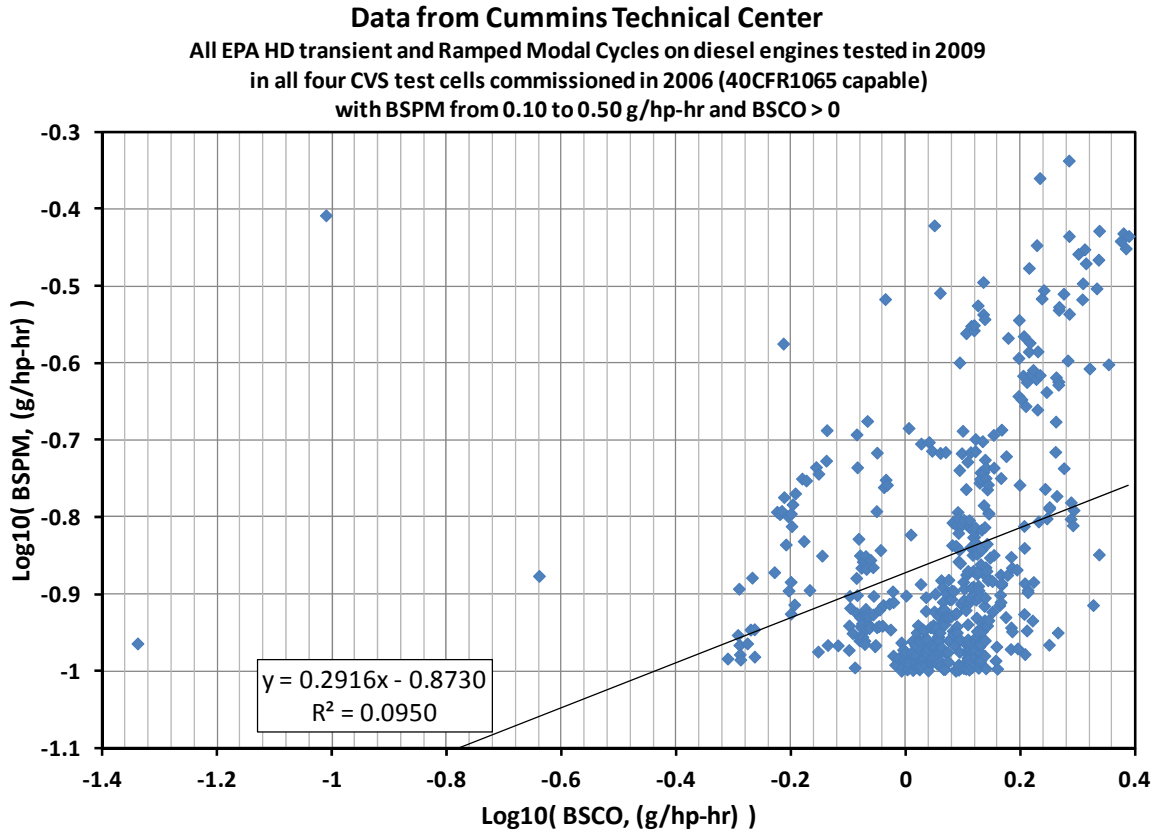
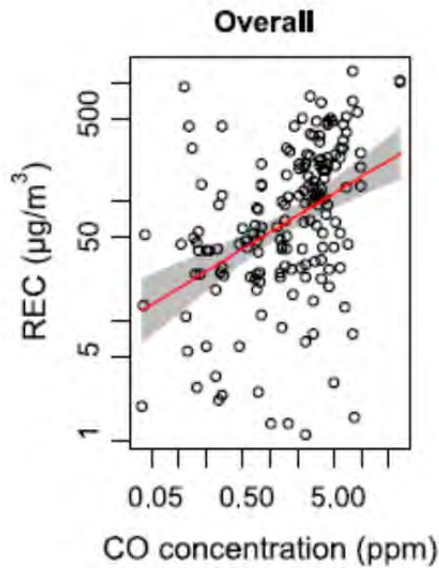

Figure 28: Scatter plot and regression analysis between natural-log transformed (Ln) CO and REC measurements for all mining facilities combined (from Fig.2, Vermeulen et al. (2010a), (2010b))



The DEMS authors have cited Haney (2000) and Yanowitz (2000) in constructing their surrogate-based estimates of REC exposure, which are derived from historical average engine horsepower, an assumed proportionality between CO estimations and engine power (which is incorrect as noted above), and an assumed 1:1 proportionality between REC estimations and CO estimations across engines (which is also incorrect, as shown above). Yanowitz (2000) acknowledges *“There is wide variability of emissions from in-use vehicles built under identical regulatory standards and even among identical engines ... CO emissions typically vary an order of magnitude in the same model year.”* The Haney (2000) Mining Safety and Health Administration (MSHA, US Department of Labor) model requires direct input of diesel particulate measurements at the work site or direct input of engine exhaust emission rates. Accordingly, neither of those papers recognizes or recommends CO as a useful surrogate or intermediary in estimating diesel exhaust exposures.

The Health Effects Institute has properly noted, *“characteristics for the ideal signature for diesel emissions would include (1) specificity for diesel exhaust, (2) feasibility of measurement, (3) possibility of being generated from routinely collected data, (4) appropriate cost, (5) relative insensitivity to engine technology and fuel.”* (HEI (2002b)). CO fails as a marker against this set of criteria.

Accordingly, estimates of diesel particulate exposure based on CO measurements and assumed CO-to-HP and CO-REC correlations across engine families and average power output are fundamentally incorrect.

10.0 GLOBAL ADOPTION OF ADVANCED DIESEL EMISSION CONTROL STANDARDS

As noted previously, the U.S. and Europe have adopted increasingly stringent emission standards over the past two decades. These standards are being implemented at varying paces in other countries around the world (**Figures 29 and 30**, O’Keefe (2012)). This section describes the current state of adoption and implementation of emission standards on a global basis, and forecasts how low emission standards will continue to penetrate major vehicle markets around the world. (Walsh (2012)).

Figure 29: Global transition to more stringent emission standards over time (O’Keefe (2012)).

Continued Transition to Tighter Vehicle Emission Standards

Light-duty Vehicle Emission Standards

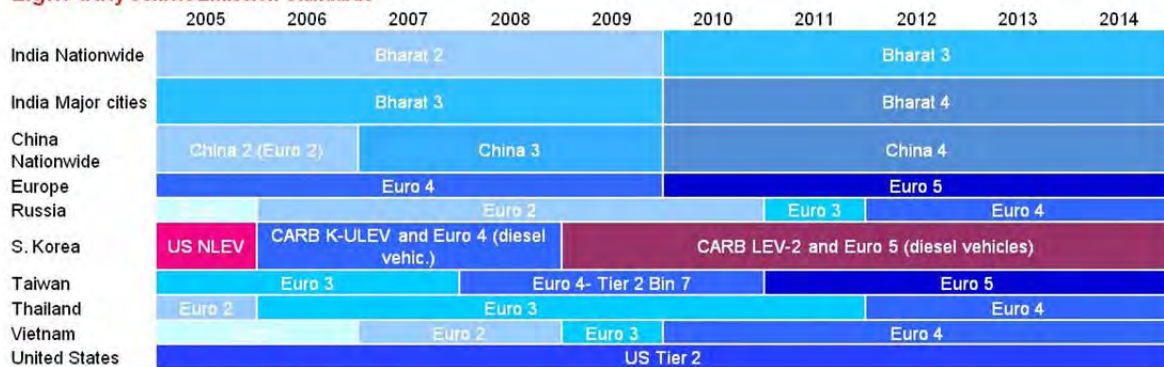

Heavy-duty Vehicle Emission Standards

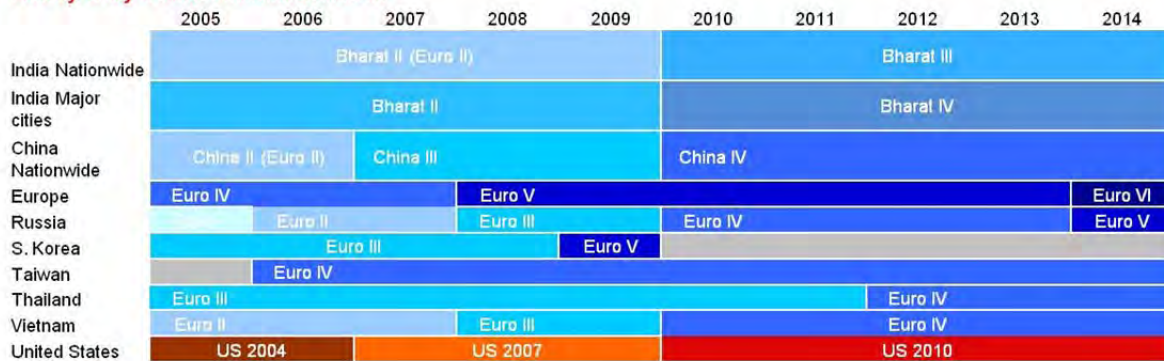

Figure 30: Current and projected global diesel fuel sulfur limits (O’Keefe (2012))

Expected Fuel Sulfur Standards

Diesel Sulfur Limits (parts per million)

		2005	2006	2007	2008	2009	2010	2011	2012	2013	2014
Euro pathway	Europe			50					10		
	Russia		2,000			350 ⁽²⁾		50 ⁽²⁾			10 ⁽²⁾
	S. Korea	100		30					15		
	Thailand				350						50
	China ⁽¹⁾			2,000						350	
	India			500						350	
	Urban cities ⁽³⁾			350						50	
Non-Euro pathway	Brazil		2,000				1,800 / 500 ⁽⁴⁾			1,800 / 500 / 50 ⁽⁴⁾	
	Japan		50					10			
	US	500					15				
	Canada	500					15				
	Mexico ⁽⁵⁾					500					ULSD

(1) Certain urban areas have had access to 50 ppm sulfur fuel since 2006 - this table reflects nationwide requirements.
 (2) The Ministry of Energy and Industry submitted draft regulations to move to Euro 3 fuel levels by 2009, Euro 4 by 2010, & Euro 5 by 2013.
 (3) Delhi, Mumbai, Kolkata, Chennai, Ahmedabad, Surat, Agra, Pune, Kanpur.
 (4) Currently 1,800 ppm fuel is available in rural areas and 500 ppm fuel is available in cities. Beginning in 2012 50 ppm fuel will be available in both rural areas and cities, but the higher sulfur fuels will also be available.
 (5) Ultra-low sulfur fuel with 15 ppm sulfur has been available in some border regions and large metro areas since 2007. A significant fuel sulfur reduction is planned for 2014, but implementing regulations not yet in place; final allowable sulfur level not yet determined.

References
 www.dieselnet.com
 CAI-Asia: http://www.cleantimet.org/caiasia/1412/articles-40711_SulfurDiesel.pdf
 Delphi - Worldwide Emission Standards 2009: Heavy Duty & Off-Road Vehicles
 UNEP - Partnership for Clean Fuels and Vehicles: <http://www.unep.org/pcfv/>

10.1 VEHICLE SALES

New vehicle sales in each country or region are dependent on several factors, with population growth, urbanization and GDP per capita being the most important. Based on those criteria and reviewing other estimates from IEA, the World Business Council on Sustainable Development, the International Council on Clean Transportation (ICCT), as well as individual country estimates, a forecast of future new vehicle sales was developed.

Between 2010 and 2030, sales of new light and heavy duty vehicles are expected to almost double with most of that growth occurring in the rapidly industrializing, developing world.

10.2 VEHICLE EMISSIONS REQUIREMENTS

The purpose of this section is to highlight the global regulatory trends with regard to heavy-duty vehicles and engines over the next decade. Two emissions standards scenarios were analyzed: a base case, and a forecast case.

10.2.1 Base Case

For the base case, only vehicle emissions standards that are currently adopted were included. The most important element of new requirements in this regard is the phase-in of the Euro VI heavy duty requirements over the next several years.

Over the last decade, China has gradually tightened its requirements for both vehicles and fuels. In some major cities such as Beijing and Shanghai, maximum sulfur levels are limited to 50ppm. Regarding heavy-duty vehicle standards, Euro IV-equivalent standards are scheduled to go into effect in 2013. Before the end of 2012, Euro V-equivalent standards will be introduced in Beijing along with diesel fuel with no more than 10ppm S. No decision has yet been made regarding the introduction of Euro V or Euro VI limits across all of China but pressure is building to move forward. In May 2010, the State Council issued guidance to all the major cities as well as the three major regions – Beijing/Tianjin/Hubei, the Yangtze River Delta and the Pearl River Delta – requiring them to achieve the “level 2” air quality standards by 2015. This will be difficult without a further tightening of new vehicle and engine standards. More recently, the 12th % Year Plan which runs from now to 2015 calls for a nationwide NO_x reduction of 10%. In order to allow some growth in the Western provinces, an even greater reduction will be needed along the East Coast where the motor vehicle population is concentrated. Achieving this NO_x target without further tightening of vehicle requirements will be very difficult.

India currently has similar requirements as China. In 2010, India introduced Euro III-equivalent standards nationwide along with diesel fuel with a maximum fuel sulfur content of 350ppm. In 13 major cities, Euro IV standards were introduced along with 50ppm S. Even though air quality levels remain very poor, there is no further vehicle emissions reduction roadmap under development at this time. ICCT is working closely with several organizations in India to develop the next phase of the roadmap.

Brazil was planning to introduce Euro IV-equivalent emissions standards and fuels in 2009. However, Petrobras did not meet its fuel sulfur commitment, so the vehicle standards were postponed. After intense negotiation between all parties it was decided to skip Euro IV and to go straight to Euro V emissions standards in 2012; this occurred on January 1 of this year. Simultaneously, 50ppm S diesel fuel was introduced in quantities sufficient to supply the new vehicles and this will drop to 10ppm S in 2013.

The global market penetration of the new heavy-duty diesel engine and vehicle standards, specifically accounting for requirements that have already been adopted in Europe and the U.S., is summarized in **Figures 31** and **32**.

Figure 31: Base case: Global trends in Heavy Duty Diesel emission standards – millions of vehicles worldwide (Walsh (2012))

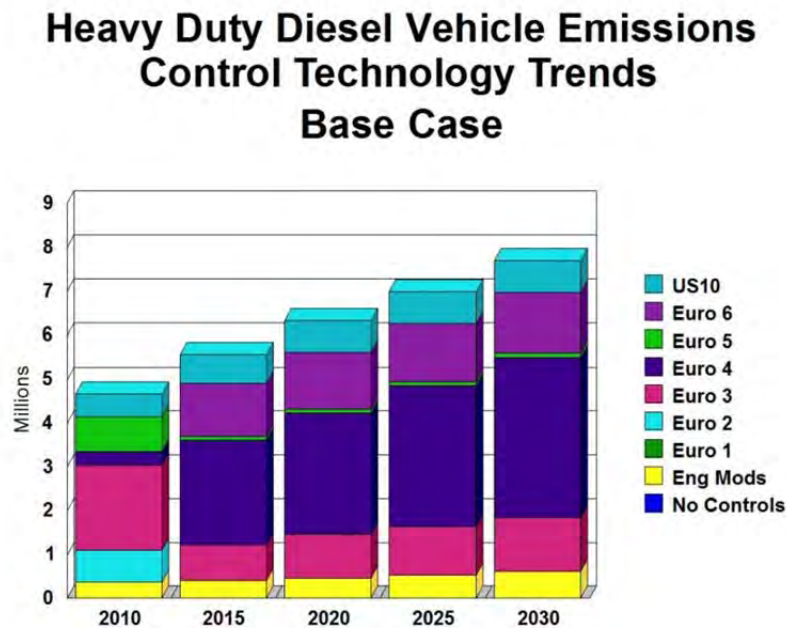
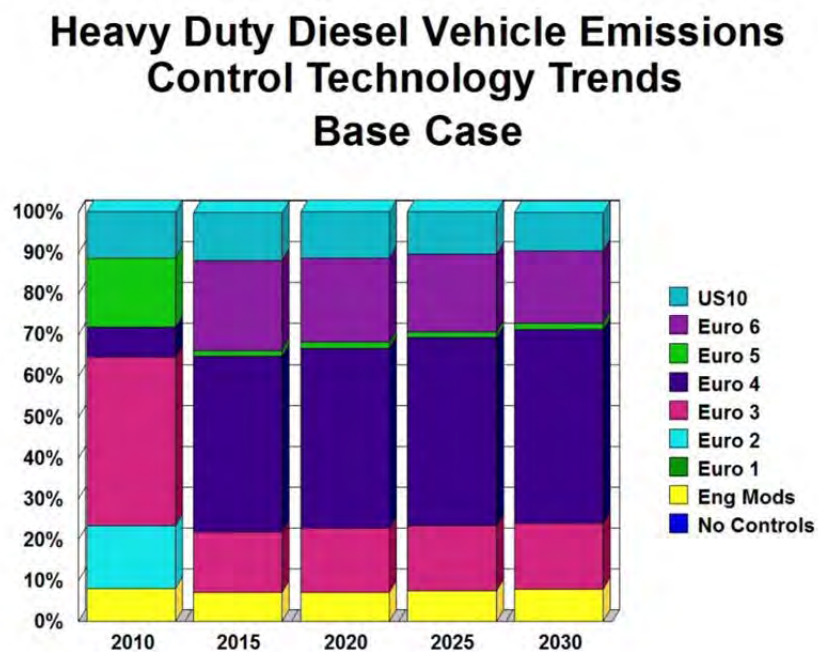

Figure 32: Base case: Global trends in Heavy Duty Diesel emission standards – percentage of vehicles worldwide. (Walsh (2012)).



10.2.2 Forecast Case

Of course, it is not reasonable to assume that countries will simply stop where they are in terms of vehicle emissions regulation and cleaner fuels, especially in light of the air pollution problems that remain. Therefore, a forecast case was developed based on a careful assessment of regulatory developments in various countries around the world. In this scenario, it was assumed that tighter standards are gradually phased in around the world, such that:

- Mexico adopts US 2010 standards by 2020
- Brazil adopts Euro VI standards by 2015
- Non-EU Europe, including Russia, and the remainder of Latin America adopt Euro V standards by 2020
- China and India adopt Euro V standards by 2015 and Euro VI standards before 2020
- The Middle East goes to Euro II by 2015 and Euro IV by 2020
- Africa adopts Euro II standards by 2015

The results of this forecast case are summarized in **Figures 33** and **34**.

Figure 33: Forecast case: Global trends in Heavy Duty Diesel emission standards – millions of vehicles worldwide (Walsh (2012)).

Heavy Duty Diesel Vehicle Emissions Control Technology Forecast

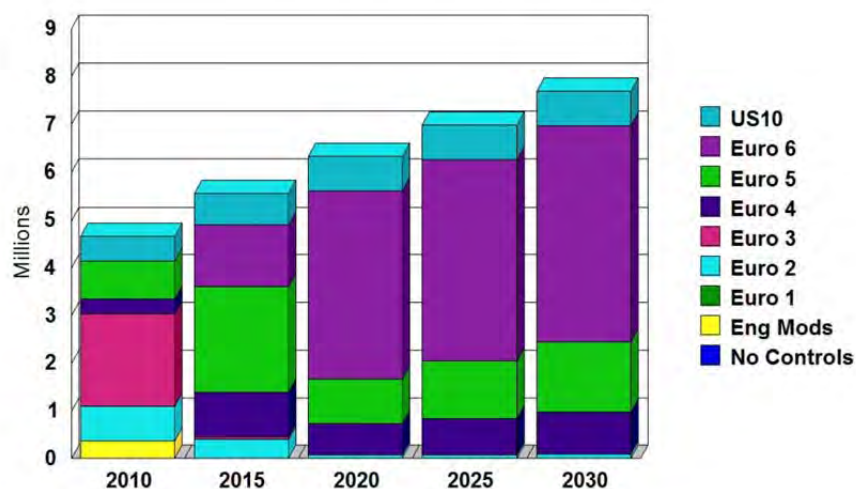
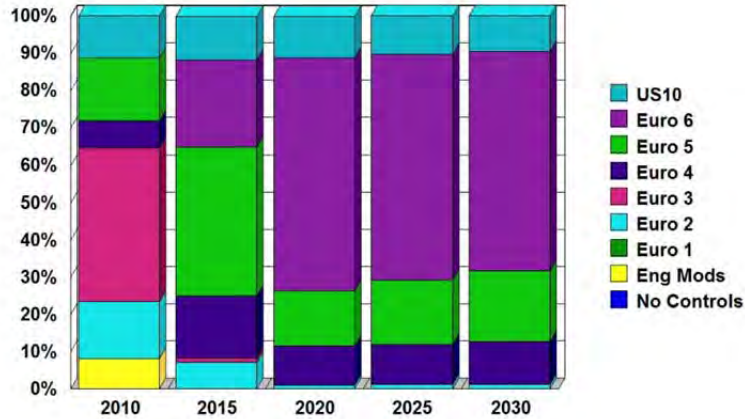

Figure 34: Forecast case: Global trends in Heavy Duty Diesel emission standards – percentage of vehicles worldwide (Walsh (2012))

Heavy Duty Diesel Vehicle Emissions Control Technology Forecast



In this forecast case, it is estimated that approximately 3 out of every 4 new trucks sold by 2020 will likely be equipped with either U.S. 2010 or Euro VI technologies emitting much less pollutants than most current heavy-duty trucks and buses (**Figure 35**).

Figure 35: Forecast 2020 Heavy Duty Diesel emission standards – percent of vehicles worldwide (Walsh (2012))

Heavy Duty Diesel Vehicle Emissions Control Technology in 2020

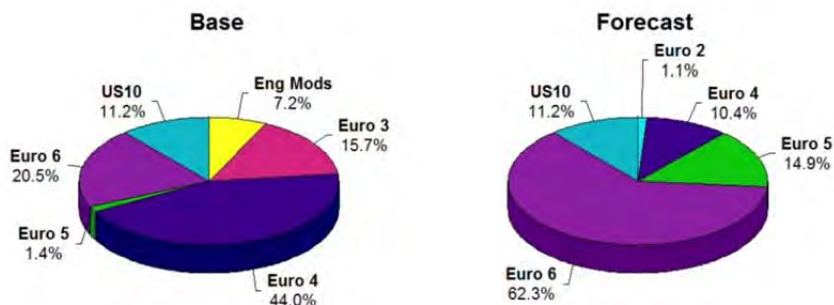

11.0 CONCLUSIONS REGARDING TDE AND NTDE

The use of diesel engines as reliable and efficient sources of power to move goods and people, and to meet many other critical needs of society has steadily grown over the past century. During the past half century, concerns arose over the impact of diesel engine exhaust on visibility and human health and more recently on climate change. Those concerns were soon reflected in increasingly more stringent regulations to limit engine emissions.

In response to and in support of the stringent emission-control regulations, the manufacturers of diesel engines and the refiners of diesel fuel made evolutionary and, more recently, revolutionary advances in diesel technology, including improved engines and exhaust after-treatment systems, and improved ULSD fuels.

New Technology Diesel Exhaust (NTDE) is defined as exhaust from engines with oxidation catalysts and wall-flow particulate filters, and operating on ULSD fuel. This new technology is being rapidly introduced into the market to replace traditional diesel engines and fuels. The particulate matter mass concentration in NTDE is two to four orders of magnitude lower than in TDE and the chemical composition of NTDE is distinctly different than that of TDE. The TDE particles illustrated earlier in **Figure 1**, with their characteristic core of EC and substantial amount of associated hydrocarbons, are simply not present in NTDE. Thus, it is clear that there have been major advances in the control of diesel exhaust emissions in response to progressively more stringent regulations.

In recognition of the fundamental differences in physical and chemical composition between NTDE and TDE, the data show a clear distinction between NTDE and TDE and warrant their consideration as substantially different products from a health perspective. Furthermore, preserving the clear distinction between NTDE and TDE will encourage the deployment of ultra-clean diesel technologies around the world, which in turn will yield continuing and profound improvements in ambient air quality and public health.

It should be noted that, just as has occurred over the past two decades, diesel engine systems and fuels continue to improve, and advanced technology emission reduction strategies continue to evolve. To the extent that other integrated advanced-technology diesel systems are developed that are capable of achieving an exhaust emissions profile for regulated and unregulated pollutants that is sufficiently equivalent to that for NTDE, the exhaust from those alternative advanced-technology diesel systems should be deemed as included within the scope of NTDE.

Quantification of PM exposure in epidemiological studies is difficult, especially if no direct measurements of respirable particulates are available. Identification of reliable surrogates has been generally unsuccessful. Carbon monoxide, which has been proposed as a marker for exposure by some research studies, is not a direct surrogate nor is it reliable in correlating diesel particulate emissions across engine families. Accordingly, diesel exposure estimates based on a hypothetical CO-to-REC correlation are fundamentally incorrect.

12.0 BRIDGING FROM EMISSIONS CHARACTERIZATION TO EVALUATING POTENTIAL HUMAN HEALTH IMPACTS OF EXPOSURE

The focus of this document has been on the physical and chemical characterization of diesel exhaust, and especially the evolutionary and revolutionary advances in the diesel system (engine, fuel, exhaust after-treatment and electronic controls) that have markedly reduced and altered the composition of the mix of exhaust constituents found in NTDE as compared to TDE. Especially notable has been the virtual elimination -- i.e., reduction to near levels of detection and sometimes below -- of PM from NTDE, especially the elemental carbon nanoparticles with associated hydrocarbons that are the hallmark of TDE. The challenge at hand is to understand what these remarkable changes mean in terms of potential human health impacts, particularly as they pertain to the IARC Monograph process.

IARC has used a four-pronged approach to evaluate the potential cancer hazard of nearly a thousand chemical agents. The IARC process is grounded in consideration of exposure characterization data and three additional kinds of evidence: epidemiological studies, laboratory animal bioassays, and investigations of mechanisms/modes of action of the agents. The IARC approach uses epidemiological data, when they are available, as the best and most reliable indicator of human cancer hazards. To supplement the epidemiological findings, data from well-conducted long-term cancer bioassays in laboratory animals are used to complement the epidemiological findings, or in the absence of epidemiological evidence, the animal data are used alone as predictors of human cancer hazards. To complement both the epidemiological and laboratory animal evidence, information on mechanisms or modes of action are evaluated.

The vast majority of the nearly 1,000 cancer hazard evaluations conducted by IARC have considered specific agents, most frequently specific chemicals. In those situations, as noted earlier, the inherent physical characteristics of the chemical that influence its carcinogenic hazard never change. The situation is quite different for an agent that is a complex mixture, such as diesel engine exhaust, which is produced by a technology that is being purposefully changed to reduce or eliminate specific exhaust constituents and, thereby, to have a positive impact on human health. In recognition of this difference (evaluating specific chemicals vs. evaluating complex and evolving mixtures), this document has emphasized in detail the remarkable changes in diesel technology and the related changes in exhaust constituent emissions.

In IARC's 1988 assessment of the complex mixture "diesel engine exhaust," the exposure section of Monograph 46 (IARC, 1989) focused on diesel exhaust particulate (DEP), the EC

particles and associated hydrocarbons viewed as the characteristic component of TDE. This was seen as appropriate since DEP, the primary focus of diesel exhaust hazard assessments, also served as an effective marker of exposure to TDE in each of the three biological approaches to hazard evaluation. Specifically, DEP (or Respirable Elemental Carbon (REC) or engine-related PM, as surrogates), served as the preferred exposure marker for conducting epidemiological studies and of exposure in controlled laboratory animal studies with diluted engine exhaust. Indeed, even today, no suitable alternative to those markers has been identified for epidemiological studies. And cellular or tissue assays or mechanistic studies also have frequently used concentrations of DEP, REC or PM as a measure of the administered dose. In other cases, strong organic solvent extracts of DEP were applied to cells or tissues and the quantities used and results obtained were extrapolated back to engine emissions of DEP.

Broad environmental concerns and focus on DEP as a potential health hazard in diesel exhaust led to stringent regulatory emission standards targeting reductions in PM along with NO_x and unburned hydrocarbons. As a result, DEP has been reduced by up to four orders of magnitude and the chemical characteristics of the particulate contained in NTDE are very different from TDE. Furthermore, as the DEP content of diluted exhaust has been reduced, the importance of characterizing other constituents such as NO₂ in animal and other exposure studies has become apparent.

In the 1970s and 1980s, when describing diesel engine exhaust in the context of its various biological assays, it was frequently considered sufficient to simply state that the studied exposures were to diesel exhaust or DEP. It was rare for investigators to note the characteristics of the fuel used (such as sulfur content), the specific characteristics of the engine, the duty cycle on which the engine operated, or details of how samples were collected for chemical analysis or use in bioassays. The situation began to change in the 1990s and, by the turn of the century, an appreciation began to develop of the important role that all of the foregoing parameters can play in influencing engine emissions and their potential hazard.

The approach used in the ACES program, with its very detailed characterization of the emissions from the four studied engines (each compliant with U.S. EPA 2007 emission standards) and also the very detailed characterization of the exposure atmospheres for the animal studies, has set a new technical standard for the assessment of diesel engine emissions and their potential health impact. It is now apparent that any studies (whether epidemiological, toxicological or mechanistic) of a hazard potentially associated with diesel exhaust should be carefully linked back to a complete description of the diesel technology at

issue. Such a description should include the engine (year of manufacture, engine displacement, any special characteristics), the duty cycle (preferably a variable load cycle specified by a national or international agency or a series of such cycles), the fuel quality (especially sulfur content), the presence or absence of exhaust aftertreatment systems (wall flow diesel exhaust particulate filters and oxidation catalysts), the exhaust dilution systems (dilution ratio), and the emissions sampling methodologies. The goal is to ensure that any emissions sampling or characterization that is undertaken is sufficiently described so that it can be validated and replicated according to rigorous scientific principles. How the emissions were generated, sampled and analyzed is critically important for interpreting the results of all studies, particularly the wide variety of available laboratory studies from a wide variety of diesel engines.

As shown in the ACES study, it is no longer sufficient to consider all diesel engine exhaust as though it were part of a single mixture, nor is it appropriate to evaluate the potential health responses to all diesel engine exhaust as though it was all the same or all representative of a uniform and static diesel technology. To the contrary, great care should be taken to note the varying attributes of engine and aftertreatment technologies, duty cycle, fuel composition and ambient conditions, and specific recognition should be given to the significant uncertainty that those varying attributes introduce into the interpretation of exposures and related effects. It is especially clear that this discipline is important to ensure the integrity of future studies.

The information reviewed in this document in combination with the material in IARC Monograph Vol. 46 (1989) provides a sound basis for separately considering the carcinogenic hazards of diesel engine exhaust for three different stages of technology development. The first stage is the period of essentially unregulated emissions, what we have termed TDE. That stage of emissions is described in IARC Monograph 46 and is the subject of all epidemiological studies reported to date. This fact is depicted graphically in **Figure 36** which shows the relevant potential exposure periods for each of the key diesel epidemiology studies compared to the start of particulate regulation – all exposure periods fall into the time of “unregulated particulate”.

Figure 36: Relevant exposure times of epidemiological studies published to date compared to time of first particulate emission regulations. All studies fall into the unregulated time period.

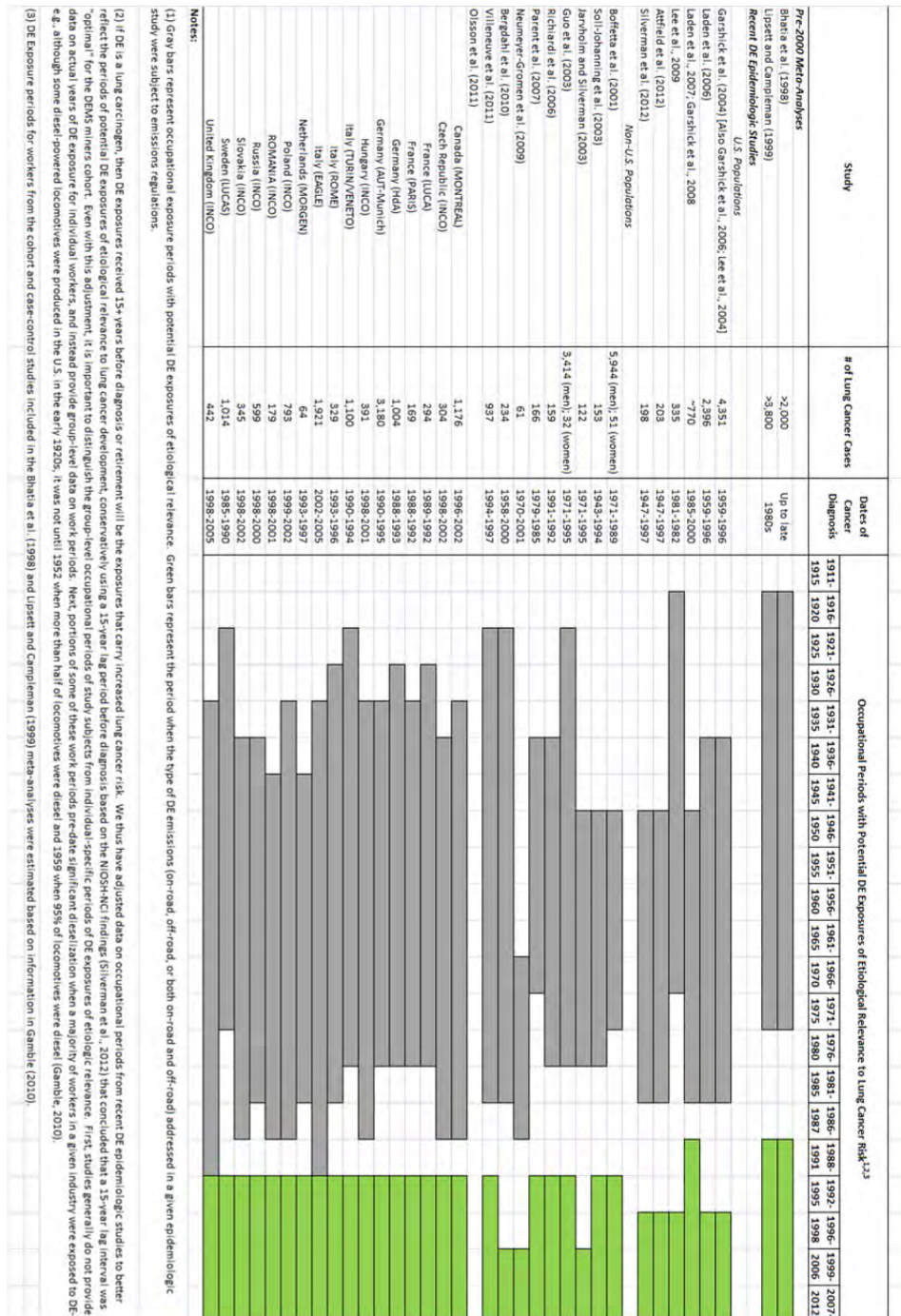

The second stage is a “transitional” phase characterized by the introduction of substantial evolutionary advances in technology, including the use of lower sulfur content fuel and a growing array of in-cylinder emission controls. The third stage is new technology diesel engines, equipped with wall-flow DPFs and DOCs and operating on ULSD.

It is important that there be a separate exposure characterization and assessment of the related evidence of carcinogenic hazard for each of the three stages of technology development. It is also important not simply to view the emissions from these three stages of technological development as being analogous to a high, medium and low level exposure to a specific chemical. Such an approach would fail to recognize the significant differences in the hazard potential of NTDE as compared to TDE or transitional engine exhaust emissions. IARC's recognition of the fundamental differences in cancer hazard potential will provide guidance to national governments and others as they develop strategies for encouraging the development and deployment of new, hazard-reducing technologies, such as are exemplified by new technology diesel engines.

13.0 REFERENCES

1. Attfield, M.D., Schleiff, P. L., Lubin, J.H., et al. (2012). The Diesel Exhaust in Miners Study: A Cohort Mortality Study With Emphasis on Lung Cancer. *J Natl. Cancer Inst* 104:1–15 (2012).
2. Ayala, A., Kado, N.Y., Okamoto, R.A., Holmen, B.A., Kuzmicky, P.A., Kobayashi, R., and Stiglitz, K.E. (2002). Diesel and CNG heavy-duty transit bus emissions over multiple driving schedules: Regulated pollutants and project overview, SAE Paper 2002-01-1722, Warrendale, PA.
3. Ayala, A., Gebel, M.E., Okamoto, R.A., Rieger, P.L., Kado, N.Y., Cotter, C., and Verma, N. (2003). Oxidation catalyst effect on CNG transit bus emissions, SAE Paper 2003-01-1900, Warrendale, PA.
4. Barone, T.L., Storey, J.M. and Norberto D. (2010). An Analysis of field-aged diesel particulate filter performance: particle emissions before, during and after regeneration. *J. Air Waste Manag. Assoc.* 2010:60:968-976
5. Bauner, D., Laestadius, S., and Iida, N. (2009). Evolving technological systems for diesel engine emission control: balancing GHG and local emissions. *Clean Tech. Environ Policy* 11, 339-365 (2009).
6. Biswas, S., Hu, S., Verma, V., Herner, J.D., Robertson, W.H., Ayala, A., and Sioutas, C. (2008). Physical properties of particulate matter (PM) from late model heavy-duty diesel vehicles operating with advanced PM and NOx emission control technologies, *Atmos. Environ.*, 42, 5622-5634 (2008).
7. Biswas, S., Verma, V., Schauer, J.J., and Sioputas, C. (2009). Chemical speciation of PM emissions from heavy-duty vehicles equipped with diesel particulate filter (DPF) and selective catalytic reduction (SCR) retrofits, *Atmos. Environ.*, 43, 1917-1925.
8. Bosteels, D., May, J., Karlsson, H., and de Serves, C. (2006). 'Regulated' and 'Non-regulated' emissions from modern european passenger cars, SAE Paper 2006-01-1516, Warrendale, PA.
9. CARB (1998a). Resolution 98-3 5 on Particulate Emissions from Diesel Engines, Agenda Item No.: 98-8-1 (August 27, 1998).

10. CARB (1998b). Report to the Air Resources Board on the Proposed Identification of Diesel Exhaust as a Toxic Air Contaminant, Exposure Assessment, (Part A), Health Risk Assessment for Diesel Exhaust, Office of Environmental Health Hazard Assessment, California Environmental Protection Agency.
11. CARB (1998c). Health Risk Assessment for Diesel Exhaust; Proposed Identification of Diesel Exhaust as a Toxic Air Contaminant (Part B). Health risk assessment for diesel exhaust. Office of Environmental Health Hazard Assessment, California Environmental Protection Agency, Sacramento, CA.
12. CARB (1998d). Scientific Review Panel Findings for the Proposed Identification of Diesel Exhaust as a Toxic Air Contaminant Report, adopted April 22, 1998. Air Resources Board, California Environmental Protection Agency, May 27, 1998. Available at: <http://www.arb.ca.gov/srp/findings/4-ww-98.pdf> (Accessed 1/29/2012).
13. Charlton, S., Dollmeyer, T., and Grana, T. (2010). Meeting the US heavy-duty EPA 2010 Standards and providing increased value for the customer. *SAE Int. J. Commer. Veh.* 3(1), 101-110 (2010).
14. Clark, N.N., Jarrett, R.P., and Atkinson, C.M. (1999). Field measurement of particulate matter emissions, carbon monoxide, and exhaust opacity from heavy-duty diesel vehicles. *J. Air & Waste Management Assoc.* 49, 75-84 (1999).
15. Clark, N.N., et al. (2001). Evaluation of Methods for Determining Continuous Particulate Matter from Transient Testing of Heavy-Duty Diesel Engines, SAE Paper 2001-01-3575, Warrendale, PA.
16. Clark, N.N., Kern, J., Atkinson, C., and Nine, R. (2002). Factors Affecting Heavy-Duty Diesel Vehicle Emissions. *Journal of the Air and Waste Management Association*, 52:1, 84-94 (2002).
17. Clark, N.N., M. Gautam, W.S. Wayne, G.J. Thompson, R.D. Nine, D.W. Lyons, T. Buffamonte, and S. Xu (2006). Regulated Emissions from Heavy-Duty Diesel Trucks Operating in the South Coast Air Basin, SAE Paper 2006-01-3395, Warrendale, PA.
18. Clark, N.N., Zhen, F., Bedick, Gautam, M., Wayne, W., Thompson, G., and Lyons, D. (2007). Creation of the 16-hour engine test schedule from the heavy- heavy-duty diesel engine test schedule. CRC Report: ACES-1-a. Coordinating Research Council, Alpharetta, GA. Available at <http://www.crcac.org/publications/emissions/index.html>. Accessed January 10, 2011.

19. Clark, N.N. (2012). Exhaust Particle emissions. International Commission on Occupational Health (ICOH) 2012. Special Session 118.1, Exposure assessment in epidemiologic studies of diesel exhaust and lung cancer. March 2012.
20. Coble, J.B., Stewart, P.A., Vermeulen, R., et al. (2010). The diesel exhaust in miners study: II. Exposure monitoring surveys and development of exposure groups. *Ann. Occup. Hyg.* 54(7), 747-761 (2010).
21. Colucci, J.M. (2004). Fuel quality – An essential element in vehicle emission control. ICEF 2004-982. Proceedings of ICEF 04: ASME Internal Combustion Engine Division 2004 Fall Conference, Long Beach, CA, USA, October 24-27, 2004, pgs 1-16.
22. Cummins, Clessie L. (1967). *My Days with the Diesel, The memoirs of Clessie L. Cummins, father of the highway diesel*, Chilton.
23. Cummins, C. Lyle, Jr. (1993). Diesel's Engine. Volume One. From Conception to 1918, Carnot Press, ISBN 0917308034.
24. Dollmeyer, T.A., Vittorio, D.A., Grana, T.A., Katzenmeyer, J.R., and Charlton, S.J. (2007). Meeting the US 2007 heavy-duty diesel emission standards – designing for the customer. SAE Paper 2007-01-4170, Warrendale, PA.
25. Gautam, M., Kappanna, H., John, B., Wayne, W.S, Carder, D., Osinuga, A., Kreeb, B., Paris, H., Graham, L., Tadrous, T., Brown, K. (2005). Reduction and characterization of exhaust emissions from a catalyzed trap-equipped natural gas fueled transit bus, Proceedings of the 15th CRC On-Road Vehicle Emissions Workshop, San Diego, CA, April 4-7, 2005.
26. Gertler, A., Gillies, J., Pierson, W., Rogers, C., Sagebiel, J., Abu-Allaban, M., Coulombe, W., Tamay, L., and Cahill, T. (2002). Real-World Particulate Matter and Gaseous Emissions from Motor Vehicles in a Highway Tunnel. Health Effects Institute Research Report No. 107.
27. Grahame, T.J. and Schlesinger, R.B. (2005). Evaluating the health risk from secondary sulfates in eastern North American regional ambient air particulate matter. *Inhalation Toxicology*, 17(1), 15-27 (2005).
28. Grose, M., Sakurai, H., Savstrom, J., Solzenburg, M.R., Watts, W.F., Jr., Morgan, C.G., Murray, I.P., Twigg, M.V., Kittelson, D.B., and McMurry, P.H. (2006). Chemical

and physical properties of ultrafine diesel exhaust particles sampled downstream of a catalytic trap, *Environ. Sci. Tech.* 40, 5502-5507 (2006).

29. Haney, R., Saseen, G., (2000) Estimation of diesel particulate concentrations in underground mines. *Mining Engineer.* 52: 60-64. April 2000
30. HEI (1999a). Diesel Epidemiology Expert Panel
31. HEI (2002a). Diesel Epidemiology Work Group Special Report
32. HEI (2002b). Improving Estimates of Diesel and Other Emissions for Epidemiologic Studies. Communication 10, Proceedings of an HEI Workshop. Baltimore, MD, December 4-6, 2002.
33. Herner, J.D., Hu, S., Robertson, W.H., Huai, T., Collins, J.F., Dwyer, H., and Ayala, A. (2009). Effect of advanced aftertreatment for PM and NO_x control on heavy-duty diesel truck emission. *Environ. Sci. Tech.* 43(15), 5928-5933 (2009).
34. Herner, J.D., Hu, S., Robertson, W.H., Huai, T., Chang, M.-C.O., Rieger, P., and Ayala, A. (2011). Effect of advanced aftertreatment for PM and NO_x reduction on heavy-duty diesel engine ultrafine particle emissions, *Environ. Sci. Tech.* 45(24), 2413-2419 (2011).
35. Hesterberg, T.W., Bunn, W.B., McClellan, R.O., Hart, G.A., and Lapin, C.A. (2005). Carcinogenicity Studies of Diesel Engine Exhausts in Laboratory Animals: A Summary of Past Studies and a Discussion of Future Research Needs Critical Reviews in *Toxicology*, 35:379–41 (2005).
36. Hesterberg, T.W., Bunn, W.B., Chase, G.R., Valberg, P.A., Slavin, T.J., Lapin, C.A., and Hart, G.A. (2006). A critical assessment of studies on the carcinogenic potential of diesel exhaust. *Critical Rev. Toxicol.* 36, 727-776 (2006).
37. Hesterberg, T.W., Lapin, C.A., and Bunn, W.B. (2008). A comparison of emissions from vehicles fueled with diesel or compressed natural gas. *Environ. Sci. Technol.* 42(17), 6437-6445 (2008).
38. Hesterberg, T.W., Long, C.M., Sax, S.N., Lapin, C.A., McClellan, R.O., Bunn, W.B., and Valberg, P.A. (2011). Particulate matter in new technology diesel exhaust (NTDE) is quantitatively and qualitatively very different from that found in traditional diesel exhaust (TDE), *J. Air Waste Management Assn.* 61, 894-913 (2011).

39. Hesterberg, T.W., Long, C.M., Bunn, W.B., Lapin, C.A., McClellan, R.O., and Valberg, P.A. (2012). Research and regulation of diesel exhaust emissions and health effects; historical overview focused on lung cancer risk (in press, 2012).
40. Holmén, B.A. and Ayala, A. (2002). Ultrafine PM emissions from natural gas, oxidation-catalyst diesel, and particle-trap diesel heavy-duty transit buses, *Environ. Science & Tech.* 36/23: 5041-50 (2002).
41. Holmén, B.A. and Qu, Y. (2004). Uncertainty in particle number modal analysis during transient operation of compressed natural gas, diesel, and trap-equipped diesel transit buses. *Environ. Sci. Tech.* 38(8), 2413-2423 (2004).
42. IARC (1989). Diesel and Gasoline Engine Exhausts and Some Nitroarenes: World Health Organization, International Agency for Research on Cancer, Monograph Vol. 46, Lyon, France (1989).
43. IARC (2012a). IARC Monographs on the Evaluation of Carcinogenic Risks to Humans. Vol. 100E, A Review of Human Carcinogens, Personal Habits and Indoor Combustion, International Agency for Research on Cancer, Lyon, France. Available at: <http://monographs.iarc.fr/ENG/Classification/index.php> (last accessed 2/12/2012).
44. IARC (2012b). IARC Monographs on the Evaluation of Carcinogenic Risks to Humans. Vol. 100F, Chemical Agents and Related Occupations. Announcement of June 5-12, 2012 Meeting, International Agency for Research on Cancer, Lyon, France. Available at: <http://monographs.iarc.fr/ENG/Classification/index.php> (last accessed 2/12/2012).
45. Johnson, T.V. (2010). Diesel emissions in review. SAE Paper 2010-01-0301, Warrendale, PA.
46. Johnson, T.V. (2011). Diesel emissions in review. SAE Paper 2011-01-0304, Warrendale, PA.
47. Jones, A.M., Harrison, R.M., Barratt, B., and Fuller, G. (2012). A large reduction in airborne particle number concentrations at the time of the introduction of "sulfur free" diesel and the London low emission zone, *Atmosph. Environ.* 50, 129-138 (2012).
48. Kado, N.Y., Okamoto, R.A., et al. (2005). Emissions of toxic pollutants from compressed natural gas and low sulfur diesel-fueled heavy-duty transit buses over multiple driving cycles, *Environ. Sci. Tech.* 39(19), 7638-7649 (2005).

49. Khalek, I.A., Boughner, T.L., and Merritt, P.M. (2009). Phase 1 of the Advanced Collaborative Emissions Study. CRC Report: ACES Phase 1. Coordinating Research Council, Alpharetta, GA, available at <http://www.crcao.org/publications/emissions/index.html> .
50. Khalek, I.A., Boughner, T.L. Merritt, P.M., and Zielinska, B. (2011). Regulated and unregulated emissions from highway heavy-duty diesel engines complying with U.S. Environmental Protection Agency 2007 Emissions Standards, *J. Air & Waste Management Assoc.* 61, 427-442 (2011).
51. Kittelson, D.B., Watts, W.F., Johnson, J.P., Rowntree, C., Payne, M., Goodier, S., Warrens, C., Preston, H., Zink, U., Ortiz, M., et al. (2006a). On-road evaluation of two diesel exhaust aftertreatment devices, *Aerosol Sci.* 37, 1140-1151 (2006).
52. Kittelson, D.B., Watts, W.F., Johnson, J.P., Rowntree, C.J., Goodier, S.P., Payne, M.J., Preston, W.H., Warrens, C.P., Ortiz, M., Zink, U., Goersmann, C., Twigg, M.V., and Walker, A.P. (2006b). Driving down on-highway particulate emissions, SAE Paper 2006-01-0916, Warrendale, PA.
53. Lanni, T., Frank, B.P., Rosenblatt, D., and Lowell, D. (2003). Performance and emissions evaluation of compressed natural gas and clean diesel buses at New York City's Metropolitan Transit Authority, SAE Paper 2003-01-0300, Warrendale, PA.
54. LeTavec, C., Uihlein, J., Hallstrom, K., Vertin, K., Chandler, K., Chatterjee, S., Coburn, T., Wayne, S., Clark, N., Gautam, M., Thompson, G., and Lyons, D. (2002). Year-long evaluation of trucks and buses equipped with passive diesel particulate filters, SAE Paper 2002-01-0433, Warrendale, PA.
55. Li, J., Currier, N., Yezerets, A., Chen, H., and Hess, H. (2009). Evaluation of Spatially Resolved Performance of NO_x Adsorber Catalysts, SAE Paper 2009-01-0275, Warrendale, PA.
56. Liu, Z.G., Vasys, V.N., and Kittelson, D.B. (2007). Nuclei-mode particulate emissions and their response to fuel sulfur content and primary dilution during transient operations of old and modern diesel engines. *Environ. Sci. Tech.* 41, 6479-6483 (2007).
57. Liu, Z.G., Berg, D.R., and Schauer, J.J. (2008a). Comparative analysis on the effects of diesel particulate filter and selective catalytic reduction systems on a wide

- spectrum of chemical species emissions, *Environ. Sci. Tech.* 42(16), 6080-6085 (2008).
58. Liu, Z.G., Berg, D.R., and Schauer, J.J. (2008b). Detailed effects of diesel particulate filter on the reduction of chemical species emissions, *SAE Intl. J. Fuels Lubr.* 1(1): 184-191 (2008).
59. Liu, Z.G., Berg, D., Swor, T., and Schauer, J. (2009a). Comparison of strategies for the measurement of mass emissions from diesel engines emitting ultra-low levels of particulate matter, *Aerosol Sci. Tech.* 43(11), 1142-1152 (2009).
60. Liu, Z.G., Berg, D., Swor, T., and Schauer, J. (2009b). A Study on the emissions of chemical species from heavy-duty diesel engines and the effects of modern aftertreatment technology, SAE Paper 2009-01-1084, Warrendale, PA.
61. Liu, Z.G., Berg, D.R., Vasys, V.N., Dettmann, M.E., Zielinska, B., and Schauer, J.J. (2010). Analysis of C₁, C₂, and C₁₀ through C₃₃ particle-phase and semi-volatile organic compound emissions from heavy-duty diesel engines, *Atmos. Environ.* 44, 1108-1115 (2010).
62. Liu, Z.G., Ottinger, N.A., Wall, J.C. and Barge, P. (2011a). Measurement of Dioxin and Furan Emissions during Transient and Multi-Mode Engine Operation, SAE Paper 2011-01-1158, Warrendale, PA.
63. Liu, Z.G., Wall, J.C., Barge, P., Dettman, M.E., and Ottinger, N.A. (2011b). Investigation of PCCD/F Emissions from Mobile Source Diesel Engines: Impact of Copper Zeolite SCR Catalysts and Exhaust Aftertreatment Configurations, *Environ. Sci. Technol.*, 45, 2965-2972 (2011).
64. Martin, W.T. (2012). Cummins Inc., Private communication, February, 2012.
65. Mauderly, J.L. and McDonald J.D. (2012). Advanced Collaborative Emissions Study (ACES) Phase 3A: Characterization of U.S. 2007- Compliant Diesel Engine and Exposure System Operation. Communication 17. Health Effects Institute, Boston, MA (in press).
66. McClellan, R.O., Hesterberg, T.W., Wall, J.C. (2012). Evaluation of Carcinogenic Hazard of Diesel Engine Exhaust Needs to Consider Revolutionary Changes in Diesel Technology, *Regul. Toxicol. Pharmacol.* (in press, May 2012).

67. McKain, D., Wayne, S., and Clark, N. (2012). Relationship between Carbon Monoxide and Particulate Matter Levels across a Range of Engine Technologies, SAE Paper 2012-01-1346, Warrendale, PA.
68. McCormick, R.L., Graboski, M.S., Alleman, T., Herring, A.M., and Nelson, P. (1999). In-use emissions from natural gas fueled heavy-duty vehicles, SAE Paper 1999-01-1507, Warrendale, PA.
69. Northeast Advanced Vehicle Consortium (M.J. Bradley & Associates, Inc, West Virginia University) (2000). Hybrid-electric drive heavy-duty vehicle testing project: Final emissions report, NAVC1098-PG009837, Northeast Advanced Vehicle Consortium (NAVC) and Defense Advanced Research Projects Agency (DARPA), Boston, MA.
70. Norton, P., Frailey, M., Clark, N., Lyons, D., Gautam, M., Addy, J., and Beck, N. (1999). Chassis dynamometer emission measurements from trucks and buses using dual-fuel natural gas engines, SAE Paper 1999-01-3525, Warrendale, PA.
71. O'Keefe, R. (2012). Air quality Standards under Active Review Worldwide, and How HEI is Contributing, Presentation to the Health Effects Institute Annual Meeting, Chicago, IL, April 2012.
72. Pakbin, P., Ning, Z., Schauer, J.J., and Sioutas, C. (2009). Characterization of particle bound organic carbon from diesel vehicles equipped with advanced emission control technologies, Environ. Sci. Tech. 43, 4679-4686 (2009).
73. Reiss, R., Anderson, E.L., Cross, C.E., Hidy, G., Hoel, D., McClellan, R., and Moolgavkar, S. (2007). Evidence of health impacts of sulfate-and nitrate-containing particles in ambient air, Inhal. Toxicol. 19, 419-449 (2007).
74. Rose, K., Grigoratos, T., Samara, C. (2010). Impact of FAME in Diesel on Particle Emissions from Euro 4-compliant Light-duty Vehicles, 14th ETH Conference on Combustion Generated Nanoparticles, August 1-4, 2010.
75. Schlesinger, R.B. and Cassee, F. (2003). Atmospheric secondary inorganic particulate matter: The toxicological perspective as a basis for health effects risk assessment, Inhal. Toxicol. 15, 197-235 (2003).

76. Schlesinger, R.B. (2007). The health impact of common inorganic components of fine particulate matter (PM_{2.5}) in ambient air: A critical review, *Inhal. Toxicol.* 19, 811-832 (2007).
77. Silverman, D.T., Samanic, C.M., Lubin, J.H. et al. (2012). The Diesel Exhaust in Miners Study: A Nested Case–Control Study of Lung Cancer and Diesel Exhaust. *J Natl. Cancer Inst.* 104:1–14 (2012).
78. Stewart, P.A., Coble, J.B., Vermeulen, R., et al. (2010). The diesel exhaust in miners study: I. Overview of the exposure assessment process. *Ann. Occup. Hyg.* 54(7), 728-746 (2010).
79. Stewart, P.A., Coble, J.B., Vermeulen, R., et al. (2012). The diesel exhaust in miners study: V. Evaluation of the exposure assessment methods. *Ann Occup Hyg*, pp 1-12 (Open Access Article) doi:10.1093/annhyg/mes020.
80. Tobias, H.J., Beving, D.E., and Ziemann, P.J. (2001). Chemical analysis of diesel engine nanoparticles using a nano-DMA/Thermal Desorption Particle Beam Mass Spectrometer, *Environ. Sci. Tech.* 35, 2233-2243 (2001).
81. Tschöcke, H., Graf, A., Stein, J., Krüger, M., Schaller, J., Breuer, N., Engeljehring, K., and Schinler, W. (2010). Diesel engine exhaust emissions. In: *Handbook of Diesel Engines* (Mollenhauer, K., Tschöcke, H., Eds.), Springer-Verlag, Berlin Heidelberg, ISBN 978-3-540-89082-9, pp 417-486 (2010).
82. U.S. EPA (2002). Health Assessment Document for Diesel Engine Exhaust, EPA/600/8-90/057F, Washington, DC: U.S. Environmental Protection Agency, Office of Research and Development, National Center for Environmental Assessment.
83. Vermeulen, R., Coble, J.B., Yereb, D., Lubin, J.H., Blair, A., Portengen, L., Stewart, P.A., Attfield, M., and Silverman, D.T. (2010a). The diesel exhaust in miners study: III. Interrelations between respirable elemental carbon and gaseous and particulate components of diesel exhaust derived from area sampling in underground non-metal mining facilities, *Ann. Occup. Hyg.* 54(7), 762-773 (2010).
84. Vermeulen, R., Coble, J.B., Lubin, J.H., Portengen, L., Blair, A., Stewart, P.A., Attfield, M.D., and Silverman, D.T. (2010b). The diesel exhaust in miners study: IV. Estimating historical exposures to diesel exhaust in underground non-metal mining facilities, *Ann. Occup. Hyg.* 54(7), 774-788 (2010).

85. Wahlin, P., Palmgren, F., Van Dingenen, R., and Raes, F. (2001). Pronounced decrease of ambient particle number emissions from diesel traffic in Denmark after reduction of the sulfur content in diesel fuel, *Atmosphere. Environ.* 35, 3549-3552 (2001).
86. Wall, J. and Hoekman, S. (1984). Fuel Composition Effects on Heavy-Duty Diesel Particulate Emissions, SAE Paper 841364, Warrendale, PA.
87. Wall, J. and McDonald, J. (2012). New Technology Diesel Engines: Emission Control and Animal Toxicology Studies. California Air Resources Board Chairman's Research Seminar Series, February 28, 2012.
<http://www.arb.ca.gov/research/seminars/wall/wall.pdf>
88. Walsh, M. (2012). Global Trends in Heavy Duty Diesel Emissions Controls: Modern Diesels Are Much Cleaner Than In The Past And The New Technology Is Spreading Around The World. A Report prepared for the Engine Manufacturers Association. (2012).
89. Wang, W.G., Clark, N.N., Lyons, D.W., Yang, R.M., Gautam, M., Bata, R.M., and Loth, J.L. (1997). Emissions comparisons from alternative fuel buses and diesel buses with a chassis dynamometer testing facility, *Environ. Sci.Tech.* 35, 3132-3137 (1997).
90. Xu, S., Clark, N.N., Gautam, M., and Wayne, W.S. (2005). Comparison of Heavy-Duty Diesel Particulate Matter Measurement: TEOM and Traditional Filter, SAE Paper 2005-01-2153, Warrendale, PA.
91. Yanowitz J, McCormick RL, Graboski MS. (2000) In-use emissions from heavy-duty vehicle emissions. *Environ Sci Technol*; Vol. 34, No. 5: 729–40
92. Zheng, Z., Durbin, T., Karavakalis, G., Johnson, K., Chaudhary, A., Cocker, D., Herner, J., Robertson, W., Huai, T., Ayala, A., Kittelson, D., and Jung, H. (2012). Nature of Sub-23-nm Particles Downstream of the European Particle Measurement Programme (PMP)-Compliant System: A Real-Time Data Perspective. *Aerosol Science and Technology*, online April 23, 2012.

14.0 ABBREVIATIONS AND OTHER TERMS

AFR	Air/Fuel Ratio
AC50/80	Acceleration cruise 50/80 km/hr driving cycle
ACEA	European Automobile Manufacturers Association
ACES	Advanced Collaborative Emissions Study
AHR	Aryl hydrocarbon hydroxyl receptor
Al ₂ O ₃	Aluminum oxide
API	American Petroleum Institute
CARB	California Air Resources Board; Air Resources Board
CRC	Coordinating Research Council
Ba(NO ₃) ₂	Barium nitrate
BaCO ₃	Barium carbonate
bhp-hr	brake horsepower-hour
°C	degrees Celsius
CAA	Clean Air Act (US)
CCC	Close-coupled catalyst
CDPF	Catalyzed diesel particulate filter
CFR	Code of Federal Regulations (US)
CNG	Compressed natural gas
CO	Carbon monoxide
CO ₂	Carbon dioxide
CONCAWE	The oil companies' European association for environment, safety, and health in refining and distribution
Cu	Copper
CuZ	Copper zeolite
DE	Diesel exhaust

DEP	Diesel exhaust particulate
DeNOx	Selective Catalytic Reduction for NOx removal
DEMS	Diesel Exhaust Miners Study
DeSOx	Sulfur removal from a Lean NOx Trap by periodic high temperature excursions under reducing conditions
DOC	Diesel Oxidation Catalyst
DOE	Department of Energy (US)
DPF	Diesel Particulate Filter
EC	Elemental carbon
EGR	Exhaust Gas Recirculation
EMA	Truck and Engine Manufacturers Association
EPA	Environmental Protection Agency (US)
EU	European Union
Euro I-VI	European emissions regulations for heavy-duty diesel engines
FBC	Fuel-borne catalyst
FEL	Family emission limit
FTP	Federal Test Procedure
g/bhp-hr	gram/brake-horsepower-hour
GDP	Gross Domestic Product
GNMD	Geometric number mean diameter
H ₂	Hydrogen (molecular)
H ₂ O	Water
HAD	Health Assessment Document
HAP	Hazardous Air Pollutant
HEPA	High Efficiency Particulate Filter
HC	Hydrocarbon

HCCI	Homogeneous Charge Compression Ignition
HD/HDV	Heavy duty/Heavy-duty vehicle
HDD	Heavy-duty diesel
HEI	Health Effects Institute (US)
HHDE	Heavy heavy-duty diesel engine
HHDDT	Heavy heavy duty diesel truck
HDOH	Heavy-duty on-highway
HNO ₃	Nitric acid
IARC	International Agency for Research on Cancer
ICOH	International Conference on Occupational Health
IEA	International Energy Agency
ICCT	International Council of Clean Transportation
LD/LDV	Light duty/Light-duty vehicle
LNC	Lean NOx Catalyst
LNT	Lean NOx Trap
LRRI	Lovelace Respiratory Research Institute (US)
LTC	Low Temperature Combustion
MECA	Manufacturers of Emission Controls Association
mg	Milligram
MGE	Modern Gasoline Exhaust
MSHA	Mine Safety and Health Administration (U.S.)
nitro-PAH	Nitrogen-containing polycyclic aromatic hydrocarbon
N ₂	Nitrogen (molecular)
NCI	National Cancer Institute (US)
NEDC	New European Driving Cycle
NH ₃	Ammonia
NIOSH	National Institute of Occupational Safety and Health

	(US)
NMHC	Non-methane hydrocarbon
NO	Nitrogen oxide
NO ₂	Nitrogen dioxide
NO ₃	Nitrate
NO _x	Oxides of nitrogen
NRDC	Natural Resources Defense Council
NTDE	New Technology Diesel Exhaust
NTP	National Toxicology Program (US)
O ₂	Oxygen (molecular)
OC	Organic Carbon Oxidation Catalyst
oxy-PAH	Oxygen-containing polycyclic aromatic hydrocarbon
PAH	Polycyclic Aromatic Hydrocarbon
Pd	Palladium
PM	Particulate Matter
PMP	Particulate Measurement Programme
PN	Particle Number
ppm	parts per million
Pt	Platinum
REC	Respirable Elemental Carbon
Rh	Rhodium
S	Sulfur
SCR	Selective Catalytic Reduction
SO ₂	Sulfur dioxide
SO ₃	Sulfur trioxide
SO ₄	Sulfate

SOF	Soluble Organic Fraction Semi-Volatile Organic Fraction
SVC	Semi-volatile Compounds
SwRI	Southwest Research Institute (US)
TAC	Toxic Air Contaminant
TDE	Traditional Diesel Exhaust
TEF	Toxic Equivalency Factor
TGE	Traditional Gasoline Exhaust
THC	Total Hydrocarbons
TWC	Three-way Catalyst
UAF	Upward Adjustment Factor (for emissions certification)
UDDS	Urban Dynamometer Driving Schedule
UN ECE	United Nations Economic Commission for Europe
ULSD	Ultra-low Sulfur Diesel (<15ppm S)
VOC	Volatile Organic Compound
V ₂ O ₅ /TiO ₂	Vanadium oxide/Titanium oxide
WHO	World Health Organization
WHTC	World Harmonised Test Cycle

15.0 ACKNOWLEDGEMENTS

The authors wish to acknowledge the contributions and support from the following industrial associations who participated in the 2012 IARC Review Stakeholder Group (IRSG):

- ▶ Alliance of Automobile Manufacturers (AAM, <http://www.autoalliance.org>)
- ▶ European Automobile Manufacturers Association (ACEA, <http://www.acea.be>)
- ▶ Association for Emissions Control by Catalyst (AECC, <http://www.aecc.be>)
- ▶ American Petroleum Institute (API, <http://www.api.org>)
- ▶ CONCAWE (The oil companies' European association for environment, health and safety in refining and distribution, <http://www.concawe.org>)
- ▶ Truck and Engine Manufacturers Association (EMA, <http://www.truckandenginemanufacturers.org>)
- ▶ International Petroleum Industry Environment Conservation Association (IPIECA, <http://www.ipieca.org>)
- ▶ Manufacturers of Emission Controls Association (MECA, <http://www.meca.org>)
- ▶ International Organization of Motor Vehicle Manufacturers (OICA, <http://www.oica.net>)

APPENDIX 1 EMISSION CONTROL TECHNOLOGIES FOR DIESEL ENGINES

1.0	Introduction.....	96
2.0	Approaches for Reducing Diesel Emissions.....	98
2.1	Engine Controls	98
2.2	Exhaust Controls.....	100
3.0	Substrate Technologies.....	103
4.0	Oxidation Catalysts.....	104
4.1	Diesel Oxidation Catalyst.....	104
4.2	Filter Regeneration Catalysts.....	105
4.3	Impact of Sulfur on Oxidation Catalysts	106
5.0	Diesel Particulate Filter.....	108
5.1	High Efficiency Filters	108
5.1.1	Operating Characteristics and Filter Regeneration.....	109
5.1.2	Filter Maintenance	111
5.2	Partial Flow Diesel Particulate Filters and “Flow-through” filters.....	112
5.3	Impacts of Sulfur of Particulate Filters	112
5.4	Closed Crankcase Ventilation	113
6.0	NOx Reduction Technologies	115
6.1	Exhaust Gas Recirculation (EGR).....	115
6.2	Selective Catalytic Reduction (SCR).....	117
6.2.1	Operating Characteristics and Control Capabilities.....	117
6.3	NOx Adsorber Catalysts	120
6.3.1	Operating Characteristics and Performance	120
6.3.2	Impact of Fuel Sulfur and Durability	122
6.3.3	Application of NOx Adsorber Technology.....	123
6.4	Lean NOx Catalysts	123
6.5	Combined LNT/SCR NOx Reduction Technologies.....	124
7.0	Effects of Diesel Fuel Composition on Vehicle Emissions.....	126
7.1	Effects of Oxygenates in Diesel Fuel on Vehicle Emissions	129
8.0	On-Board Diagnostic (Obd) Requirements.....	134
9.0	Conclusions.....	136
10.0	APPENDIX 1 References	137

1.0 INTRODUCTION

The need for the control of the pollutant emissions from gasoline and diesel engines has long been recognised. Legislation around the world limits the permissible emissions of carbon monoxide (CO), hydrocarbons (HC), oxides of nitrogen (NO_x) and particulate matter (PM). Exhaust emissions can be lowered somewhat by reducing engine-out emissions through improvements to the combustion process and fuel management, or by changes to the type of fuel or its composition, but emissions control systems – autocatalysts, adsorbers and particulate filters – in combination with good quality fuel, especially low sulfur content, and enhanced engine management - reduce emissions to very low levels. As well as their application in new vehicles and machinery, many emissions control systems can also be applied in retrofit installations to good effect.

Diesel engines provide important durability and fuel economy (and hence CO₂ emission) advantages for large heavy-duty trucks, buses, non-road mobile machinery (including rail locomotives and ships) and passenger cars. They are often the power plant of choice for heavy-duty applications and in Europe, more than 50% of the new cars sold each year are powered by a diesel engine. A range of technologies to control pollutant emissions from diesel engines is available, and to meet legislative requirements modern diesel engines use a combination of such systems, typically a diesel oxidation catalyst, a particulate filter, and a selective catalytic reduction (SCR) to control NO_x.

The emission control technologies discussed in this document represent state-of-the-art approaches that new vehicle manufacturers are using to meet existing and future emission regulations (**Figure A1-1** and **A1-2**).

Figure A1-1: Emissions regulations for heavy-duty diesel engines [1]

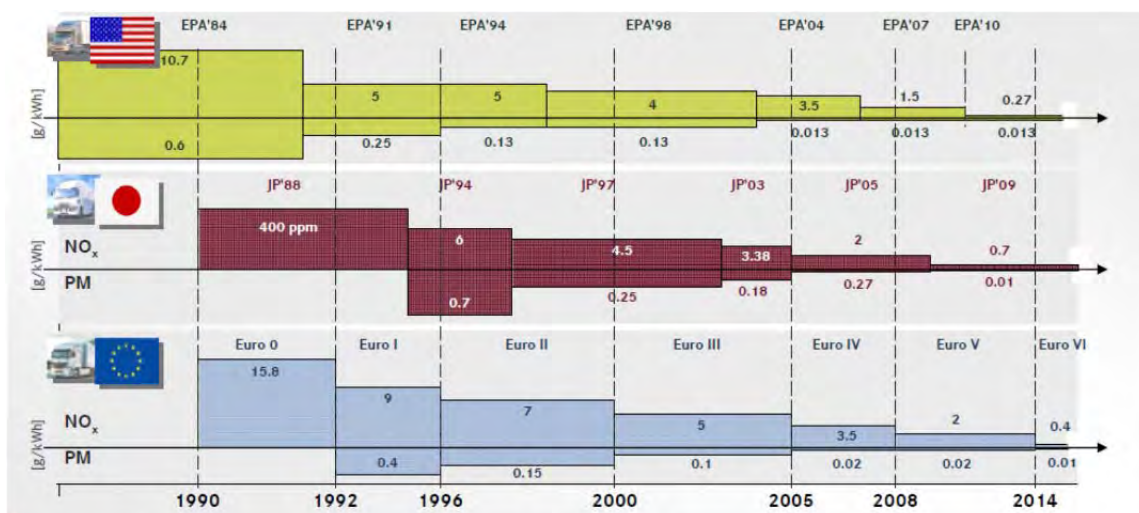
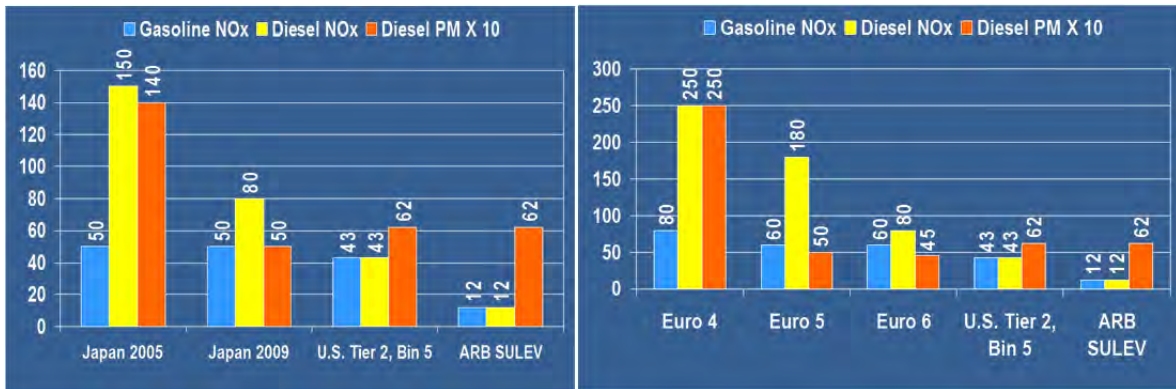

Figure A1-2: Emissions regulations for light-duty engines



2.0 APPROACHES FOR REDUCING DIESEL EMISSIONS

The technological feasibility of meeting the strict U.S. Tier 2 and Euro 4/5/6 standards for diesel passenger vehicles and the US 2007/2010 and Euro IV/V/VI on-highway diesel truck emission standards was predicated on having a low sulfur diesel fuel that was readily available. (The impact of diesel sulfur on individual emission control technologies will be discussed in each technology section.) The European Union Fuel Quality Directive [2] required diesel fuel and gasoline with a maximum sulfur content of 10 ppm to be available on a balanced geographical basis from January 2005, and all such fuels to meet this standard from January 2009. The U.S. EPA required the wide-scale availability of ultra-low sulfur diesel (ULSD) having <15 ppm sulfur in October 2006 in advance of the 2007 heavy-duty diesel on-road truck regulation. As detailed in the EPA rulemaking documents for the 2007/2010 heavy-duty on-road regulations [3], compliance with these regulations would require a systems engineering approach that combines the use of ULSD with advanced engines and advanced exhaust emission control technologies.

2.1 ENGINE CONTROLS

Engine manufacturers started as early as the late eighties to develop cleaner diesel engines by employing a number of strategies. These approaches include advanced common rail fuel injection, electronic engine controls, combustion chamber modifications, air boosting, improved air/fuel mixing, and reduced oil consumption. Achieving ultra-low exhaust emission targets requires a systems approach. Engine manufacturers are focusing on ways to control engine operation to reduce engine-out emissions as low as possible and reduce the burden on the exhaust emission control systems.

Approaches aimed at reducing cold-start emissions involve retarding the ignition timing to allow some hydrocarbons to pass through in the exhaust and light off the catalyst sooner. This approach can also be effective in generating sufficient exothermic heat over a catalyst to regenerate soot from a particulate filter as will be discussed in subsequent sections.

Variable valve timing (VVT) is being used to introduce some fraction of exhaust gas into the combustion process and reduce HC and NO_x emissions. Exhaust gas recirculation (EGR) is used to dilute intake air with some fraction of exhaust gas to lower the combustion temperatures resulting in lower engine-out NO_x emissions. This can come at the price of increasing PM in the exhaust, however.

Direct injection of fuel into the cylinders rather than port injection has allowed for better control of the air fuel ratio during combustion and resulted in better fuel utilization. Improved turbulence and mixing in the intake port of some low emission engines have resulted in fuel savings. Advanced diesel engines have benefited significantly from common rail fuel injection which allows for electronically controlled injection at very high pressures. Through the use of pilot and retarded injection strategies or in combination with injection rate shaping, clean diesels have achieved significant reductions in NO_x over conventional diesel injection such as pipe-line or unit injection. Common rail and electronic injection control is very effective in carefully controlling post injection of fuel making it suitable for use with emission control devices such as particulate filters, NO_x adsorbers and lean NO_x catalysts requiring brief periods of fuel rich exhaust to facilitate regeneration of the catalyst or filter.

Understanding and controlling the combustion process is the first step in reducing engine-out emissions and minimizing the burden on the emission control systems. This allows catalyst developers to design smaller, less costly exhaust controls. Engine design is an important part of controlling and facilitating the combustion process.

In diesel engines, controlling the combustion is the key approach to reducing engine out particulate emissions by optimizing the mixing between the fuel and air in the combustion chamber. Some common ways to increase mixing are through combustion chamber modifications to facilitate turbulent flow as well as fuel injector and injection port design to modify the spray pattern. Variable geometry turbocharging (VGT), which delivers variable quantities of pressurized air based on driving conditions, has been effective in reducing PM emissions by maintaining lean combustion in the engine. Reducing the compression ratios has been shown effective in lowering combustion temperatures and, in turn, NO_x emissions.

Some engine manufacturers have been able to achieve improvements to combustion during cold-start by making modifications to the design of intake air control valves resulting in a 40-50% reduction in HC emissions.

State-of-the-art developments in combustion engineering have led to significant reductions in engine-out emissions on experimental engines. These processes are known by many names and acronyms but they all fall into the general classification of low temperature combustion or pre-mixed homogeneous combustion processes, such as homogeneous charge compression ignition (HCCI), among others.

The conventional wisdom in diesel combustion has been that any change in engine operating parameters to reduce NO_x emissions results in an increase in particle emissions.

In general, higher combustion temperatures promote complete oxidation of the fuel, thus less soot, but also cause more formation of NO_x. Unlike traditional spark-ignited (SI) or compression-ignited (CI) engines, which have specified ignition points, HCCI combustion takes place spontaneously and homogeneously with many nucleated ignition points and therefore without flame propagation. This eliminates heterogeneous air/fuel mixture regions which result in soot particles. Low temperature combustion can be facilitated by the use of ultrafine injector orifice diameters in conjunction with lower excess oxygen content in the fuel mixture to achieve a more homogeneous distribution of the charge, thus reducing both NO_x and PM.

These combustion processes occur only within a limited range of the operating cycle, making control difficult under high speed/load and transient operation. For this reason, advanced multi-mode diesel engines combine HCCI operation at lower speeds to minimize PM and NO_x while reverting to conventional stratified charge combustion at high speed/load operation to ensure stable operation.

2.2 EXHAUST CONTROLS

This section provides a brief description of the available diesel exhaust control technologies, including descriptions of their operating characteristics, control capabilities and operating experience. More detail on each control technology is provided in subsequent sections.

The majority of hydrocarbon and carbon monoxide emissions from diesel engines that have exhaust catalysts occur during cold-start before the catalyst can achieve optimum operating temperatures. Engine and exhaust system manufacturers have working together with catalyst companies to develop ways to heat up the catalyst as quickly as possible. The greatest benefit came from the introduction of close-coupled catalysts (CCCs). This positioned the diesel oxidation catalyst (DOC) close to the exhaust manifold to allow rapid heating and therefore rapid oxidation of CO and hydrocarbons. The exothermic heat generated in the DOC by these oxidation reactions facilitates the rapid heat up of the downstream catalysts, such as diesel particulate filters, lean NO_x catalysts, and SCR catalysts.

A supporting technology that links engine controls and exhaust controls and has been used effectively by both engine and exhaust technology developers is thermal management. The beneficial impact on reducing cold-start emissions via thermal management has resulted from numerous improvements to the exhaust system components upstream of the DOC in order to retain as much heat as possible in the exhaust gases. Manufacturers have

developed ways to insulate the exhaust manifold and exhaust pipe. Attaching the DOC to a double-walled, stainless steel exhaust pipe containing an air gap within the tube walls is probably the most common thermal management strategy used today. This approach has been taken further by incorporating new inlet cone designs and modifications to the shape of the space in front of the close-coupled substrate. Thermal management between catalyst components in the diesel exhaust stream is also important to effectively regenerate the diesel particulate filter by retaining heat from the oxidation catalyst or auxiliary heat source when passive or active regeneration strategies are employed. Retaining enough heat downstream to regenerate a lean NO_x trap also requires thermal management and carefully engineered exhaust components.

A brief description of the major technologies employed in the reduction of pollutants from diesel exhaust is included below along with a range of conversion efficiencies that may be achieved. More detailed descriptions of their performance characteristics will be covered in subsequent sections of this appendix.

Diesel Oxidation Catalysts (DOCs) installed on a vehicle's exhaust system can reduce total PM typically by as much as 25 to over 50% by mass, under some conditions depending on the composition of the PM being emitted. Diesel oxidation catalysts can also reduce smoke emissions from older vehicles and virtually eliminate obnoxious odors associated with diesel exhaust. Oxidation catalysts can reduce more than 90 percent of the CO and HC emissions and more than 70 percent of the toxic hydrocarbon emissions in diesel exhaust.

Diesel Particulate Filters (DPFs) are installed on all new diesel-powered vehicles to meet the U.S. Tier 2 [4] and Euro 5 and 6 [5] light-duty standards and the U.S. 2007 heavy-duty on highway emission limits for PM. They are frequently used in meeting European EEV (enhanced environmentally friendly vehicle) emissions standards [6] and are expected to be used to meet Euro VI [7] requirements. DPFs can achieve up to, and in some cases, greater than a 90 percent reduction in PM. High efficiency filters are extremely effective in controlling the carbon fraction of the particulate, the portion of the particulate that some health experts believe may be the PM component of greatest concern and in controlling the number of ultrafine solid particles to meet the requirements of Euro 5/6/IV, with reduction efficiencies of some three orders of magnitude being achieved [8,9]. Particulate filters can be designed to also reduce toxic hydrocarbons emissions by over 90%. Catalytic exhaust control and particulate filter technologies have been shown to decrease the levels of PAH, nitro-PAH, and the mutagenic activity of diesel PM.

Exhaust Gas Recirculation (EGR) is being used on new light-and heavy-duty diesel vehicles as the primary method of reducing engine-out NOx. EGR is capable of achieving a 50% reduction in NOx emissions or more; however, it can result in an increase in engine-out PM emissions.

NOx catalysts have demonstrated NOx reductions of 10 to 40% whereas *NOx adsorbing catalysts* (also known as *NOx traps*) are capable of 70% or more NOx reduction. These NOx catalysts also provide oxidation capabilities that result in significant reductions in exhaust hydrocarbons, CO and the soluble fraction of PM. NOx traps are in use as one of the technologies to meet the Euro 6 NOx emissions requirements for light-duty vehicles.

Selective Catalytic Reduction (SCR) using urea as a reducing agent has been shown to be the most effective control technology for reducing NOx emissions, exhibiting conversions of up to 90% while simultaneously reducing HC emissions by 50 to 90% and PM emissions by 30 to 50 percent.

Closed crankcase ventilation technology is being installed on all new U.S. 2007 heavy-duty trucks equipped with turbo charged diesel engines to eliminate crankcase emissions. Crankcase emissions vented to the engine compartment have been found to enter cabin air and can be a significant source of driver and passenger PM exposure. These systems capture particulate generated in the crankcase and return them to the lubricating system of the engine.

3.0 SUBSTRATE TECHNOLOGIES

Catalytic converters, traps and filter technologies for the control of emissions use a ceramic (typically cordierite) or metallic honeycomb substrate. This is mounted in a can and is protected from vibration and shock by a resilient 'mat'. The catalytic converter or particulate filter then looks similar to an exhaust muffler.

The technology of the substrates, on which the active catalyst is supported, has seen great progress. Thin walls and increased cell densities allow a larger catalyst surface area to be incorporated into a given converter volume and this allows better conversion efficiency and durability. The thin walls reduce thermal capacity and limit pressure losses. Alternatively, the same performance can be incorporated into a smaller converter volume, making the catalyst easier to fit close to the engine as cars are made more compact. The use of additional catalytic converters close to the exhaust manifold reduces the time to light-off in the cold start and, therefore, the total emissions. Light-off times have been reduced from as long as one to two minutes to a few seconds. Improved substrate technology, combined with highly thermally stable catalysts and oxygen storage components, allows the close-coupled catalyst approach to meet the Euro 4, 5 and 6 standards.

In the original automotive catalyst it was only possible to apply the active coating to the whole substrate. Precision coating technologies now allow different active material compositions to be applied to different areas of the substrate to optimize the performance or, in some cases, to allow different functions. This includes, for instance, coating the inlet end of a particulate filter to act as an oxidation catalyst.

A further option that can be used for some types of catalyst is to incorporate the active materials directly into the ceramic substrate, so that the extruded ceramic matrix provides catalytic activity without further coating. Such 'homogeneous' catalysts are primarily used in some forms of the SCR of NO_x emissions.

Wall-flow particulate filters also typically use a ceramic honeycomb structure of a porous wall design where every alternate channel is plugged on each end. These wall-flow filters can be made from a variety of ceramic materials, notably cordierite, silicon carbide or aluminium titanate. Technological developments in DPF design include advancements in cell shape and cell wall porosity optimization aimed at minimizing engine backpressure and extending the interval between filter service. Advances such as higher pore volume, increased pore connectivity along with thinner web designs facilitate catalyst coating while maintaining longer times between soot regeneration events.

4.0 OXIDATION CATALYSTS

Oxidation catalysts are the original type of autocatalysts and were used from the mid-1970's for gasoline-engined cars until superseded by three-way catalysts. Oxidation catalysts convert CO and HC to CO₂ and water but have little effect on NO_x. They are now rarely used on gasoline cars because of the advantages of TWCs, but may be used on some vehicles running on Compressed Natural Gas (CNG).

The DOC for the control of exhaust pollutants such as CO, HC and PM originate from the early two-way automotive catalysts, and are designed to oxidize unburned components of fuel in the exhaust to innocuous products like CO₂ and H₂O. The reactants may include exhaust hydrocarbons of all types, CO, or the soluble organic fraction (SOF) of the diesel PM. The SOF consists of unburned hydrocarbons from fuel and lube oil that have condensed on the solid carbon particles.

DOCs are most often based on a flow-through honeycomb substrate (either metallic or coated), coated with an oxidizing catalyst such as platinum and/or palladium. Using oxidation catalysts on diesel-powered vehicles is not a new concept. Oxidation catalysts have been installed on over 250,000 off-road vehicles around the world for over 30 years. Tens of millions of oxidation catalysts have been installed on new diesel passenger cars in Europe and on new heavy-duty highway trucks in the U.S since the mid-1990s. These systems have operated trouble free for hundreds of thousands of miles. Oxidation catalysts can be used not only with conventional diesel fuel, but have also been shown to be effective with biodiesel and emulsified diesel fuels, ethanol/diesel blends and other alternative diesel fuels.

4.1 DIESEL OXIDATION CATALYST

In most applications, a diesel oxidation catalyst consists of a stainless steel canister that contains the honeycomb substrate or catalyst support. The substrate may be either made from a ceramic material or metal foil. There are no moving parts, just large amounts of interior surface area. The interior surfaces are coated with catalytic metals such as platinum and/or palladium.

This type of device is called an oxidation catalyst because it converts exhaust gas pollutants into harmless gases by means of chemical oxidation. In the case of diesel exhaust, the catalyst oxidizes CO, HCs, and the soluble organic fraction of PM into CO₂ and water. DOCs also play an important role in continually removing soot from the DPF. This occurs by oxidizing some of the NO to NO₂ which serves to oxidize the soot or by generating heat

through the oxidation of CO and HC to raise the DPF temperature above the soot oxidation temperature.

Figure A1-3: Diagram of a Diesel Oxidation Catalyst

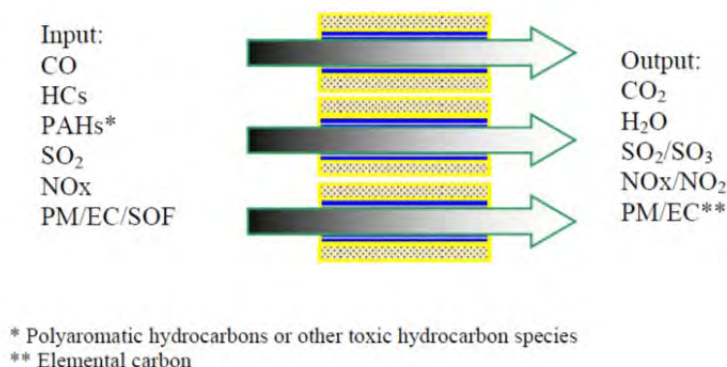

Figure A1-3 shows a representation of three channels of a straight through, flow path honeycomb. The engine out exhaust gases enter the channels from the left and as they pass over the catalytic coating they are oxidized to the reaction products on the right. The particulate matter entering the DOC consists of elemental carbon (EC) and gaseous, semi-volatile SOF. Exiting the catalyst, most of the volatile SOF has been oxidized, as well as, potentially some of the elemental carbon depending on the temperature. The level of total particulate reduction is influenced in part by the percentage of SOF in the particulate. For example, a Society of Automotive Engineers (SAE) Technical Paper [10] reported that oxidation catalysts could reduce the SOF of the particulate by 90% under certain operating conditions, and could reduce total particulate emissions by up to 40 to 50%. PM reductions of 20 to 35% are typical for newer model year engines. Destruction of the SOF is important since this portion of the particulate emissions contains numerous chemical pollutants that are of particular concern to health experts.

4.2 FILTER REGENERATION CATALYSTS

From 1 January 2011 all new light-duty diesel vehicles in the EU have had to meet a PM limit of 5 mg/km. From 1 September 2011 a revised measurement method was introduced for new vehicle types, for which the limit was reduced to 4.5 mg/km and a PN limit of 6×10^{11} particles/km was added. These requirements will be extended to all new vehicles from 1 January 2013. These limits effectively require diesel particulate filters (DPF). In 2007, all U.S. heavy-duty vehicles must have a DPF in the exhaust system to reduce PM to below 0.01 g/bhp-hr. The Euro VI heavy-duty legislation, which all heavy-duty engines will be required to meet from the start of 2014 (2013 for new types), sets PM limits of 10 mg/kWh

together with a PN limit of 6×10^{11} particles/km over the World-Harmonised Transient Cycle (WHTC), and it is expected that DPFs will be needed to meet this limit.

The DPF will be described in greater detail later in this annex. An essential part of the proper functioning of any DPF system relies on a prescribed regeneration to occasionally burn soot collected in the filter and reduce the backpressure of the exhaust stream. Many exhaust control systems rely on a DOC or regeneration catalyst upstream of the DPF to assist with regeneration. This strategy can be applied to either coated or uncoated DPFs and essentially performs two functions. The first is to oxidize unburned HC and CO in exhaust and utilize the exothermic heat of combustion to raise the temperature of the exhaust gas entering the DPF to temperatures sufficient to combust the captured carbonaceous soot. This can be done by enriching the fuel/air ratio going to the cylinders or injecting a small amount of fuel into the exhaust ahead of the DOC. A second regeneration function is to oxidize some of the NO_x in the exhaust to nitrogen dioxide (NO₂) which oxidizes carbon at a lower temperature than oxygen. The presence of higher concentrations of NO₂ thus facilitates filter regeneration at lower exhaust temperatures.

4.3 IMPACT OF SULFUR ON OXIDATION CATALYSTS

The sulfur content of diesel fuel has a important effect on the operation of catalyst technology. Catalysts used to oxidize the SOF of the particulate can also oxidize sulfur dioxide to form sulfate particulate (a mixture of sulfuric acid and water), which adds to the mass of the particulate. This reaction depends on the level of sulfur in the fuel and the temperature of the exhaust gases. DOCs are the most sulfur resistant catalyst technologies being applied to diesel exhaust and were the only type of catalyst that could be used prior to the introduction of ULSD. In most cases DOCs can operate effectively on fuel with up to 500 ppm S, however the activity and function of the catalyst components can be impacted negatively, resulting in a reduction of catalyst efficiency.

Catalyst formulations have been developed which selectively oxidize the SOF while minimizing oxidation of the sulfur dioxide (SO₂). However, the lower the sulfur content in the fuel, the greater the opportunity to maximize the effectiveness of oxidation catalyst technology for both better total control of PM and greater control of toxic HCs. Lower sulfur fuel (500 ppm S; 0.05 wt%), which was introduced in 1993 throughout the U.S., in Europe in 1996, and in Japan in 1997, facilitated the application of DOC catalyst technology to diesel-powered vehicles. Now, the availability of ULSD fuel (15 ppm S; 0.0015 wt% in the U.S. and Canada and 10 ppm S fuel in Europe and Japan) allows for further enhancements of catalyst performance. ULSD fuel was rolled out across the U.S. and Canada in 2006 as part of

EPA's and Environment Canada's 2007-2010 highway diesel engine emissions program³. ULSD is the required fuel for 2007 and newer diesel engines. 10 ppm S fuel became available in the EU and Japan from 2005.

Starting in 2007, the U.S. EPA requires a 500 ppm limit for sulfur on diesel fuel produced for non-road engines, locomotives and marine applications. The rule also sets a subsequent limit of 15 ppm S for non-road diesel by 2010 and by 2012 for locomotive and marine applications. In Europe, the maximum sulfur level of diesel fuel for non-road mobile machinery (which includes inland waterway vessels, railcars and rail locomotives), agricultural and forestry tractors and recreational watercraft was limited to 1000 ppm S from the start of 2008 and to 10 ppm S from the start of 2011. The availability of these fuels allows nonroad engines to fully take advantage of catalyst technology for complying with future EPA Tier 4 emission regulations and EU NRMM Stage IV emissions regulations for non-road, waterway and locomotive diesel engines. California already requires the use of ULSD for all diesel engines except for certain types of ocean-going ships.

³ www.epa.gov/otaq/diesel.htm

5.0 DIESEL PARTICULATE FILTER

5.1 HIGH EFFICIENCY FILTERS

In Europe, vehicles equipped with high efficiency DPFs have been offered commercially since 2000.

In the most common type – wall-flow filters – particulate matter is removed from the exhaust by physical filtration using a honeycomb structure similar to an emissions catalyst substrate but with the channels blocked at alternate ends. The exhaust gas is thus forced to flow through the walls between the channels and the particulate matter is deposited as a soot cake on the walls. Such filters are made of ceramic (cordierite, silicon carbide or aluminium titanate honeycomb materials). **Figure A1-4** simplifies the operation of a wall-flow DPF.

Figure A1-4: Exhaust gas flow through a wall-flow filter channel

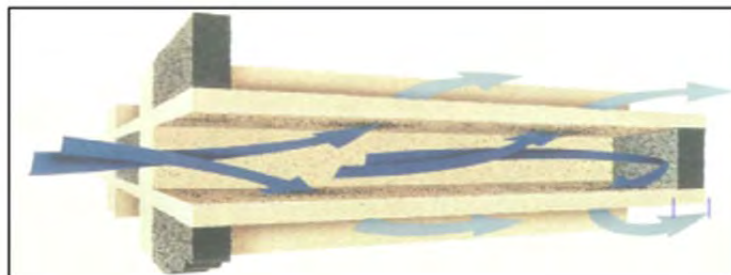

Ceramic wall-flow filters remove almost completely the carbonaceous and metallic particulates, including fine particulates of less than 100 nanometers (nm) diameter with an efficiency of >95% in mass and >99% in number of particles over a wide range of engine operating conditions. Wall-flow filters exhibit high strength and thermal durability.

Beginning with the 2007 model year, all heavy-duty highway diesel engines sold in the U.S. are being equipped with high efficiency diesel particulate filters as part of EPA's 2007-2010 highway diesel engine emission program. All new light-duty diesel passenger vehicles and trucks will be required to employ high efficiency DPFs to meet the U.S. Tier 2 or California LEV II 0.01 g/mile emissions limit for PM. In addition to their use on all new light-duty diesel vehicles in Europe, DPFs are frequently used in meeting European EEV (enhanced environmentally friendly vehicle) emissions standards for heavy-duty engines and are expected to be used to meet Euro VI requirements. High efficiency DPFs are also standard equipment on new highway diesel engines sold in Japan.

Increasing interest has been raised regarding the health impacts of particulate size and number in addition to the total mass. At this time, research has not determined which

physical characteristic or chemical component is the most significant. The European Union has actively pursued the measurement and characterization of ultrafine particles and PN when promulgating new emission regulations. Current European light-duty emission standards include emission limits for both PM mass and number. The future (2013) Euro VI heavy-duty standards also include requirements for both types of PM measurements. The Association for Emissions Control by Catalysts (AECC) conducted a test program for particle size and number on light-duty and heavy-duty vehicles using the procedures outlined in the European Particle Measurement Program (PMP). The heavy-duty testing was conducted using both the European Transient Cycle (ETC), as well as, the World Harmonized Test Cycle (WHTC) and looked at the total number of particles within the range of 25nm to 2.5µm. The results for heavy-duty engines under both test cycles are shown in **Figure A1-5** and demonstrated the efficiency of wall-flow filters to reduce engine out particle number by three orders of magnitude at a filtration efficiency of 99.9%.

Figure A1-5: Particle number measurements with and without wall-flow DPF controls on heavy-duty engines using the PMP guidelines [11]

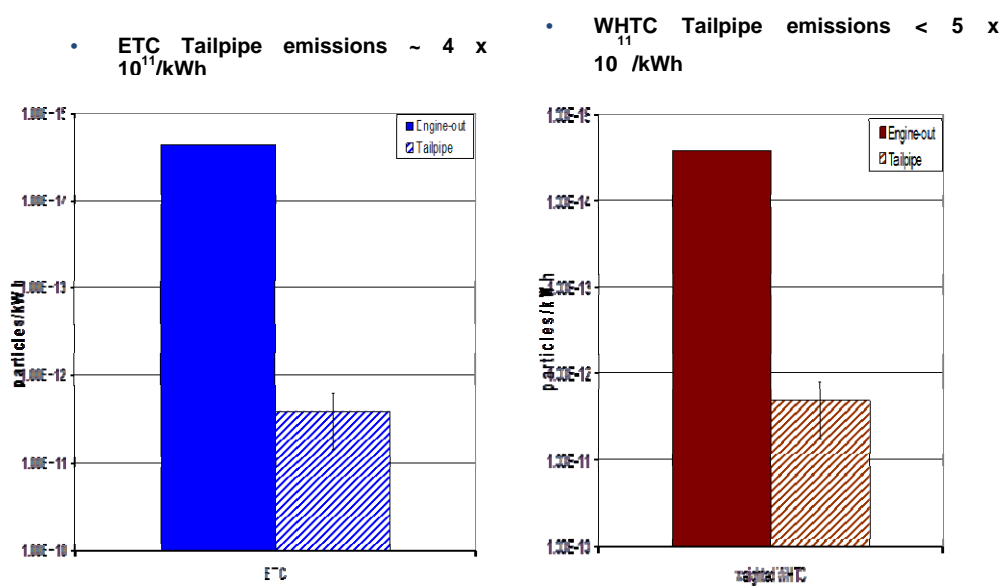

5.1.1 Operating Characteristics and Filter Regeneration

As the name implies, diesel particulate filters remove particulate matter from diesel exhaust by filtering exhaust from the engine. They can be installed on vehicles or stationary diesel engines. Since a filter can fill up over time, engineers that design filter systems must provide a means of burning off or removing accumulated particulate matter. The only practical method of disposing of accumulated particulate matter is to burn or oxidize it within the filter when exhaust temperatures are adequate. By burning off trapped material, the filter is

cleaned or “regenerated.” Filters that use available exhaust heat for regeneration are termed “passively regenerated” filters. Filters that use some kind of energy input, like injection of diesel fuel into an upstream DOC, are termed “actively regenerated” filters. In general, new vehicle applications of DPFs employ a combination of passive and active regeneration strategies to ensure that filter regeneration occurs under all vehicle operating conditions. Active regeneration strategies employ various engine controls to achieve filter regeneration conditions on demand.

Passive regeneration fashion cannot be used in all situations, primarily due to insufficient exhaust gas temperatures associated with the operation of some types of diesel engines, the level of PM generated by a specific engine, and/or application operating experience. To ensure proper operation, filter systems are designed for the particular engine/vehicle application and account for exhaust temperatures and duty cycles of the specific vehicle type. In low exhaust temperature operation an active regeneration strategy may need to be implemented to raise the exhaust temperature sufficient for oxidizing the soot. Actively regenerated, high-efficiency filter systems can be applied to a much larger range of applications.

The most successful methods to achieve regeneration include:

- Incorporating an oxidation catalyst upstream of the filter that, as well as operating as a conventional oxidation catalyst, also increases the ratio of NO₂ to NO in the exhaust [12]. NO₂ provides a more effective oxidant than oxygen and so provides optimum passive regeneration efficiency.
- Incorporating a catalytic coating on the filter to lower the temperature at which particulate burns. New formulations are using ceria or zirconia to make the soot react directly with oxygen at the catalyst-soot interface [13,14].
- Using very small quantities of Fuel-Borne Catalyst (FBC), such as ceria [15] or iron additive compounds added to the fuel using an on-board dosing system. The FBC, when collected on the filter as an intimate mixture with the particulate, allows the particulate to burn at lower exhaust temperatures (around 350°C instead of 650°C) and increases the combustion kinetics (typically 2-3 minutes) while the solid residues of the catalyst are retained on the filter as ashes.
- Fuel injector placed in the exhaust line upstream of the DPF [16]. This provides a source of hydrocarbons to initiate the temperature rise for regeneration.
- Electrical heating of the trap either on or off the vehicle [17].

- Trapped particulate burns off at normal exhaust temperatures using the powerful oxidative properties of NO₂ and can burn in oxygen when the temperature of the exhaust gas is periodically increased through post-combustion. Maximum exothermic temperatures must be controlled, especially in worst-case 'drop-to-idle' conditions when the soot combustion starts at high temperature and flow and then the engine drops to idle.

Diesel particulate filters can be combined with exhaust gas recirculation (EGR), NO_x adsorber catalysts or selective catalytic reduction (SCR) to achieve significant NO_x and PM reductions.

5.1.2 Filter Maintenance

In addition to collecting soot, filters also collect inorganic-based exhaust constituents that are derived from several sources, including the combustion of engine lubricants, products of normal engine wear and/or corrosion, and materials associated with fuel-borne catalysts in DPF applications that use these catalysts to assist in the filter regeneration process. These inorganic oxides do not combust during filter regeneration events. Over extended operation on the vehicle, these ash species slowly accumulate within the filter and gradually increase the pressure drop across the filter. Since excessively high backpressure on the engine will result in a degradation of engine performance, the accumulated ash material within the filter needs to be periodically removed. This ash removal or cleaning operation is a necessary filter maintenance operation. Engine oil consumption characteristics, the total ash content of engine lubricant formulations, vehicle duty cycles, filter designs, and fuel-borne catalyst dosing rates all impact ash accumulation profiles and required filter maintenance cleaning intervals. Because of the toxicity of the material in the DPF, filter cleaning must be done on special machines that will fully capture the material for safe disposal. Many diesel engine service facilities will have the machines.

Filter systems do not appear to cause any additional engine wear or affect vehicle maintenance. Concerning maintenance of the filter system itself, manufacturers are designing systems to minimize maintenance requirements during the useful life of the vehicle. In most U.S. 2007, and later model year, heavy-duty vehicle applications, filter maintenance intervals are expected to exceed 300,000 miles of service. A new generation of low ash containing lubricants has been introduced for these heavy-duty engine applications to help maximize filter cleaning intervals. Manufacturers provide the end-user with appropriate information on filter maintenance schedules.

5.2 PARTIAL FLOW DIESEL PARTICULATE FILTERS AND “FLOW-THROUGH” FILTERS

Diesel Partial-Flow Filters normally use a metallic substrate. The metallic partial-flow filter (**Figure A1-6**) typically uses a special perforated metal foil substrate with a metal 'fleece' layer so that the exhaust gas flow is diverted into adjacent channels and the particles are temporarily retained in the fleece before being burnt by a continuous reaction with the NO₂ generated by an oxidation catalyst located upstream in the exhaust. It offers an option for reducing PM emissions by 30-80% depending on filter size and operating conditions [18,19].

Figure A1-6: Metallic partial flow filter made up of corrugated metal foil and layers of porous metal fleece

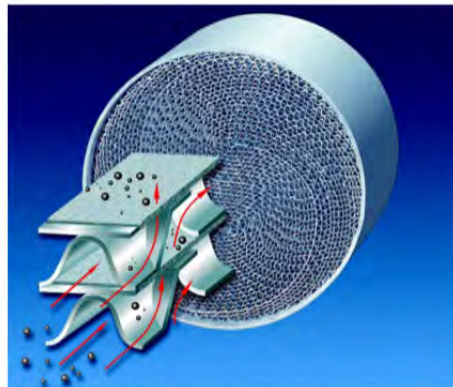

Flow-through filters employ various materials from fibre-based to metallic ‘foams’, including catalyzed metal wire mesh structures and sintered metal sheets to reduce diesel PM. These filters do not have a storage function.

Because of their maintenance free operation, with no active regeneration or ash removal necessary, filters of these types are also verified as a level 2 (>50-84%) PM reduction device under California’s retrofit program. Such filters are capable of achieving PM reduction of about 30 to 80%, depending on the engine operating characteristics.

5.3 IMPACTS OF SULFUR OF PARTICULATE FILTERS

Sulfur in diesel fuel significantly affects the reliability, durability, and emissions performance of catalyst-based DPFs. Sulfur affects filter performance by inhibiting the performance of catalytic materials upstream of or on the filter. Sulfur also competes with chemical reactions intended to reduce pollutant emissions and creates particulate matter through catalytic sulfate formation. Catalyst-based diesel particulate filter technology works best when the fuel

sulfur level is less than 15 ppm. In general, the less sulfur in the fuel, the better the technology performs.

5.4 CLOSED CRANKCASE VENTILATION

In most pre-2007 turbocharged, aftercooled diesel engines, the crankcase is vented to atmosphere often using a downward directed draft tube. While a rudimentary filter was often installed on the crankcase vent, a substantial amount of particulate matter was released to the atmosphere. The particles are predominantly a liquid aerosol generated by the rapidly moving parts in the crankcase. When vented into the engine compartment, they were not only emitted, uncontrolled into the atmosphere, they could easily make their way into the passenger compartment of the vehicle. This PM went undetected in any kind of engine-out PM measurement. Emissions through the crankcase vent may exceed 0.7 g/bhp-hr during idle conditions on recent model year U.S. engines.

All 2007 and newer U.S. engines and Euro VI engines require the control of crankcase emissions and in many cases engine manufacturers are employing closed crankcase systems with filters as shown in **Figure A1-7**. This system consists of a multi-stage filter designed to collect, coalesce and return the emitted lube oil to the engine's sump. Filtered gases are returned to the intake system, balancing the differential pressures involved. Typical systems consist of a filter housing, a pressure regulator, a pressure relief valve and an oil check valve. These systems greatly reduce crankcase emissions. Closed crankcase filter systems can be combined with DOCs or DPFs to reduce PM emissions associated with both the ventilation of the crankcase and the tailpipe.

Figure A1-7: Closed crankcase emission control system

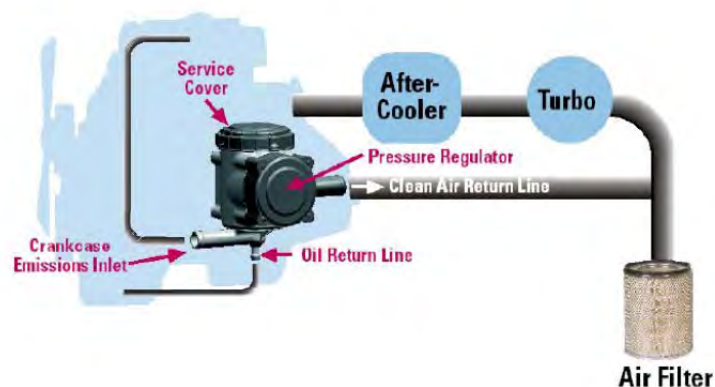

Flow through filter technologies can be coated with catalyst materials to assist in oxidizing the soot or used in conjunction with an upstream diesel oxidation catalyst to oxidize diesel

soot as the exhaust flows through these more turbulent flow devices. These metal devices may see advantages in applications requiring special shapes or having space limitations due to their relatively smaller package size. Flow-through filters generally do not accumulate inorganic ash constituents present in diesel exhaust. The ash passes through the device, reducing the need for filter cleaning in most applications.

6.0 NOX REDUCTION TECHNOLOGIES

The superior fuel economy of diesel engines over gasoline lies in their operation at high air to fuel ratios where there is excess oxygen. The oxygen-rich combustion environment in combination with high combustion temperatures results in the formation of nitrogen oxides (NO_x) in the combustion process. Gasoline engines also generate NO_x by the same mechanisms; however, their typical stoichiometric air/fuel ratio in combination with TWCs allows for very low tailpipe NO_x levels. These approaches are generally not employed on diesel engines in order to maintain the significant fuel economy and low CO₂ benefits of these engines. Therefore, a new set of technologies have been developed by exhaust emission control manufacturers to significantly reduce NO_x in oxygen-rich exhaust streams. Below is a brief overview of the types of technologies that are being developed and commercialized to reduce NO_x from diesel engines and vehicles.

The exhaust streams in lean-burn direct injection gasoline engines are also oxygen-rich and hence, as with diesel engines, new solutions are required for control of NO_x from these engines. Most commonly, at present, NO_x adsorber catalysts are used in passenger car and light-duty applications of lean-burn gasoline engines.

6.1 EXHAUST GAS RECIRCULATION (EGR)

As the name implies, EGR involves recirculating a portion of the engine's exhaust back to the charger inlet (or intake manifold in the case of naturally aspirated engines). In most systems, an intercooler lowers the temperature of the recirculated gases. The cooled recirculated gases, which have a higher heat capacity and lower oxygen content than air, lower the combustion temperature in the engine, thus inhibiting NO_x formation. There are two types of EGR:

- *High pressure EGR* captures the exhaust gas prior to the turbocharger and redirects it back into the intake air.
- *Low pressure EGR* collects the clean exhaust after the turbocharger and after a diesel particulate filter and returns it to the intercooler. Diesel particulate filters are always used with a low-pressure EGR system to ensure that large amounts of particulate matter are not recirculated to the engine which would result in accelerated wear in the engine and turbocharger.

In some cases, engine manufacturers have also incorporated catalysts within high pressure EGR loops to reduce PM levels that are recirculated back through the combustion process.

EGR systems typically recirculate about 25 to 40% of the combustion atmosphere to cool combustion temperatures and are capable of achieving NO_x reductions of more than 40%. A schematic of a low-pressure EGR+DPF system is shown in **Figure A1-8**.

Figure A1-8: Low Pressure EGR plus DPF

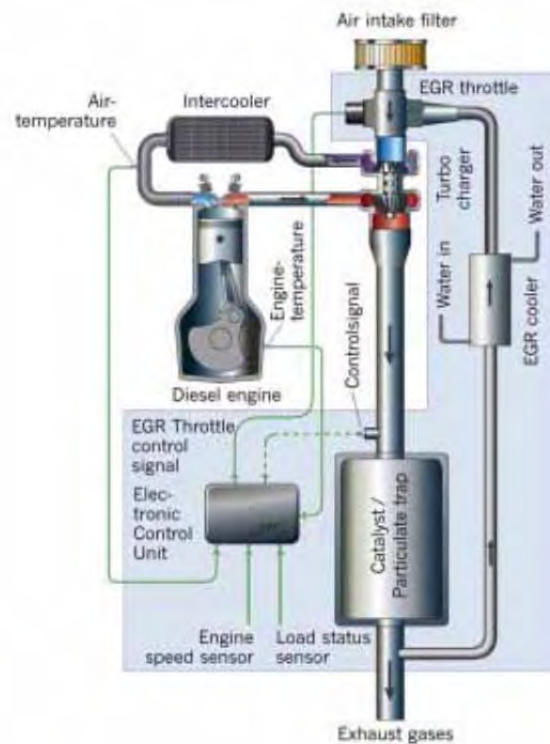

In order to optimize the engine out NO_x reduction over the largest portion of the engine map and improve the fuel economy at the same time, manufacturers have developed combined technology air breathing solutions. The benefits of variable turbine geometry (VTG) turbochargers and low pressure EGR have been combined to provide both efficiency and NO_x reduction. At low engine speeds and loads, the low pressure EGR system maintains the energy flow to the turbine (and thus power and efficiency), while, at higher speeds and high load portions of the engine map, the high pressure EGR system matches the flow requirements within the optimal turbine geometry to minimize losses. The blended EGR (high and low pressure) in combination with a VTG turbocharger can also match all operating conditions and provide better charge temperature control. The optimized combination of technologies is capable of achieving 30% NO_x reduction while delivering a 3-4% reduction in brake specific fuel consumption (BSFC).

6.2 SELECTIVE CATALYTIC REDUCTION (SCR)

SCR has been used to control NO_x emissions from stationary sources such as power plants for over 20 years. More recently, it has been applied to select mobile sources including cars, trucks, marine vessels, and locomotives. Applying SCR to diesel-powered vehicles provides simultaneous reductions of NO_x, PM, and HC emissions. Many engine manufacturers are now offering SCR systems on new highway heavy-duty engines sold in Europe to comply with the European Union's Euro IV or Euro V heavy-duty engine emission requirements. More than 100,000 new, SCR-equipped trucks are operating in Europe using a urea-based reductant.

SCR systems have also been installed on marine vessels, locomotives and other non-road diesel engines. Significant numbers of marine vessels have been equipped with SCR including auto ferries, transport ships, cruise ships, and military vessels. The marine engines range from approximately 1250 hp to almost 10,000 hp and the installations have been in operation since the early to mid-1990s.

SCR offers a high level of NO_x conversion with high durability. Open loop SCR systems can reduce NO_x emissions from 75 to 90%. Closed loop systems on stationary engines have achieved NO_x reductions of greater than 95%. Engine manufacturers in North America are now using combined DPF+SCR system designs for complying with EPA's 2010 heavy-duty highway emission standards. DOC+SCR systems are being used commercially in Japan for new diesel trucks by several engine manufacturers to comply with Japan's 2005 emission standards and are expected to be used in Europe to meet Euro VI standards.

Modern SCR system designs combine highly controlled reductant injection hardware, flow mixing devices for effective distribution of the reductant across the available catalyst cross-section, durable SCR catalyst formulations, and ammonia slip clean-up catalysts that are capable of achieving and maintaining high NO_x conversion efficiencies with extremely low levels of exhaust outlet ammonia concentrations over thousands of hours of operation.

6.2.1 Operating Characteristics and Control Capabilities

An SCR system uses a metallic or ceramic wash-coated catalyzed substrate, or a homogeneously extruded catalyst, and a chemical reductant to convert nitrogen oxides to molecular nitrogen and oxygen. In mobile source applications, an aqueous urea solution is the preferred reductant. In open loop systems, the reductant is added at a rate calculated by a NO_x estimation algorithm that estimates the amount of NO_x present in the exhaust stream. The algorithm relates NO_x emissions to engine parameters such as engine revolutions per

minute (rpm), exhaust temperature, backpressure and load. As exhaust and reductant pass over the SCR catalyst, chemical reactions occur that reduce NO_x emissions. In closed loop systems, a sensor that directly measures the NO_x concentration in the exhaust is used to determine how much reductant to inject.

SCR catalysts formulations based on vanadia-titania and base metal-containing zeolites have been commercialized for both stationary and mobile source applications. The maximum NO_x conversion window for SCR catalysts is a function of exhaust gas composition, in particular the NO₂ to NO ratio. The three common NO_x reduction reactions are:

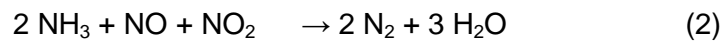

Base metal zeolite SCR catalysts, in particular, have been selected, and are continuing their development, for applications that require NO_x performance and durability under higher exhaust operating temperatures that may be encountered in some mobile source applications. Low temperature SCR is promoted by NO₂. For low temperature NO_x conversion efficiency, emission control system design engineers have a number of options available including the composition of the SCR catalyst itself, control of the ratio of NO₂ to NO present at the inlet of the catalyst, and improving the urea decomposition process at low exhaust temperatures.

SCR catalysts based on vanadia exhibit a strong sensitivity of NO_x conversion to the NO₂:NO_x ratio of the exhaust gas. Optimum conversion is achieved at a ratio of 1:1 or a 50% NO₂ composition. Zeolite based catalysts have shown less sensitivity to NO₂ concentration as shown in **Figure A1-9**.

Figure A1-9. Catalyst A: Cu-zeolite and Catalyst B: Fe-zeolite are compared to a vanadia-based SCR catalyst with respect to NO₂ sensitivity

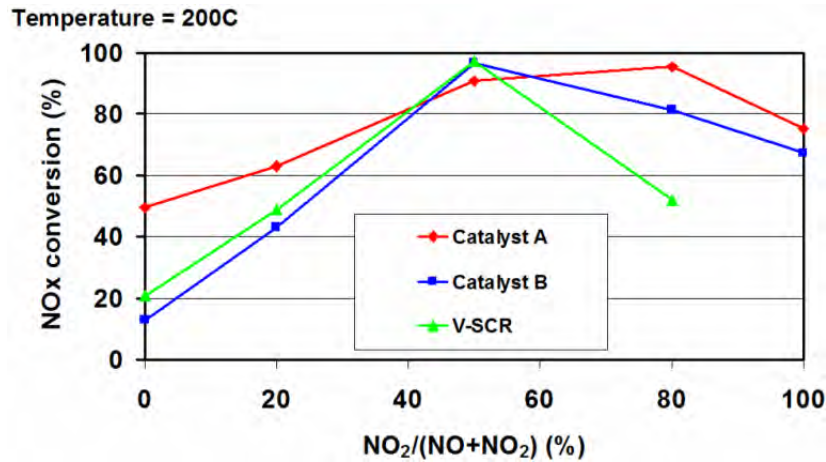

In an actual application, the SCR system can be placed either upstream or downstream of the DPF depending on the temperature sensitivity and filter regeneration strategies employed by the manufacturer. **Figure A1-10** shows a typical arrangement where the SCR is downstream of the DOC/DPF. The final catalyst in the exhaust system is an oxidation catalyst designed to remove any ammonia slip that might occur in the SCR.

Figure A1-10: Diagram showing SCR (green) catalyst downstream of DOC (light gray)/DPF (pink) catalyst, urea dosing nozzle. The blue section represents an ammonia clean-up catalyst. Some of the types of monitors and controls feeding back to the control unit are also shown.

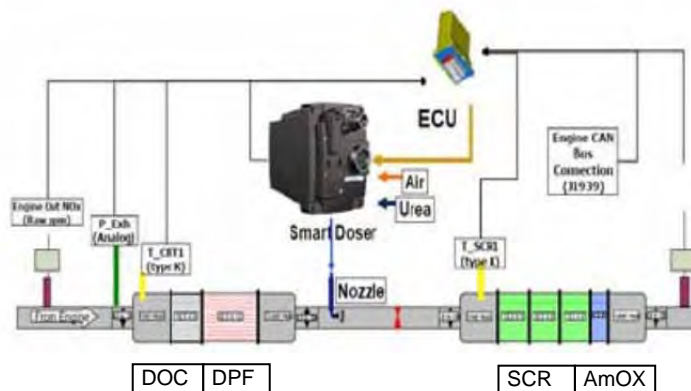

In addition to NO_x, SCR systems reduce HC emissions up to 80% and PM emissions 20 to 30%. They also reduce the characteristic odor produced by a diesel engine and diesel smoke. Like all catalyst-based emission control technologies, SCR performance is enhanced by the use of low sulfur fuel. Combinations of DPFs and SCR generally require the use of ultra-low sulfur diesel to achieve the highest combined reductions of both PM and NO_x.

Significant advancements have been made not only to improve the catalyst performance and durability but also in the urea injection hardware to insure an accurate and well distributed supply of reductant. This insures that the entire catalyst volume is being utilized and the ammonia slip is minimized. Manufacturers have developed high precision injectors and mixer systems to disperse the reductant upstream of the catalyst. Urea injector suppliers are moving away from air driven injectors to airless designs to eliminate the need for air pumps specific to the urea supply, to enable their use in light-duty vehicles and to optimise injections for lower levels of engine-out NO_x.

To ensure that urea-SCR technology for vehicles is never operated without a reductant on board, the U.S. EPA has issued a guidance document to outline the types of fail safe controls manufactures must incorporate into their urea SCR systems to receive vehicle certification (EPA-HQ-OAR-2006-0886; FRL-8242-1). A series of driver warnings and inducements will warn operators when the urea level falls below that required to make it to the next refueling stop. Additional requirements put on manufacturers in the US include assurances that the urea used in the vehicle is of high quality and always available while the engine is running. Similar requirements are incorporated into United Nations emissions Regulations and Euro 5, 6 and VI Regulations

6.3 NOX ADSORBER CATALYSTS

NO_x adsorber catalysts, also referred to as lean NO_x traps (LNT), provide another catalytic pathway for reducing NO_x in an oxygen rich exhaust stream.

6.3.1 Operating Characteristics and Performance

NO_x adsorber technology removes NO_x in a lean (i.e. oxygen rich) exhaust environment for both diesel and gasoline lean-burn direct injection engines. The mechanism involves (see **Figures A1-11** and **A1-12**):

1. Catalytically oxidizing NO to NO₂ over a precious metal catalyst.
2. Storing NO₂ in an adjacent alkaline earth oxide trapping site as a nitrate.
3. The stored NO_x is then periodically removed in a two-step regeneration step by temporarily inducing a rich exhaust condition followed by reduction to nitrogen by a conventional three-way catalyst reaction.

Figure A1-11: NO_x trapping mechanisms under lean operating conditions.

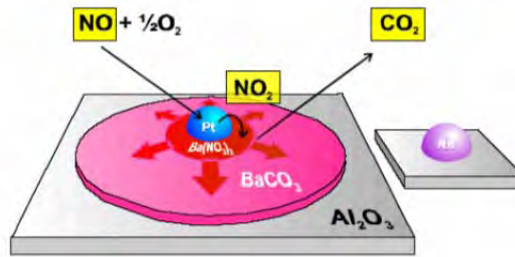
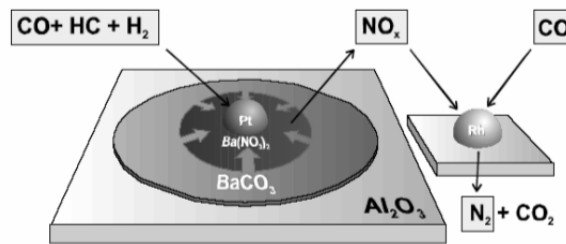

Figure A1-12: NO_x trap regeneration occurs under brief periods of rich operation.



As discussed above, under normal lean diesel engine operation, the NO_x adsorber stores the NO_x emissions. In order to reduce the trapped NO_x to nitrogen, called the NO_x regeneration cycle, the engine must be operated rich periodically for a short period of time (a few seconds). This cycling is also referred to as a lean/rich modulation. The rich running portion can be accomplished in a number of ways including:

- Intake air throttling
- Exhaust gas recirculation
- Post combustion fuel injection in the cylinder
- In-exhaust fuel injection

Development and optimization of NO_x adsorber systems is continuing for diesel engines. Adsorber systems have demonstrated NO_x conversion efficiencies ranging from 50 to in excess of 90% depending on the operating temperatures and system responsiveness, as well as diesel fuel sulfur content. An important consideration in designing a NO_x adsorber emission control system is the effect on fuel economy. LNTs may experience a fuel economy penalty as a result of the fuel necessary to generate a rich exhaust environment during regeneration of the catalyst. There is potential to overcome this associated penalty by utilizing system engineering and taking advantage of all components. For instance, an approach to minimize the fuel economy penalty associated with the NO_x regeneration step

may be to calibrate the engine for maximum fuel economy at points on the engine map where the NO_x adsorber is performing at its peak conversion efficiency. Although such a calibration results in higher engine-out NO_x emissions, with the NO_x adsorber functioning at its peak conversion efficiency, NO_x emissions could still be kept low.

The importance of an engineered systems approach when designing an emission control system using NO_x adsorber technology cannot be underestimated. Conversion efficiency of up to 90 percent are achievable over a broad temperature range and the NO_x efficiency can be directly impacted by changing the lean/rich modulation of the cycle. LNTs can achieve even higher NO_x reduction (>90%) when regenerated with on-board generated hydrogen via a fuel reforming reaction over an appropriate catalyst.

The emission control industry continues to invest considerable efforts in further developing and commercializing NO_x adsorber technology. Specifically, formulations and on-vehicle configurations that improve low temperature performance and lower temperature sulfur removal. Advanced storage components have resulted in lower light-off temperatures and wider operating windows for NO_x conversion.

6.3.2 Impact of Fuel Sulfur and Durability

The same compounds that are used to store NO_x are even more effective at storing sulfur as sulfates. Therefore, NO_x adsorbers also require the use of ULSD fuel. The durability of LNTs is linked directly to sulfur removal by regeneration and is a major aspect of technology development. Sulfur is removed from the trap by periodic high temperature excursions under reducing conditions, a procedure called “DeSO_x”. The DeSO_x regeneration temperatures are typically around 700°C and require only brief periods of time to be completed. However, the washcoat materials and catalysts used in these technologies begin to deactivate quickly above 800°C and therefore methods are being developed to reduce the desulfation temperature. **Figure A1-13** shows how the NO_x conversion window is impacted following numerous sulfation/desulfation cycles. Advanced thermally stable materials have allowed LNTs to achieve durability over their full useful life.

Figure A1-13: Durability of advanced LNTs can be maintained over many high temperature desulfation cycles.

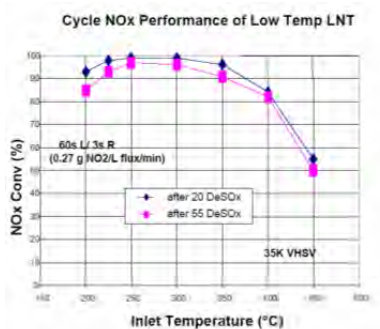

6.3.3 Application of NOx Adsorber Technology

NOx adsorber technology has and has recently been commercialized on a medium duty pick-up truck meeting EPA's 2010 on-highway emission standards and in Euro 6 light-duty diesel vehicles in Europe.

NOx adsorber technology is also being applied to gasoline vehicles powered by gasoline direct injection engines and the results are impressive. In fact, a number of vehicle manufacturers have commercially introduced NOx adsorber catalysts on some of their models powered by lean-burn gasoline engines in both Europe and Japan. While the application of NOx adsorber technology to diesel engines offers different challenges than gasoline applications, the experience being gained in gasoline applications is an important compliment to NOx adsorber technology developments on the diesel side. The U.S. Department of Energy's large Advanced Petroleum Based Fuel-Diesel Emission Control program [20] included vehicle demonstrations of NOx adsorber catalyst technologies that achieved NOx emission reductions in excess of 90% for a light-duty and medium-duty diesel-powered vehicles.

6.4 LEAN NOX CATALYSTS

In the oxygen-rich environment of diesel exhaust, it is difficult to chemically reduce NOx to molecular nitrogen. Direct NOx decomposition is thermodynamically attractive, but the activation energy is very high for this method and no catalysts have been developed for wide-spread use.

Catalysts have been developed that use a reductant like HC, CO, or H₂ to assist in the conversion of NOx to molecular nitrogen in the diesel engine exhaust stream. They are generally called "lean NOx catalysts." Because sufficient quantities of reductant are not present to facilitate NOx reduction in normal diesel exhaust, most lean NOx catalyst systems

inject a small amount of diesel fuel, or other reductant, into the exhaust upstream of the catalyst. The added reductant allows for a significant conversion of NO_x to N₂. This process is sometimes referred to as hydrocarbon selective catalytic reduction (HC-SCR). Currently, NO_x conversion efficiencies using diesel fuel as the reductant are around 10 to 30% over transient test cycles. Other systems operate passively without any added reductant at reduced NO_x conversion rates.

Lean NO_x catalysts often include a porous material made of zeolite having a microporous, open framework structure providing trapping sites within the open cage network for hydrocarbon molecules along with either a precious metal or base metal catalyst. These microscopic sites facilitate reduction reactions between the trapped hydrocarbon molecules and NO_x.

Lean NO_x catalyst systems have been demonstrated and verified for diesel retrofit application and thousands have been commercially applied. However, due to the relatively low NO_x conversions (20-30% over transient cycles) and corresponding fuel economy penalties associated with the operation of these systems, lean NO_x catalysts are generally not being considered for U.S. or EU new vehicle regulations for either light-duty or heavy-duty applications where NO_x conversions of at least 60% are expected to be required. Nonetheless, researchers are developing methods to improve the conversion efficiencies and hydrothermal durability of lean NO_x catalysts to identify formulations that meet the needs of the industry, perhaps in combination with advanced engine technologies like HCCI. One such program has identified several promising catalyst formulations using combinatorial screening techniques with conversion efficiencies as high as 75% on the US06 driving cycle [21].

6.5 COMBINED LNT/SCR NO_x REDUCTION TECHNOLOGIES

Engine and technology manufacturers are looking at novel approaches to address the need for alternative NO_x control systems that do not require separate on-board reductant, like urea. Several hybrid systems were introduced at the 12th Diesel Engine-Efficiency and Emissions Research Conference (DEER) in 2006 and again updated in 2007. These hybrid systems combine the catalyst functionality of lean NO_x traps and ammonia SCR catalysts without the need for a second reductant on board the vehicle. These experimental systems typically incorporate a fuel reformer catalyst to generate a hydrogen rich reformat from the onboard fuel which is then used to regenerate the lean NO_x trap. The regeneration of the LNT forms ammonia which is then stored within the SCR catalyst. The systems primarily rely on the LNT for the bulk of the NO_x reduction during lean operation but the SCR uses the

stored ammonia to further reduce NO_x, thereby extending the time between LNT regeneration and desulfations to reduce fuel penalties associated with these strategies.

Several vehicle manufacturers have announced commercial systems designed to meet EPA's Tier 2 Bin 5 emission standards for 2010 and Euro 6 standards based on a combined NO_x catalyst approach. Some systems rely on dual LNT and SCR catalysts where the SCR stores ammonia formed during LNT regeneration. Another used an LNT together with urea-SCR.

The Mercedes E320 Bluetec system uses independent LNT and SCR catalysts whereas Honda has announced a single catalyst with dual layer functionality. The layered concept incorporates a first washcoat layer based on a NO_x trap catalyst and an outer layer of an SCR catalyst composition. The ammonia that is released during regeneration of the trap is stored within the SCR layer and later utilized for selective catalytic reduction during lean operation.

7.0 EFFECTS OF DIESEL FUEL COMPOSITION ON VEHICLE EMISSIONS

The quantitative measurement of vehicle emissions is a complicated and specialized task because there are a wide range of pollutants emitted and the quantities of these pollutants are now very low. Vehicle emissions can be affected by the composition of the diesel fuel as well as by the engine and after-treatment performance. Many bench engine and vehicle studies have been conducted over many years to investigate the effect on emissions performance of changes in diesel fuel composition and increasingly the use of oxygenates, especially Fatty Acid Esters (FAE).

There are many factors that make it especially difficult to draw robust yet simple conclusions from this extensive literature. These factors include, for example, changes over time in the emissions capabilities of test engines and vehicles; frequently only a small number of vehicles or engines are tested in a given study; differences in test cycles and research objectives; and a lack of orthogonality among critical test variables.

At the same time, diesel fuel specifications have continuously changed to enable new engine and aftertreatment technologies, with the most significant change being the introduction of low-sulphur and sulphur-free diesel fuels. The use of oxygenated components, like FAE, also affects emissions performance and can easily mask the effects due to changes in diesel fuel composition and vehicle and aftertreatment technology. Thus, making sweeping statements about the effects of fuel composition on emissions performance is a complicated task.

One of the most thorough evaluations of these effects was performed in the mid-1990's as part of the European Programme on Emissions, Fuels, and Engine Technologies (EPEFE). This study [22], conducted jointly by the European auto and oil industries, confirmed that both fuels and engine technologies are important determinants of motor vehicle emissions performance and important relationships exist among fuel properties, engine technologies, and exhaust emissions. For diesel fuels, the main fuel parameters investigated were cetane number, PAH, density, and distillation (T95) and special fuel blends were created to separate, as unequivocally as possible, the effects of these compositional parameters on emissions.

The test vehicles and engines were selected in order to reflect the wide range of engine types that were commonly used in Europe in the mid-1990's. The vehicles selected for the study were equipped with state-of-the-art emissions reduction technologies including oxidation catalysts for LD diesels and high pressure fuel injection systems for HD diesels. All

of the LD vehicles exceeded the 1996 emissions limits and HD vehicles exceeded Euro II emissions standards. In total, the study examined 11 diesel fuel blends in 19 LD vehicles and 5 HD bench engines. More than 2000 emission tests were completed using a strictly applied and repeatable testing and measurement protocol.

The study concluded that the relationships between fuel composition and emissions are complex. For example, changes in a given fuel property may lower the emissions of one pollutant but may increase another for a single vehicle type and aftertreatment combination. The study found that the effect of fuel properties on emissions often depended on the engine type, with different types of heavy-duty and light-duty engines frequently showing different responses. For example, increasing the cetane number in diesel fuels tended to reduce NO_x emissions in heavy-duty and light-duty direct injection engines but increase NO_x emissions in light-duty indirect injection engines.

In spite of these observations, the EPEFE study provided detailed and statistically relevant information that could be used as a technical basis for future policy decisions for fuels, vehicles, and emissions. The relationships developed from the data were considered to be valid within the broad range of parameters and protocols used in the study but the authors cautioned that 'great care must be taken in extrapolating the results' to other vehicle and aftertreatment technologies.

Clearly, this study represented a benchmark in internally consistent and robust information. Unfortunately, this is not always the case when one attempts to compare results from different and unrelated studies published in the peer-reviewed literature. We can assume that the results in one published study are valid but extending the interpretation of these results to another study is complex.

Recognising these difficulties, extracting information from the full body of published literature is an approach that has been completed in at least two cases. Koehl et al. [23] published a review of the published literature covering work up to 1989 on the effects of diesel fuel composition on vehicle emissions and Hochhauser [24] published a similar review in 2009.

The latter review was commissioned by the US CRC and covers results from 130 references on on-road and off-road vehicles. For this reason, it is sufficient here to summarise the directional effects that were reported in the 2009 review (**Table A1-1**). It should be emphasized, however, that these directional effects are not straightforward and may be complicated by the diversity of vehicles, aftertreatment systems, fuels, test procedures, and the lack of orthogonality among different test variables.

Table A1-1: Directional effects of diesel fuel composition on emissions from light-duty and heavy-duty diesel vehicles [24]

Summary of Diesel Emission Effects

To Reduce Emissions, Make the Directional Changes Shown Below (Light Duty / Heavy Duty)							
	Density	Cetane	Aromatics/PAH	Sulfur	Back-End	FAE	FT
HC	↓/*	↑/↑	↑/↓	0/0	0/↑	↑/↑	↑/↑
CO	↓/*	↑/↑	↑/*	0/0	0/↑	↑/↑	↑/↑
NOx	*/↓	*/*	↓/↓	0/0	##	↓/↓	#/↑
PM	↓/*	↓/#	↓/↓	↓/↓	↓/↓	↑/↑	↑/↑
0 - No effect; * - Data are lacking to define effect; # - Data exist, but effect is variable							

As shown in this table, the most direct effect of reducing sulfur is to lower the sulfate portion of PM, without changing any of the other engine-out emission components. Reducing sulfur also reduces the number of ultrafine particles. In the studies included in the review, DPFs exhibited a range of sensitivities to sulfur level, with newer models showing lower sensitivity. There is some evidence that higher sulfur levels can result in increased backpressure, which may also affect fuel economy. NSR catalysts have been shown to be sensitive to sulfur above about 50ppm S and may require very low sulfur levels in order to perform well over their expected lifetime. Even when the operation of the NSR is not directly affected by sulfur, higher sulfur levels require more frequent regeneration and the high temperatures associated with regeneration may degrade the catalyst activity over the long-term. Urea-SCR catalyst systems were found to be less sensitive to sulfur levels than NSR catalysts.

Density, aromatics content, especially PAH, and cetane number have been previously documented to affect diesel emissions, although contradictory results have been published. For light-duty diesel vehicles, lowering the diesel fuel density generally lowers HC, CO, and PM emissions but does not affect NOx. Reducing the aromatics content, especially PAHs, lowers PM and NOx emissions but also increases HC and CO emissions.

Increasing the cetane number lowers HC and CO emissions but increases PM emissions. The effects are typically smaller and more difficult to measure accurately when aftertreatment systems, such as DPFs, are used. Diesel oxidation catalysts tend to oxidize the organic fraction of PM. This means that PAH, which may contribute to this fraction of PM, will also have less of an impact in vehicles that are equipped with oxidation catalysts.

For heavy-duty diesel vehicles, lowering the diesel fuel density lowers NOx emissions and reducing the PAH content lowers both NOx and PM emissions. Increasing the cetane

number lowers HC and CO emissions while PM emissions may increase in some modern engines. As engines become more sophisticated in terms of injection control, fuel effects on emissions seem to be less evident. This is especially true for DPF systems that have a very high efficiency for PM reduction and are probably not much affected by nominal changes in PAH content.

In light-duty diesel vehicles, reducing the higher volatility (often called the high-end volatility) of the diesel fuel generally results in a small reduction in PM emissions and does not typically affect HC or CO emissions. The effect of lowering diesel fuel volatility on NOx emissions is less certain, with some literature reporting an increase in NOx emissions.

In heavy-duty diesel vehicles, reducing the volatility of the diesel fuel also lowers PM emissions and increases HC and CO emissions. Some literature reports that NOx emissions increase with lower diesel fuel volatility while other studies report a decrease.

7.1 EFFECTS OF OXYGENATES IN DIESEL FUEL ON VEHICLE EMISSIONS⁴

Many studies have been published on the impact of Fatty Acid Esters (FAE), both methyl and ester types, on regulated and unregulated emissions. For this reason, this section addresses only a subset of recent publications and does not claim to be a comprehensive literature survey. Some examples are provided in each instance as representative of many more that address essentially the same topic.

The effect of FAE type and concentration on regulated emissions has been widely studied. The majority of publications are related to emissions from HD engines and have covered a wide range of different test procedures and protocols. A range of biodiesel types have been tested, including both animal and vegetable based components, both in their untreated and also in their esterified state. A range of concentrations have been examined (up to and including 100% biodiesel) on a variety of engines (both commercial and research) and including a wide range of test conditions. Because of this diversity in tests and results, it is very difficult to develop a consensus from reading the literature alone.

In 2002, however, the U.S. EPA [1] completed an analysis involving more than 800 sets of emissions data. These data were collected from a range of studies which included all of the variables mentioned above and a detailed statistical analysis was completed to summarise the effects of biodiesel fuels on regulated emissions. **Figure A1-14** is reproduced from this

⁴ References for **Section 7.1** can be found in **Annex A1**

study and is frequently cited to show the impact of increasing biodiesel content on emissions.

Figure A1-14: Average emission impacts of biodiesel for heavy-duty highway engines [1]

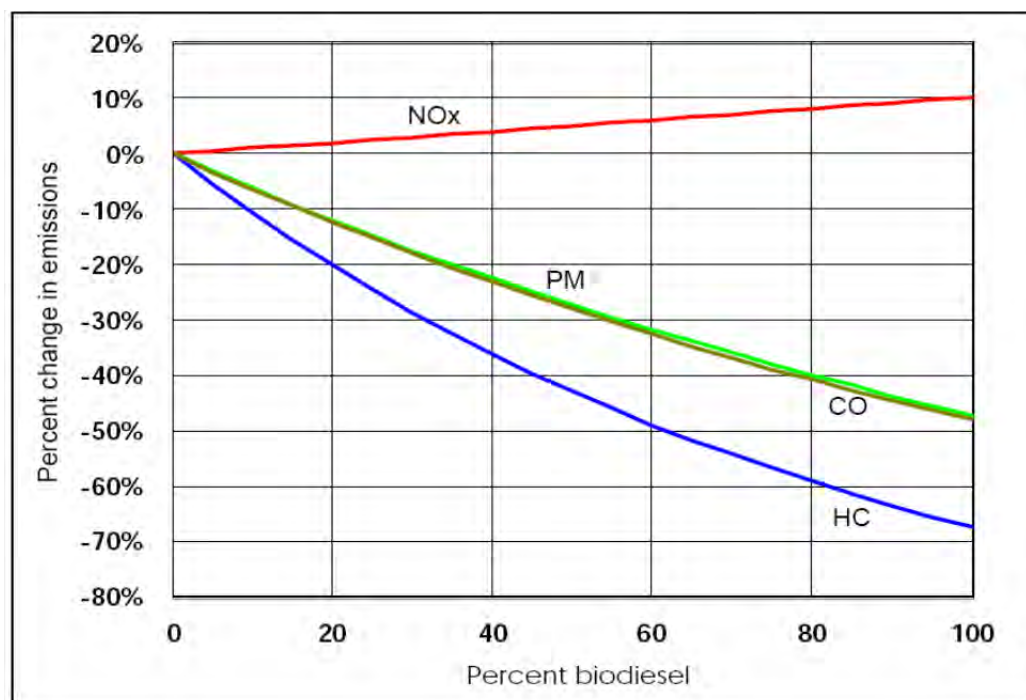

Since this EPA study was reported, this graph has represented the most widely held view on the effects of biodiesel on regulated emissions. It should be emphasized, however, that the study was carried out only on heavy duty engines (primarily US engines) and on a variety of fuels and test procedures (including hot start tests) and did not include engines equipped with after-treatment technologies. Consequently, extending these conclusions to other applications, such as European light-duty diesel vehicles, may not be appropriate.

There are also European publications that relate to heavy duty testing which predate this study. Some gave results in line with those reported by the EPA [2,3,4] while others [5,6] reported differences, normally with respect to NOx emissions, where a reduction in NOx with increasing FAME was reported.

Since 2002, there have been many more publications on heavy duty engine results, again including most of the variables mentioned above. Short of carrying out another EPA-type statistical analysis, it is difficult to compare the magnitude of the results published. However, it is possible to look at the results in their entirety and establish whether they agree with the directional trends already reported in the EPA study.

From our evaluation, many publications were found that agree completely with the EPA trends [7,8,9,10,11] while others show some variation, again, most commonly with respect to NO_x [12,13]. One paper [14] addressed the use of a catalytic converter on a heavy duty engine and reported that its use resulted in a corresponding reduction in NO_x as the biodiesel concentration increased.

However, results from heavy duty engines, and especially engines typically used in the US market, cannot necessarily be extrapolated to the European passenger car fleet in which common rail engines dominate, exhaust aftertreatment systems such as oxidation catalysts and DPFs have become standard equipment and the diesel fuel used as basic blendstock has a significantly higher cetane number than in the US. Furthermore, the European certification test emphasises cold engine starting conditions where the presence of biodiesel can have a different impact compared to hot start conditions.

There are considerably fewer publications related to the effect of biodiesel in light duty applications. Again, the available papers cover a wide range of variables with respect to FAE, concentration of blends, engine conditions etc. One early paper [4] presented limited results using neat rapeseed methyl ester (RME) and concluded that all regulated emissions (including NO_x) were reduced when FAE was used. Another relatively early paper [15] showed reductions in HC and CO and increases in NO_x, but no effect on PM.

Other papers on emissions from light-duty vehicles [13,16,17,18,19] showed emissions trends that are similar to the EPA study, while some others [20,21,22] report reductions in NO_x and one [23] reported an increase on HC and CO.

In a recent and quite extensive review, Lapuerta et al. [24] summarised these results in the following table regarding the impacts of biodiesel on gaseous pollutants, power output, and fuel consumption (**Table A1-2**). The table shows the percentage of scientific studies reporting either increases, decreases or no changes in various emissions and operation characteristics. The results are qualitative because the different conditions and protocols used in the studies do not make a direct comparison possible. In contrast to the EPA study, this table indicates that there are general trends but, in certain cases such as for NO_x and efficiency, no straightforward conclusion can be drawn.

Table A1-2 Estimated share of literature (in percentage of number of publications) reporting decreases, similarities or increases in engine performance and emissions using biodiesel and diesel fuels [24]

	Increases	Same ^a	Decreases	Synergies
Effective power (full load)	-	2	96	2
Brake-specific fuel consumption	98	2	-	-
Thermal efficiency	8	80	4	8
NO _x emissions	85	10	5	-
PM emissions	3	2	95	-
THC emissions	1	3	95	1
CO emissions	2	7	90	1

^a Many references included in this category have reported both increases and decreases depending on engine load conditions, engine type, engine operation temperature, etc.

LAT/AUTH has also performed an extensive literature review [25] for the EEA on the impact of biodiesel on pollutant emissions and fuel consumption. The results confirmed that the use of biodiesel results in higher NO_x and lower PM emissions. The size of these effects is related to the biodiesel concentration, the vehicle operating conditions, and the engine technology. The effect of biodiesel on CO and HC is generally reported to be beneficial. However, only limited studies were conducted on modern vehicles equipped with diesel oxidation catalysts or other exhaust aftertreatment technologies, configurations which might change this picture. Because of this, the picture regarding CO and HC might be significantly different for modern diesel passenger cars.

In a recent study [26], five different biodiesel blends were tested in order to examine their impact on the emissions and consumption of a common-rail passenger car. Small effects were observed on CO₂ emissions, with only two (PME, SUME) of the five blends providing statistically significant differences. However, these differences were rather limited and in opposite directions and there was no global conclusion on the effect of biodiesel on tailpipe CO₂ emissions. The effect of biodiesel on HC and CO emissions was more prominent over the cold-start driving cycles where the absolute HC and CO emission levels were higher. Over these cycles, B10 fuels resulted in ~25% higher HC and CO emissions than B0 diesel fuel. The ratios of HC and CO emissions over cold-start and hot driving cycles were different for the B0 and B10 fuels. These results indicated that DOC performance was different when

biodiesel was used. The effect of different biodiesel blends on NO_x emissions was variable, ranging from -7% to +11% on average, depending on the type of biodiesel feedstock.

In addition, a recent study from the Joint Research Centre [27] on two passenger cars did not lead to consistent conclusions. NEDC tests on a Euro 3 common-rail equipped car using B30 and B100 fuels confirmed that the regulated emissions were higher with increasing biodiesel content. The largest effect was observed when neat biodiesel (B100) was used, suggesting that the different properties of the fuels resulted in a non-optimized engine operation, leading to significant increases in certain pollutants, such as CO, HC and NO_x. However, fuel consumption did not seem to be affected by the presence of biodiesel at low concentrations while the increase in fuel consumption was limited to 3% with neat biodiesel (B100). The same fuels, when used on a unit-injector equipped Euro 3 car, led to completely different observations concerning the impact of biodiesel on modern passenger cars. Therefore, the effect of biodiesel blends on NO_x emissions from passenger cars is not straightforward and appears to depend on feedstock, vehicle technology and operating conditions.

8.0 ON-BOARD DIAGNOSTIC (OBD) REQUIREMENTS

Light-duty and heavy-duty diesel vehicles have to incorporate OBD requirements. These diagnostic systems must monitor the functionality of engine combustion processes including fuel injection and sensor operation as well as the proper functioning of the DOC, DPF and NO_x control systems that may be on-board the vehicle. Failures of these emissions control systems must illuminate the malfunction indicator light (MIL).

The OBD requirements for diesel vehicles and engines have led to advances in the development and commercialization of advanced sensor technologies to provide both alarms and closed loop controls. Oxygen sensors are an essential part of the OBD system on gasoline vehicles today to insure that the three-way catalyst is functioning properly. Oxygen sensors in combination with temperature sensors may be used to insure functionality of the DOC by forcing a rich excursion in the typical lean diesel exhaust and monitoring an exotherm or oxygen storage function of the DOC.

Differential pressure monitors are being used to detect failure of the DPF and soot loading models and backpressure monitors are being developed to insure proper regeneration. Ash loading must be incorporated into the models and can alert operators when filter maintenance is required. Several manufacturers are also working to develop soot sensors that would provide a direct measurement of exhaust PM levels that may provide filter diagnostic capabilities.

NO_x and ammonia sensors primarily monitor the NO_x conversion efficiency of the catalyst. NO_x sensors represent state of the art technology that can be applied to diesel engines as part of a broader engine control or diagnostic system used to insure proper operation of the NO_x emission control system. These sensors can be incorporated independent of the NO_x emission control technology used on the vehicle. The sensors can work as part of a feedback loop to the control unit on the emissions system to make real time adjustments and optimize NO_x conversion. The principle of operation of one type of NO_x sensor is based on proven solid electrolyte technology developed for oxygen sensors. The dual chamber zirconia sensing element and electro-chemical pumps work in conjunction with precious metal catalyst electrodes to control the oxygen concentration within the sensor and convert the NO_x to NO and nitrogen. The sensors can be incorporated upstream and downstream of the catalyst, for example, to provide a feedback control loop to the ECU of the emissions system. The ECU can then make adjustments to optimize NO_x conversion performance. In the case of SCR technology, feedback can also be provided to the urea dosing system whereas in the case of lean NO_x trap technology a feedback loop could signal the need for

regeneration of the trap. A NO_x sensor (**Figure A1-14**) looks very much like an oxygen sensor.

Figure A1-14: NO_x sensor and ECU.



9.0 CONCLUSIONS

- A number of technologies exist that can greatly reduce emissions from both gasoline- and diesel-powered vehicles and equipment.
- The widespread availability of low and ultralow sulfur fuels for on-road vehicles and off-road machinery has enabled the application of advanced emission control systems. The expansion of low sulfur fuels for off-road applications allows the implementation of the same advanced control technologies to the full range of diesel vehicles including locomotive and marine engines.
- Diesel oxidation catalysts, diesel particulate filters, selective catalytic reduction (SCR), exhaust gas recirculation and crankcase emission controls have been successfully used on new on-road vehicles. These technologies offer opportunities to greatly reduce emissions of particulate matter, NO_x and other pollutants like toxic HCs.
- Similar technologies are now being applied to light-duty vehicles.
- Three-way catalysts provide efficient control of CO, HC and NO_x emissions from stoichiometric gasoline and gas-engined vehicles.
- A combination of three-way catalysts with either NO_x control technology (typically NO_x traps) is being used to control emissions of lean-burn gasoline vehicles.
- Advanced sensors are being developed to monitor all components of the exhaust control system. These sensors will allow diesel engines to meet the same OBD and emissions requirements already in place for gasoline spark-ignited engines and vehicles.

10.0 APPENDIX 1 REFERENCES

1. Schuckert (2012). Experience of diesel emissions technology in Europe, Diesel Emissions Conference Russia & CIS, St. Petersburg, 7 February 2012.
2. Directive 98/70/EC of the European Parliament and of the Council relating to the quality of petrol and diesel fuels, as amended by Directive 2003/17/EC.
3. US EPA Heavy-Duty Highway Diesel Program, <http://www.epa.gov/otaq/highway-diesel/index.htm>
4. US EPA Tier 2 Vehicle and Gasoline Sulfur Program, <http://www.epa.gov/otaq/regs/ld-hwy/tier-2/index.htm>
5. Regulation (EC) 715/2007 of the European Parliament and of the Council on type approval of motor vehicles with respect to emissions from light passenger and commercial vehicles (Euro 5 and Euro 6) and on access to vehicle repair and maintenance information, as amended by Regulations (EC) 692/2008 and (EU) 566/2011.
6. Directive 2005/55/EC of the European Parliament and of the Council on the approximation of the laws of the Member States relating to the measures to be taken against the emission of gaseous and particulate pollutants from compression-ignition engines for use in vehicles, and the emission of gaseous pollutants from positive-ignition engines fuelled with natural gas or liquefied petroleum gas for use in vehicles, as amended by Directives 2005/78/EC, 2006/51/EC and 2008/74/EC.
7. Regulation (EC) 595/2009 of the European Parliament and of the Council on type-approval of motor vehicles and engines with respect to emissions from heavy duty vehicles (Euro VI) and on access to vehicle repair and maintenance information, as amended by Regulations (EU) 582/2011 and (EU) 64/2012.
8. May, Bosteels, Such, Nicol, and Andersson (2008). Heavy-duty Engine Particulate Emissions: Application of PMP Methodology to measure Particle Number and Particulate Mass, SAE Paper 2008-01-1176, Warrendale, PA.
9. Bosteels, May, Favre, Andersson, Such, and Fagg (2010). Measured Emissions from a Dedicated NRMM Engine fitted with Particulate and NOx Emissions Controls, SAE Heavy Duty Diesel Emissions Symposium, Göteborg, September 2010.

10. Horiuchi, Saito, and Ichihara (1990). The Effects of Flow-through Type Oxidation Catalysts on the Particulate Reduction of 1990's Diesel Engines, SAE Paper 900600, Warrendale, PA.
11. Andersson, J. (2007). Particle results from the AECC Programme and their relationship to PMP; AECC Technical Seminar on heavy-duty Engine Emissions, Brussels, 26 October 2007.
12. Stommel, et al. (1998). Effect of a continuously regenerating Diesel Particulate Filter on non-regulated emissions and particle size distribution, SAE Paper 980189, Warrendale, PA.
13. Koichiro et al. (2008). Development of high performance catalyzed DPF with new soot burning mechanism, Fisita Conference, Berlin, September 2008.
14. Southward and Basso (2008). An investigation into the NO₂-mediated decoupling of catalyst to soot contact and its implications for catalysed DPF performance, SAE 2008-01-0481, Warrendale, PA.
15. Zelenka et al. (1998). Towards securing the particulate trap regeneration: a system combining a sintered metal filter and cerium fuel additive, SAE Paper 982598, Warrendale, PA.
16. Fasolo, Hardy, and Leroy (2009). Exhaust fuel injection system for efficient DPF regenerations, MTZ, 07-08 2009, Vol. 70.
17. Kitagawa, Hijikata, and Yamada (1991). Electric heating regeneration of large wall-flow type DPF, SAE Paper 910136, Warrendale, PA.
18. Rice et al. (2007). Innovative substrate technology for high performance heavy-duty truck SCR catalyst systems, SAE Paper 2007-01-1577, Warrendale, PA.
19. Kaiser, Konieczny, and Essen (2006). Filtersysteme zur Russpartikel-Reduktion im Abgas von Diesel-Kraftfahrzeugen-Technologien und Randbedingungen, HdT-Tagung "Filtration im Fahrzeugen", June 27-28, 2006
20. www.nrel.gov/vehiclesandfuels/apbf/apbf_dec.html
21. CLEERS Workshop 5/2007

22. EPEFE (1995). European Programme on Emissions, Fuels and Engine technologies, EPEFE Report on behalf of ACEA and EUROPIA, Brussels, Belgium.
23. Koehl, W.J. et al. (1991). Effects of Gasoline Composition and Properties on Vehicle Emissions: A Review of Prior Studies, SAE Paper 912321, Warrendale, PA.
24. Hochhauser, A.M. (2009). Review of Prior Studies of Fuel Effects on Vehicle Emissions, SAE Paper 2009-01-1181, Warrendale, PA.

1. EPA (2002). EPA Report 420-P-02-001, October 2002.
2. Grimaldi, et al. (2002). Performance and emissions of a common rail DI diesel engine using fossil and different bio-derived fuels, SAE Paper 2002-01-2017, Warrendale, PA.
3. Yeh, L., et al. (2001). Oxygenates: An evaluation of their effects on diesel emissions, SAE Paper 2001-01-2019, Warrendale, PA.
4. Staat, et al. (1995). The effects of rapeseed oil methyl ester on diesel engine performance, exhaust emissions and long term behavior, SAE Paper 950053, Warrendale, PA.
5. Last, et al. (1995). Emissions and performance characteristics of a 4-stroke DI diesel engine fuelled with blends of biodiesel and low sulphur fuel, SAE Paper 950054, Warrendale, PA.
6. Haas, et al. (2001), Engine performance of biodiesel fuel prepared from soybean soapstock, Energy and Fuels, 2001.
7. Zannis, et al. (2004). Experimental investigation to specify the effect of oxygenated additive content and type on DI diesel engine performance and emissions, SAE Paper 2004-01-0097, Warrendale, PA.
8. Souligny, et al. (2004). Heavy duty diesel engine performance and comparative emission measurements for different biodiesel blends used in the Montreal BIOBUS project, SAE Paper 2004-01-1861, Warrendale, PA.
9. Chuepeng, S., et al. (2007). A study of quantitative impact on emissions of high proportion RME based blends, SAE Paper 2007-01-0072, Warrendale, PA.
10. Krahl, et al. (2005). The influence of fuel design on the exhaust gas emissions and health effects, SAE Paper 2005-01-3772, Warrendale, PA.
11. Xiaoming, L., et al. (2005). An experimental investigation on combustion and emissions characteristics of turbocharged DI engines fuelled with blends of biodiesel, SAE Paper 2005-01-2199, Warrendale, PA.
12. Sharp, C.A., et al. (2005). Heavy duty diesel engine emission tests using special biodiesel fuel, SAE Paper 2005-01-3671, Warrendale, PA.

13. Verhaeven, et al. (2005). Results of demonstration and evaluation projects of biodiesel from rapeseed and used frying oil on light and heavy duty diesel engines, SAE Paper 2005-01-2201, Warrendale, PA.
14. Peterson, et al. (1996). Emissions testing with blends of esters of rapeseed oil with and without a catalytic converter, SAE Paper 961114, Warrendale, PA.
15. Schramm, et al. (1999). Emissions from a diesel vehicle operated on alternative fuels in Copenhagen, SAE Paper 1999-01-3603, Warrendale, PA.
16. Senatore, A., et al. (2000). A comparative analysis of combustion process in DI diesel fuelled with biodiesel and diesel fuel, SAE Paper 2000-01-0691, Warrendale, PA.
17. Grimaldi, et al. (2002). Common rail HSDI diesel engine combustion and emissions with fossil/bio-derived fuel blends, SAE Paper 2002-01-0865, Warrendale, PA.
18. McGill, et al. (2003). Emission performance of selected biodiesel fuels, SAE Paper 2003-01-1866, Warrendale, PA.
19. Kawano, D., et al. (2006). Application of biodiesel fuel to modern diesel engine, SAE Paper 2006-01-0233, Warrendale, PA.
20. Lance, D., et al. (2004). Emissions performance of pure vegetable oil in two European light duty vehicles, SAE Paper 2004-01-1881, Warrendale, PA.
21. Tzirakis, E., et al. (2007). Impact of diesel/biodiesel blends on emissions from a diesel vehicle operated in real driving conditions, SAE Paper 2007-01-0076, Warrendale, PA.
22. Arapaki, N., et al. (2007). Regulated and unregulated emissions characteristics of a diesel vehicle operating with diesel/biodiesel blends, SAE Paper 2007-01-0071, Warrendale, PA.
23. Aakko, P., et al. (2000). Emission performance of selected biodiesel fuels, VTT Report ENE5/33/2000.
24. Lapuerta, M., et al. (2008). Effect of biodiesel fuels on diesel engine emissions, Science Direct: Progress in Energy and Combustion Science 34, 198-223, 2008.
25. Kousoulidou, M., et al. (2009). Evaluation of biodiesel blends on the performance and emissions of a common-rail light duty engine and vehicle, SAE Paper 2009-01-0692, Warrendale, PA.

26. Fontaras, G., et al. (2009). Effects of biodiesel on passenger car fuel consumption, regulated and non-regulated pollutant emissions over legislated and real world driving cycles, *Fuel*, 88, 1608-17 (2009).
27. Martini, G., et al. (XXXX) Effect of biodiesel fuels on pollutant emissions from Euro 3 LD diesel vehicles, JRC 37030
28. Fontaras, G., et al. (2011). Impact of straight vegetable oil-diesel blends application on vehicle regulated and non-regulated emissions over legislated and real world driving cycles, *Science Direct: Biomass and Bioenergy*, 35, 3188-3198 (2011).

APPENDIX 2 METHODS FOR CHARACTERIZING DIESEL EXHAUST AND OPERATIONAL FACTORS THAT CAN AFFECT THE RESULTS

“Diesel exhaust particulate” is generally defined in any experiment as “whatever material gets collected on filters used to sample the exhaust”. It is collected, weighed and analyzed by various means. Thus the material identified as diesel particulate is affected by engine design and operation, by fuel chemical composition and by exhaust handling and sampling procedures, including dilution ratio, sampling temperatures exhaust filter material, and even by ambient conditions (Clark et al. (2002)). In laboratory experiments, standardized test methods have been established to exercise the engine over a known and carefully controlled operating cycle and to dilute and sample the exhaust in a consistent way in order to observe the impacts of other variables, such as various engine and fuel design parameters, separate from operational or environmental effects. Having said this, there are many standardized test cycles, and many researchers choose to create their own customized operating and exhaust handling systems to suit their particular experimental design. This variation in test methods introduces significant variation in exhaust quality and hence introduces significant uncertainty in interpreting and extrapolating results of exposure studies. And it means that the engine operation and exhaust sampling procedures in any set of experiments designed to measure, analyze or employ diesel exhaust must be carefully characterized and understood. This Appendix introduces the reader to a number of factors which must be considered.

Traditionally, diesel PM has been collected and then analyzed to determine the distribution of mass and chemical composition of the PM. The most commonly used method to determine the gravimetric PM mass is to use the sampling technique described in U.S. EPA, Protection of Environment, Code of Federal Regulations, Part 86; Title 40 (40CFR86 Subpart N and the current 40CFR1065). Diluted liquid and solid particles are representatively collected on filters by mechanisms including diffusion, impaction, interception, and electrostatic attraction. The chemical composition and mass of the collected PM can then be quantified with a variety of analytical techniques.

Filter sampling is sensitive to thermodynamic and chemical phenomena and is also accompanied by potential reactions of gases with the PM on the filter or with the filter medium during sampling and the absorption of water from humid air (Finlayson-Pitts and Pitts (2000)). Khalek (2007) and Watts and Kittelson (2002) identified primary and secondary dilution conditions (humidity, temperature and dilution ratio) as key factors driving diesel particle dynamics and behavior. Particle nucleation rates are highly non-linear functions of the saturation ratio and thus strongly dependent on dilution ratio. In the presence of

nucleation sites or hygroscopic chemical species like sulfur dioxide, heterogeneous nucleation can occur even at low saturation ratios. These phenomena result in gas-phase species becoming particle phase and thus susceptible to deposition on the filter substrate. Dilution method and sample residence time are also identified as having an impact in the same studies. As can be seen in **Figure A2-1**, lower dilution air temperature, lower dilution ratio, increased residence time and higher relative humidity directionally increase the particle number concentration of diesel PM and accordingly affect deposition behavior during sample collection on the filter substrate.

Figure A2-1: Impact of Residence Time (PRT), Dilution Ratio (PDR) and Dilution Temperature (PDT) on Diesel Particle Number Emissions (Watts and Kittelson (2002))

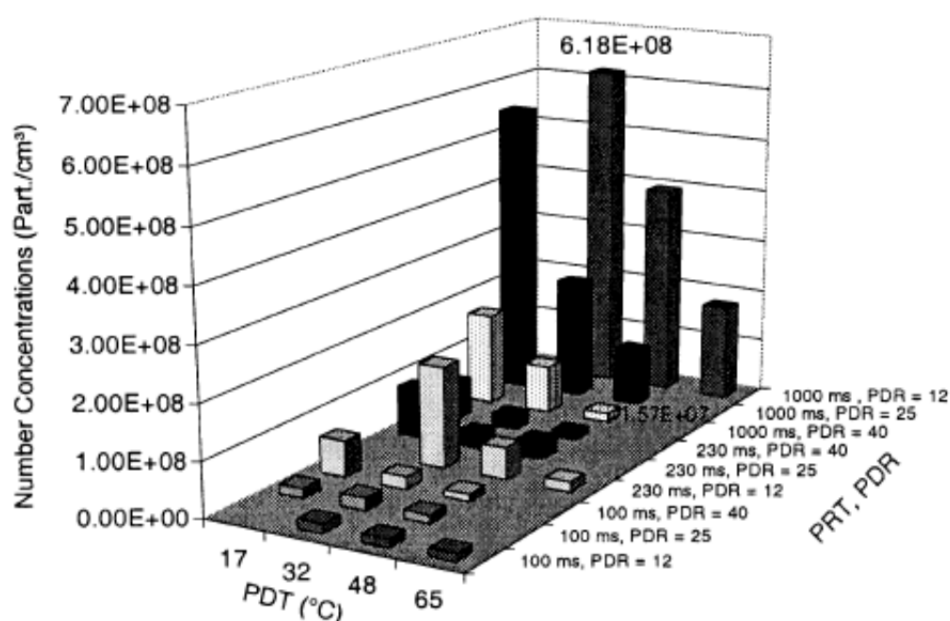

Park et al. (2003) have identified the adsorption and desorption of gas-phase species onto filters and/or the volatilization of semi-volatile compounds from collected PM during sampling as factors affecting the composition of the sample. In the same study, they list chemical reactions between collected particles, between gases and collected particles, and between collected particles and the filter substrate (media) as potential causes for mass and composition changes.

Chase and Duszkievicz (2004) found that commonly used filter substrates for emissions sampling have high efficiency for small particles but also collect gas-phase chemical species with a lower, but non-zero efficiency. They found the collection and retention efficiency of these semi-volatile organic compounds to be influenced by several factors including temperature, relative humidity, particulate loading, the properties of the filter medium and the gas-phase composition of the sample. The impact of different filters is shown in **Figure A2-2**.

Figure A2-2: PM Mass Artifact due to Adsorption of Semi-Volatiles
(Chase and Duszkievicz (2004))

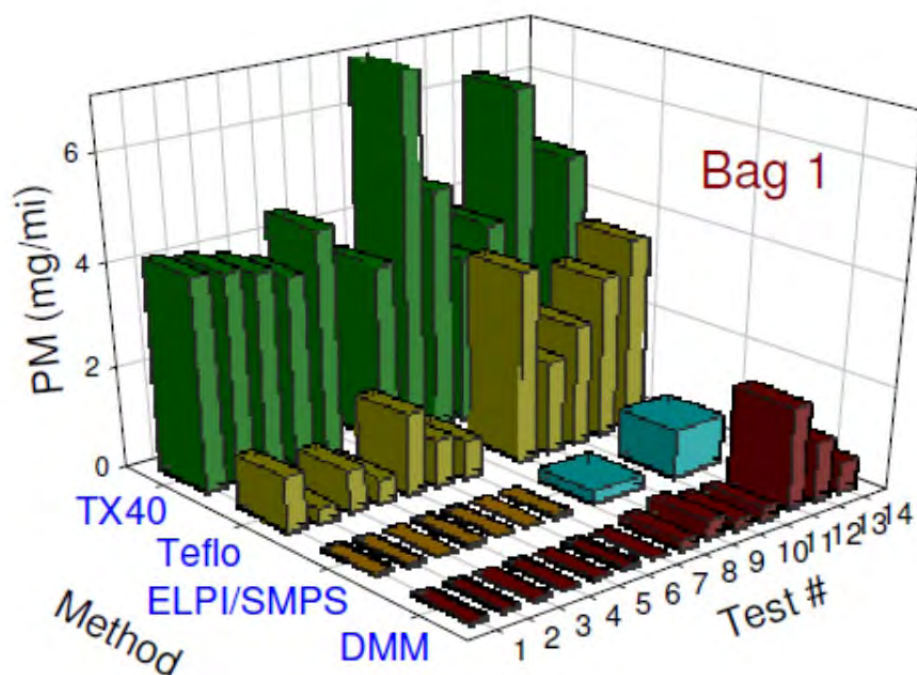

In another study by McDow and Huntzicker (1990), filter pressure drop and face velocity are identified as other factors determining absorption and retention of hydrocarbon. Reduced pressure downstream of the filter substrate will reduce the local vapor pressure of semi-volatile compounds and drives desorption of these species from the filter and accumulated PM.

Kittleson and Johnson (1991) conducted a study on the sources of variability in particulate measurements using the Heavy Duty Transient Test (40CFR86 Subpart N). This comprehensive study identified sources of variability and involved a critical examination of test procedures, visits to representative test facilities and the development of a simplified model of the systems and procedures used to collect PM. Some of these sources are thermophoretic deposition of PM on to walls of the sampling system followed by subsequent re-entrainment in an unpredictable manner, the influence of dilution and cooling upon the soluble organic fraction of the particulate, inconsistencies among laboratories in the dynamometer control strategies and errors in the measurement of flows into and out of the secondary dilution tunnel. They provided recommendations for decreasing variability. The principal recommendations included standardizing engine and tunnel conditioning procedures, reduction of heat transfer during sampling and dilution, control of dilution ratio, tighter specification of the test cycle, and more accurate measurement of flows to and from

the secondary tunnel. They also pointed out that details of particle dynamics which were unimportant when particulate emissions standards were greater than 0.1 g/bhp-hr must be re-examined. Since their study, emissions standards have been lowered to 0.01 g/bhp-hr and EPA's 40CFR1065 has introduced procedural improvements from those in the earlier 40CFR86 Subpart N to improve particulate measurements at the new low emissions standards.

Another study on "2007 Diesel Particulate Measurement Research," (Khalek et al. (2007)) organized by the Coordinating Research Council (CRC E66 Project) also had a major influence on particulate measurement test procedures in 40 CFR1065. The study was a comprehensive look at sampling system parameters and filter types using CVS gravimetric particulate sampling and real time PM instruments to gage influences of these parameters on PM at the 2007 PM levels of 0.01 g/bhp-hr and lower. A fully functioning Diesel Particulate Filter and an arrangement to bypass some of the engine exhaust around the filter to look at PM emissions levels that were still below 0.01 g/bhp-hr but at levels where measurement uncertainty was improved. The study looked at a number of different PM filter media. The Whatman Teflo media, a Teflon membrane with a polymethylpentene ring, gave the lowest positive artifact mass (material that was bound to the filter media due to the ability of the filter media to capture gaseous components of the exhaust without allowing them to pass through as would be normally expected.) It also gave the lowest coefficient of variation in comparison to TX 40 (the filter media type prescribed by EPA in 40CFR86 Subpart N and other Teflon membrane filters). As a result of these experiments, the use of the Teflo filter was recommended for future measurements of PM – a recommendation that was supported by EPA by specifying it in 40CFR1065.

The CRC E66 Project also showed that dilution parameters, such as primary and secondary dilution ratio along with primary and secondary residence time, had a profound impact on particle mass measurement using real time particle instruments. A high dilution ratio and a long residence time seemed to significantly increase PM formation. More than one order of magnitude of PM increase was observed by increasing the secondary dilution residence time from 0.5 second to 18 seconds. Measured PM increased by more than five times when the primary dilution ratio was increased from 2 to 9 using split engine exhaust at a fixed constant volume sampler (CVS) flow rate. The observed increase in measured PM with increasing primary dilution ratio may also be a result of increased residence time between the exhaust and dilution air point of mixing and the CVS sample zone due to reduced temperature and velocity in the full flow CVS (Khalek et al. (2007)).

The studies such as Kittleson and Johnson (1991) and the CRC E66 were carried out to improve PM measurement techniques to satisfy regulatory needs as emissions regulations were reduced to 0.1 g/bhp-hr and 0.01 g/bhp-hr. However, techniques generally used in exposure studies are not conducted with the same level of diligence as is required for regulated tests. It is generally not possible to duplicate regulated engine test cycles in the real world, and the impact of a variety of parameters that affect PM emissions and also their chemical composition due to the variation in the sampling parameters such as temperature, dilution ratio, humidity, residence time, filter face velocity, pressure drop across the filter, wall effects etc. can affect what is collected and hence their chemical composition and the outcome of the exposure studies.

Test Cycles: Emissions are test cycle dependent.(Clark et al. (2002)). Engine and vehicle testing includes many different transient and steady-state test methods, each designed to represent typical engine operation under various operating conditions.

The importance of test cycle impact on emissions has prompted regulating agencies and air quality investigators to develop standard test cycles, including steady state engine operating points and transient test cycles. The Dieselnet website⁵ provides a comprehensive report on test cycles (Dieselnet (2012)). Zhen (2009) and Bedick et al. (2009) provide examples of test cycle impacts on emission results. Since engine operating conditions result in exhaust emission differences, regulatory standards for exhaust emission limits require that governments set precise test methods. Engine and vehicle testing includes many different transient and steady-state test methods, each designed to represent typical engine operation under various conditions. Additional references of interest include Stein et al. (1989), U.S. EPA (2004), U.S. EPA (2010), and DieselNet (2012). A comparison of current European Test cycles for heavy-duty diesel engines and the more recent Euro VI test cycles is provided by Verbeek et al. (2008). The Euro VI cycles will be adopted in Europe in 2013-2014. Details of current and future test procedures for on-highway and non-road engines, including pending regulatory amendments, are specified in the directives published by the European Commission⁶.

The ACES Phase 1 program, (Khalek et al. (2011)) ran a variety of engine test cycles to generate data for sampling regulated and unregulated emissions. Those cycles were deemed representative of how heavy-duty diesel engines are typically used, and therefore were expected to generate levels of regulated and unregulated emissions that were reasonably representative of typical human exposures. The set of test cycles included many

⁵ <http://www.dieselnet.com/standards/cycles/index.php>

⁶ http://ec.europa.eu/enterprise/sectors/automotive/documents/directives/index_en.htm

that are commonly used (EPA Part 86, and EPA Part 1065), as well as new cycles that CARB and U.S. EPA believed were improvements of existing test methods.

Most engine test programs do not include as many different test cycles as utilized in ACES. Rather than review the many different engine test cycles, this Appendix focuses on ACES as representative of heavy-duty diesel emissions test programs. Light duty vehicles usually use different test cycles but these are considered to be beyond the scope of this report.

Turning to a more detailed focus on ACES, the specific ACES Phase 1 test cycles are:

- Hot start FTP, 20 minutes (a transient test used to certify diesel truck engines)
- Mode 1, rated speed, 100% load, 20 minutes (a steady state mode)
- Mode 3, rated speed, 10% load, 20 minutes (a steady state mode)
- Mode 5, peak torque speed, 100% load, 20 minutes (a steady state mode)
- Hot start FTP, 20 minutes (with and without crankcase blow-by)
- Cold start FTP, 20 minutes
- CARB composite cycle in 3 parts: creep, transient and idle, 39 minutes (transient operation)
- CARB 2 part highway cycle: Cruise and high-speed, 48 minutes (transient operation)
- 16-hour cycle (transient operation)

The ACES test cycles and exhaust characterization methods are not universally utilized in engine test programs, but rather represent a wide spectrum of exhaust sample methods that can serve as a guide for future test programs.

The 16-hour transient cycle was developed specifically for the animal bioassays that comprise Phase 3 of ACES, and consists of four repeated test segments, each 4 hours long. The 16-hour cycle duration was selected due to the Phase 3 bioassay plan that required animal exposure for 16 hours per day to ensure sufficient exposure over the lifetime of the study animals (rats). The four hour segment was developed by West Virginia University (WVU) and is based on WVU's experience gained during several emissions testing programs that surveyed in-use vehicles in several US locations (Zhen (2009), Bedick et al. (2009)).

Exhaust Sampling, Raw and Dilute: Gaseous and particulate emissions can be sampled under either raw or dilute conditions. However, particulate sampling must be diluted even if the first sampling step is from undiluted exhaust. The dilution step for particulate sampling is

required to ensure that hydrocarbon vapors condense onto the particles to simulate ambient exposure conditions. When particulates reach the sample filters, the temperature must be $47^{\circ}\text{C} \pm 5^{\circ}\text{C}$ (range of 42° to 52°C). U.S. EPA 40 CFR Part 1065 provides more details of the required sampling conditions. The emissions test methods in Europe are similar to those used in the U.S., although the specific European engine test cycles reflect specific road and use conditions that differ somewhat from the U.S. EPA and CARB test cycles.

Exhaust Sampling, Dilute: Until U.S. EPA defined filter face temperature for particulate sampling at $47^{\circ} \pm 5^{\circ}\text{C}$ and limited the range of exhaust dilution, exhaust particulate measurements had been conducted under a variety of dilution conditions in past studies. Limits on exhaust dilution were established so that the same dilution conditions utilized with full-flow dilution Constant Volume Sampling (CVS) could also be used with partial-flow dilution systems. The allowed particulate sampling temperature range was specified for two reasons: the upper range ensures that volatile species are condensed onto primary exhaust particles to simulate ambient exposures; and the lower range avoids sampling at temperatures that force the condensation of water vapor onto the filters. Water is a product of hydrocarbon fuel combustion, and water condensation onto filters confounds the measurement of exhaust particle mass.

Chemical Characterization: Exhaust emission compounds of regulation interest comprise a small fraction of the exhaust mass that flows through a diesel engine. At maximum engine power, most of the intake and exhaust mass consists of nitrogen, 75%. Other exhaust compounds are oxygen, 7%, water 9%, and carbon dioxide 9% and regulated emissions. The regulated emission of highest concentration, NO_x, is less than 0.03%. CO, HC and particulate concentrations are far less than current NO_x concentration levels, and NO_x is even lower for 2010 on-highway engines. Thus measuring the regulated emissions of interest is very challenging and requires carefully designed and executed procedures. Unregulated emissions are a subset of hydrocarbons and particulates, and due to their small concentration (far less than 0.03% reported above for NO_x), their measurement is an even greater challenge compared to regulated emissions, even for non-aftertreatment-equipped engines.

Chemical composition of the fuel, exhaust hydrocarbons and particulate matter can be interactive and confounding. Wall and Hoekman (1984) demonstrated that sulfate particulate (primarily present as sulfuric acid) could have the effect of “scrubbing” vapor-phase hydrocarbons out of the gas stream to be measured as particulate matter, even showing that “backup” filters downstream of the primary sampling filters could collect hydrocarbon artifacts if doped with sulfuric acid (**Figure A2-3**).

Figure A2-3: Effect of sulfuric-acid doping of particulate filters on the mass of collected soluble organic material at the cruise condition for both primary and backup particulate filters (Figure 16, Wall (1984))

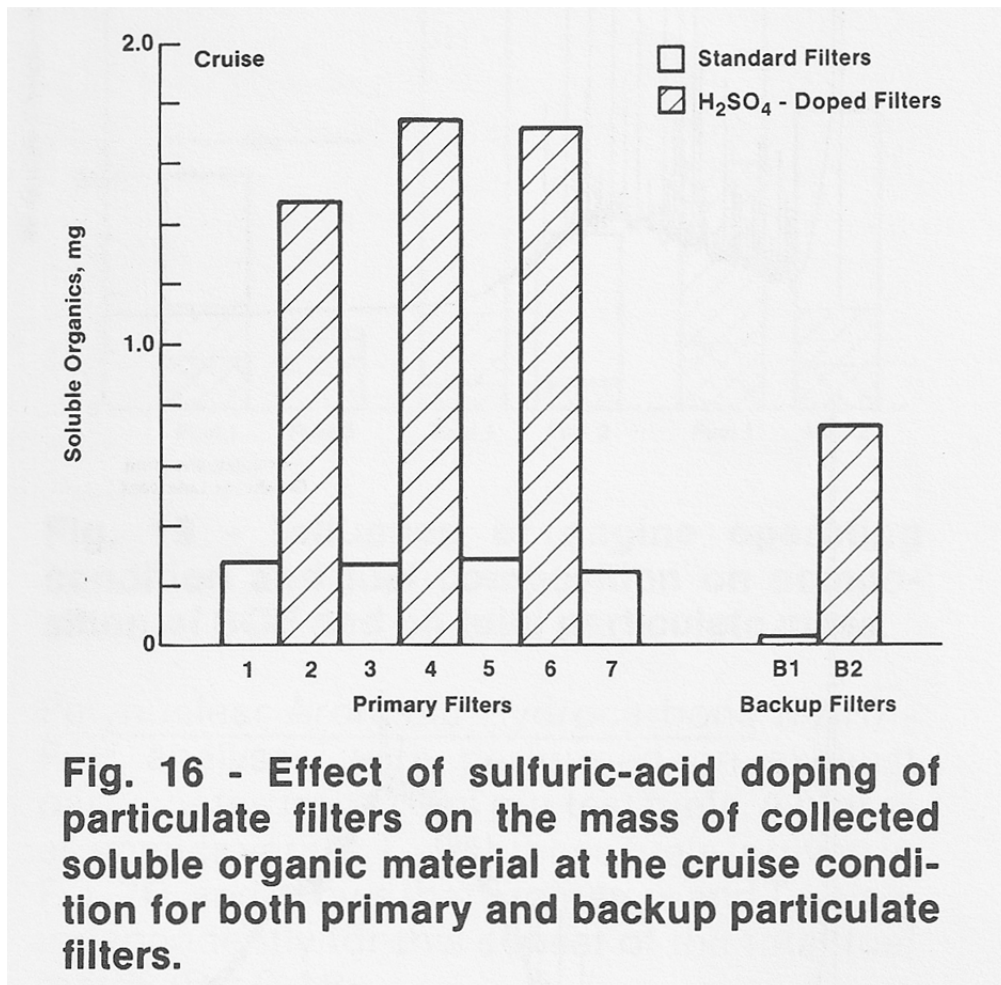
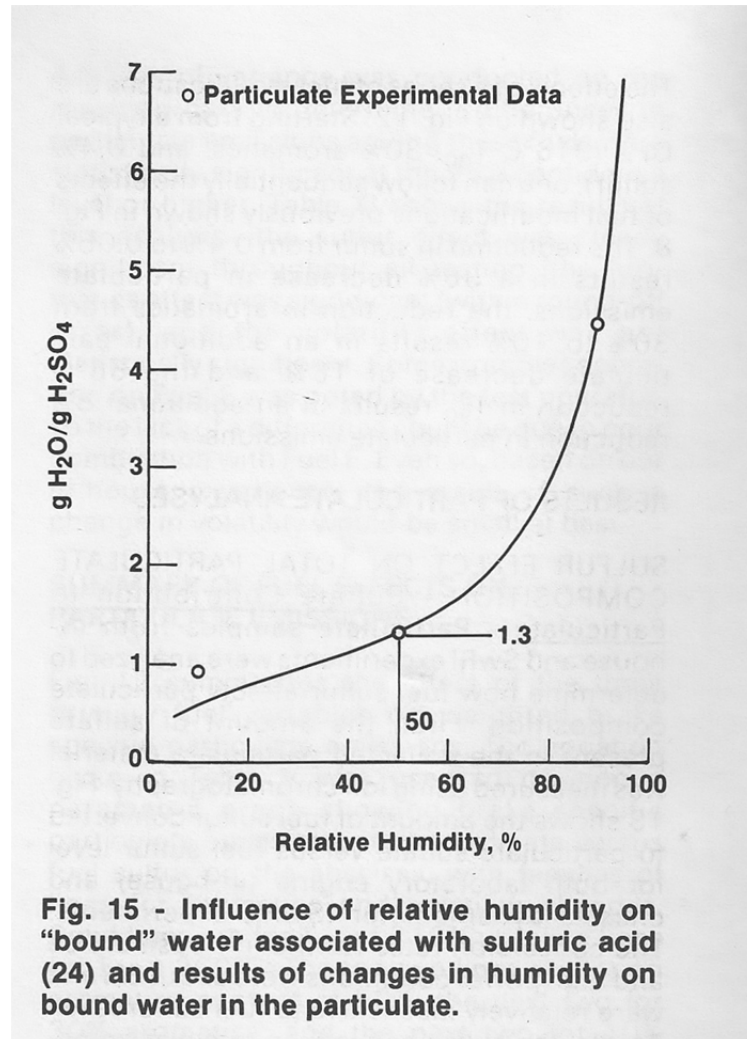

Fig. 16 - Effect of sulfuric-acid doping of particulate filters on the mass of collected soluble organic material at the cruise condition for both primary and backup particulate filters.

Furthermore, because the sulfuric acid component of particulate is hygroscopic and the amount of water bound to each sulfuric acid depends on relative humidity, any variations in humidity and temperature during the filter weighing process can change the measured PM mass (Figure A2-4).

Figure A2-4: Influence of relative humidity on mass of “bound” water associated with sulfuric acid and contributing to total PM. (Figure 15, Wall (1984))



The unregulated emissions consist of hydrocarbons and particulates that are divided into more than 100 categories to identify individual unregulated compounds of interest. **Tables A1** and **A3** report a partial list of the more than 700 unregulated compounds that were sampled for during the ACES Phase 1 program. **Figure A2-5** identifies the exhaust sampling measurement methods for the regulated and unregulated compounds assessed in ACES.

Figure A2-5: Overall experimental setup for the ACES program (Figure 1 from Khalek et al. (2011))

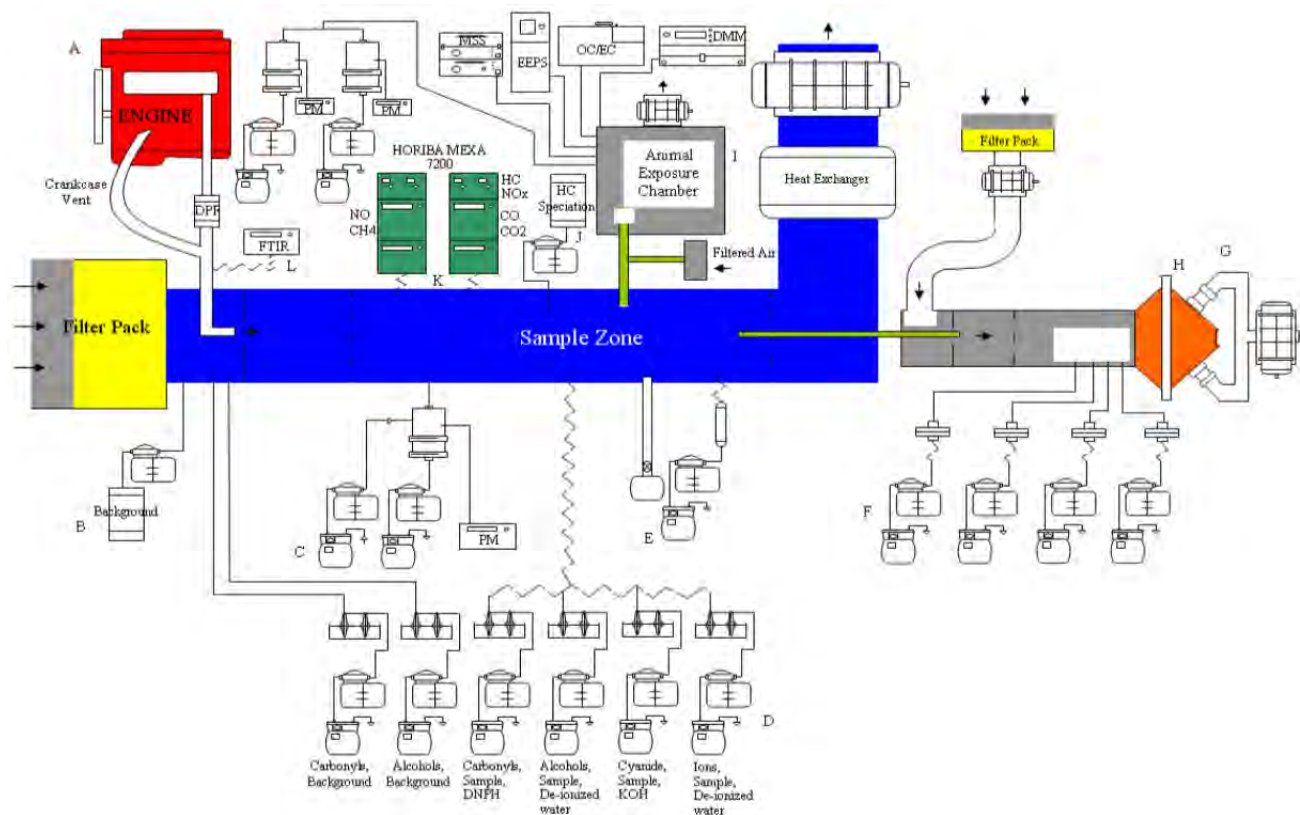

For an explanation of this figure, the following is the figure caption taken directly from the Khalek et al. (2011) reference:

- A: 2007 heavy-duty diesel engine with aftertreatment
- B: background bag sample of dilution air for CO, CO₂, NO_x, NO, THC_s, CH₄, and C₂–C₁₂ speciation.
- C: regulated PM following CFR Part 1065 using 47-mm Teflo filter.
- D: impingers for carbonyls, alcohols, ions, and cyanide ion.
- E: sorbent traps for nitrosamines and Summa canister for SVOCs.
- F: auxiliary PM samples on 47-mm filters for inorganic ions (Fluoropore filter), XRF (Teflo filter), and inductively coupled MS (Fluoropore filter), DFI/GC (TX-40 filter).

- G: XAD traps for gas-phase semi-volatile compounds: PAHs, oxy-PAHs, nitro-PAHs, hopanes, steranes, carpanes, polar organics, highmolecular- weight alkanes and cycloalkanes, dioxins, furans.*
- H: filter (8-10 inch Zefluor) for particulate-phase semi-volatile compounds: PAHs, oxy-PAHs, nitro-PAHs, dioxins, furans, hopanes, steranes, carpanes, polar organics, high-molecular-weight alkanes, cycloalkanes, dioxins, and furans*
- I: UAEC PM mass using Teflo filter, OC/EC collection using a pair of quartz filters, size and number using EEPS, real-time total PM using DMM-230, real-time soot using MSS (Microsoot Sensor).*
- J: proportional bag sample for hydrocarbon speciation of C₂–C₁₂ compounds.*
- K: Horiba MEXA 7200 for THCs, CO, CO₂, NO_x, NO analyzer, and CH₄ analyzer.*
- L: FTIR for N₂O*

Emissions sampling to identify unregulated compounds is more complex, expensive and time-consuming than is the sampling of regulated compounds. The published works of leading investigators (Liu (2010), Clark (2006), Haupt (2004), Schauer (1999), Ullman (1998), Mitchell (1994), Liotta (1993), Rogge (1993), and Westerholm (1991)) detail the increased complexity of measuring unregulated emission species. In addition, Khalek et al. (2011) provides details of how each of the above noted steps A-L were executed. Liu provides a list of diesel exhaust unregulated emissions compounds (from engine-out, DPF-out, and SCR-out, respectively) similar to that of Khalek, and explains sampling methods in detail that are similar to Hildemann et al. (1989, 1991), Kleeman et al. (2000), and Kweon et al. (2002, 2003), but with significant improvements (from partial-full-partial to full-partial-full source dilution sampling system to improved representative sampling). However, the Liu et al. (2008a) sampling method was different from that of Khalek and Liu's measurements were performed independently from ACES.

The following description of measurement methods is from Liu et al. (2010):

“Engine exhaust samples were collected with a source dilution sampling (SDS) system which consisted of a constant volume primary dilution tunnel, a secondary micro-diluter, a residence time chamber (RTC), isokinetic sampling probes, multiple sampling trains, and control devices. A detailed discussion of the design, operating principles, and quality assurance and quality control (QA/QC) procedures for the SDS system can be found in the literature (Liu et al., 2008a). In summary, HEPA filters and activated carbon removed

particles and organic compounds, respectively, from the dilution air prior to mixing with the engine exhaust. The dilution air had significantly lower particle number concentrations than the ambient air of the Emissions Laboratory, according to the measurements from the Scanning Mobility Particle Sizer (SMPS). The mixture of dilution air and engine exhaust was further diluted to simulate atmospheric conditions and sampled with a full-partial flow method to minimize particle loss. A variety of media were used for sample collection including baked quartz filters, polytetrafluoroethylene (PTFE) membrane filters, XAD resin cartridges, polyurethane foam (PUF), thermal desorption (TD) tubes, and dinitrophenylhydrazine (DNPH) cartridges. Upstream of the sample collection media, PM_{2.5} cyclone separators pre-classified the PM in the exhaust flow. Fig. 1a shows the testing setup and the components of the SDS system, while Fig. 1b shows the sampling train configurations and collection media. Before testing, the system was cleaned and the substrates were prepared according to applicable QA/QC practices.”

Table A2-1 (Table 1 from Khalek et al. (2011)) reports the sampling method categories for chemical characterization determination. ACES Phase 1 included all of the chemical sample collection noted in **Table A2-1** except the last category, particle phase urea compounds, because 2007 engines did not include SCR aftertreatment (Khalek et al. (2011)).

Table A2-1: sampling/analysis matrix for regulated and unregulated emissions on each ACES engine

Parameter; Analytical Method(s)	Media	FTP Hot Start- W/O Blowby	FTP Hot Start- W Blowby	CARBz- ICT	CARBz- CH	16-Hr Transient Cycle	Tunnel Blank	16-Hr Tunnel Background	Background Corrected ^a ?
Total Hydrocarbon (THC)	FID	3	3	2	2	3	3	0	Yes
Oxides of Nitrogen (NO _x)	Chemiluminescent	3	3	2	2	3	3	0	Yes
Carbon Monoxide (CO)	NDIR	3	3	2	2	3	3	0	Yes
Particulate Matter (PM)	47 mm Teflon [®] membrane filter	3	3	2	2	3	3	0	No
NO ₂	Chemiluminescent	3	3	2	2	3	3	0	Yes
N ₂ O	FTIR	3	3	2	2	3	3	0	No
OC/EC	Quartz filter	3	3	2	2	3	3	0	No
Particle Size and Number	EEPS	3	3	2	2	3	3	0	No
Real Time PM	DMM-230	3	3	2	2	3	3	0	No
Metals, elements; ICP/MS	Fluoropore [®] filter + DI Water Impinger	3	3	2	2	3	3	0	No
Ca, P, S, K, Fe, Si, Na; EDXRF	Fluoropore [®] filter	3	3	2	2	3	3	0	No
Inorganic ions and acids; IC	Fluoropore [®] filter + DI Water Impinger	3	3	2	2	3	3	0	No
pH, H ⁺ ; pH, Titration	DI Water Impinger	3	3	2	2	3	3	0	No
Cyanide, Cr(VI); GC-ECD, ICP/MS	KOH Impinger	3	3	2	2	3	3	0	No
SO ₂ ; IC	H ₂ O ₂ Impinger	3	3	2	2	3	3	0	No
Gas phase hydrocarbons (C ₂ -C ₁₂); GC-FID	Tedlar [®] Bag	3	3	2	2	3	3	0	Yes
Carbonyl compounds; HPLC-UV	DNPH Impinger	3	3	2	2	3	3	0	Yes
Alcohols; GC-FID	DI Water Impinger	3	3	2	2	3	3	0	Yes
Dioxins and Furans; HRGC/HRMS	Zefluor [®] Filter + XAD [®] Cartridge	0	0	0	0	1	0	1	Yes
Selected VOCs; GC/MS	SUMMA [®] Canister	3	3	2	2	1	3	0	No
PAH; GC/MS	Zefluor [®] Filter + XAD [®] Cartridge	3	3	2	2	3	3	1	No
nitroPAH; GC/MS		3	3	2	2	1	3	1	No
Hopane/Steranes/Carpanes; GC/MS		3	3	2	2	3	3	0	No
Alkanes, Alkenes, Alkynes, Cyclo- and branched (C ₁₄ -C ₄₀); GC/MS		3	3	2	2	1	3	0	No
Polar compounds, Oxygenated PAH, Organic Acids; GC/MS		3	3	2	2	1	3	1	No
Nitrosamines; GC/MS	Thermosorb [®]	3	3	2	2	1	3	0	No

^a Background corrected means that a sample of the background dilution air taken from downstream of the HEPA filter in the CVS tunnel is analyzed for the same species concentration measured in the dilute exhaust, and then subtracted from the dilute exhaust species concentration using the following equation: $X_{bgc} = X_m - (1-1/DR) * X_{bg}$, where X_{bgc} is the corrected concentration, X_m is the measured concentration, and X_{bg} is the background concentration of the species of interest.

Liu et al. (2010) and Khalek et al. (2011) both described the independent, state-of-the-art laboratories that performed the detailed chemical analyses. Those laboratories, including Desert Research Institute, Wisconsin State Laboratory of Hygiene and SwRI have considerable expertise in identifying the specific compounds of interest.

Another complex issue relating to unregulated emissions is particle number count and size distribution measurements. The complexity is due to the basic characteristics of aerosols (Friedlander (2000); Fuchs (1964); Hinds (1982)) and the manner in which exhaust particles are influenced by engine operating conditions. Examples of test conditions that impact particle size and number count are catalyst formulation, fuel quality, sample temperature, dilution rate and ratio, and engine operating conditions, whether steady-state, transient, increasing or decreasing engine speed and power.

Descriptions of particle measurement methods and typical results are provided by Khalek et al.(2011), Liu et al. (2007a, 2007b), Kittelson et al. (2005a, 2005b, 2006), Vaaraslahti et al. (2004), Liu et al. (2003, 2002), Holmen et al. (2002), Chatterjee et al. (2002), Zheng et al (2012), and Mader and Pankow (2000, 2001).

It should be noted that the ACES Phase 1 tests were carried out with state of the art equipment and sampling techniques using lessons learned from testing in the regulatory environment and involving chemical analysis laboratories that were also very sophisticated. Similar due diligence has been taken with the ACES Phase 3 animal studies although it is not possible to directly use procedures that satisfy regulatory protocol. This type of effort is rare in general exposure studies of the past and data from those studies should be evaluated with that in mind.

APPENDIX 2 REFERENCES

1. Bedick, C., Clark, N., Zhen, F., Atkinson, R., and McKain D. (2009). Testing of a Heavy Heavy-Duty Diesel Engine Schedule for Representative Measurement of Emissions; J. Air & Waste Manage. Assoc., 2009, 59, 960-971; doi: 10.3155/1047-3289.59.8.960.
2. Chase, R.E. and Duszkievicz, G.J. (2004). PM Measurement Artifact: Organic Vapor Deposition on Different Filter Media, SAE Paper 2004-01-0967, Warrendale, PA.
3. Chatterjee, S., Conway, R., Lanni, T., Frank, B., Tang, S., Bush, C., Lowell, D., Evans, J., McClean, R., and Levy, S.J. (2002). Performance and Durability Evaluation of Continuously Regenerating Particulate Filters on Diesel Powered Urban Buses at NY City Transit, Part II, SAE Paper 2002-01-0430, Warrendale, PA.
4. Clark, N.N., Gautam, M., Wayne, W.S., Thompson, G.J., Nine, R.D., Lyons, D.W., Buffamonte, T., and Xu, S. (2006). Regulated Emissions from Heavy-Duty Diesel Trucks Operating in the South Coast Air Basin, SAE Paper 2006-01-3395, Warrendale, PA.
5. Clark, N., Kern, J., Atkinson, C., and Nine, R. (2002). Factors Affecting Heavy-Duty Diesel Vehicle Emissions, J. Air and Waste Manage. Assoc., 52:1, 84-94 (2002).
6. DieselNet (2012), <http://www.dieselnet.com/standards/cycles/index.php>
7. Finlayson-Pitts, B.J., and Pitts, J.N. (2000). Chemistry of Upper and Lower Atmosphere: Theory, Experiments, and Applications, Academic Press, 2000.
8. Friedlander, S.K. (2000). *Smoke, Dust and Haze, Fundamentals of Aerosol Dynamics*, Oxford University Press, New York, ISBN 0-19-512999-7 (2000).
9. Fuchs, N.A. (1964). *The Mechanics of Aerosols*, Pergamon Press., London, DOI: 10.1002/qj.49709138822 (1964).
10. Haupt, D., Nord, K., Egeback, K.E., and Ahlvik, P. (2004). Hydrocarbons and Aldehydes from a Diesel Engine Running on Ethanol and Equipped with EGR, Catalyst and DPF, SAE Paper 2004-01-1882, Warrendale, PA.
11. Hildemann, L.M., Cass, G.R., and Markowski, G.R. (1989). A Dilution Stack Sampler for Collection of Organic Aerosol Emissions: Design, Characterization and Field Tests, Aerosol Sci. Technol. 10:193–204 (1989).

12. Hildemann, L.M., Markowski, G.R., and Cass, G.R. (1991). Chemical Composition of Emissions from Urban Sources of Fine Organic Aerosol, *Environ. Sci. Technol.* 25(4):744–759 (1991).
13. Hinds, W.C. (1982). *Aerodol Technology, Properties, Behavior, and Measurement of Airborne Particles*, John Wiley & Sons, New York, ISBN-10: 0471194107, ISBN-13: 978-0471194101 (1982).
14. Holmen, B.A. and Ayala, A. (2002). Ultrafine PM Emissions from Natural gas, Oxidation-Catalyst Diesel, and Particle Trap Diesel Heavy-Duty Transit Buses, *Environ. Sci. & Technol.* 36:23, 5041-5050 (2002).
15. Johnson, J. (1994). A Review of Diesel Particulate Control Technology and Emissions Effects, 1992 Horning Memorial Award Lecture, SAE 1994-0233 (1994).
16. Khalek, Bougher, Merritt, and Zielinska (2011). Regulated and Unregulated Emissions from Highway Heavy-Duty Diesel Engines Complying with U.S. Environmental Protection Agency 2007 Emissions Standards, *J. Air and Water Management Association*, 61, 427-442, (2011); DOI: 10.3155/1047-3289.61.4.427, ISSN:1047-3289.
17. Khalek, I.A. (2007). Diesel Particulate Measurement Research Project E-66, Report for Coordinating Research Council, Inc., U.S. Department of Energy/National Renewable Energy Laboratory, Engine Manufacturers Association, U.S. Environmental Protection Agency, California Air Resources Board, 2007.
18. Kittelson, D.B., Arnold, M., et al. (1999). Review of Diesel Particulate Matter Sampling Methods: Final Report, Report to U.S. EPA, 1999.
19. Kittelson, D.B. and Johnson, J.H.(1991). Variability in Particle Emission Measurements in the Heavy Duty Transient Test, SAE Paper 910738, Warrendale, PA.
20. Kittelson, D.B. and Watts, W.F. (2005a). On-road and Laboratory Evaluation of Combustion Aerosols, Part 1. Summary of Diesel Engine Results, *J. Aerosol. Science*, 37,913-930, (2005); doi:10.1016/j.jaerosci.2005.08.005.
21. Kittelson, D.B., Watts, W.F., Johnson, J.P., Rowntree, C., Payne, M., Goodier, S., Warrens, C., Preston, H., Zink, U., Ortiz, M., Goersmann, C., Twigg, M.V., Walker, A.P., and Caldwell, R. (2005b). On-road Evaluation of Two Diesel Aftertreatment Devices, *J. Aerosol. Science*, doi:10:1016/jaerosci.2005.11.003.

22. Kittelson, D.B., Watts, W.F., Johnson, J.P., Rowntree, C., Goodier, S., Payne, M., Preston, H., Warrens, C., Ortiz, M., Zink, U., Goersmann, C., Twigg, M.V., and Walker, A.P. (2006). Driving Down On-highway Particulate Emissions, SAE Paper 2006-01-0916, Warrendale, PA.
23. Kleeman, M.J., Schauer, J.J., and Cass G.R. (2000). Size and Composition Distribution of Fine Particulate Matter Emitted from Motor Vehicles, *Environ. Sci. Technol.* 34(7):1132–1142 (2000).
24. Kweon, C.B., Foster, D.E., Schauer, J.J., and Okada, S. (2002). Detailed Chemical Composition and Particle Size Assessment of Diesel Engine Exhaust, SAE Paper 2002-01-2670, Warrendale, PA.
25. Kweon, C.B., Okada, S., Foster, D.E., Bae, M., and Schauer, J.J. (2003). Effect of Engine Operating Conditions on Particle-Phase Organic Compounds in Engine Exhaust of a Heavy-Duty Direct-Injection (D.I.) Diesel Engine, SAE Paper 2003-01-0342, Warrendale, PA.
26. Liotta, F.J., and Montalvo, D.M. (1993). The Effect of Oxygenated Fuels on Emissions from a Modern Heavy-Duty Diesel Engines, SAE Paper 932734, Warrendale, PA.
27. Liu, Z.G., Verdegan, B.M., Badeau, K.A., and Sonsalla, T.P. (2002). Measuring the Fractional Efficiency of Diesel Particulate Filters, SAE Paper 2002-01-1007, Warrendale, PA.
28. Liu, Z.G., Skemp, M.D., and Lincoln, J.C. (2003). Diesel Particulate Filters: Trends and Implications of Particle Size Distribution Measurement, SAE Paper 2003-01-0046, Warrendale, PA.
29. Liu, Z.G., Vasys, V.N., and Kittelson, D.B. (2007a). Nuclei-mode Particle Emissions and their Response to Fuel Sulfur Content and Primary Dilution During Transient Operations of Old and Modern Diesel Engines, *Environ. Sci. & Technol.*, 41:18, 6479-6483 (2007).
30. Liu, Z.G., Ford, D.C., Vasys, V.N., Chen, D-R., and Johnson, T.R. (2007b). Influence of Engine Operating Conditions on Diesel Particulate Matter Emissions in Relation to Transient and Steady-State Conditions, *Environ. Sci. & Technol.*, 41:13, 4593-4599 (2007); doi:10.1021/es0616229.

31. Liu, Z.G., Swor, T.A., Schauer, J.J., DeBilzen, J., and Severance, C. (2008a). A source dilution sampling system for characterization of engine emissions under transient or steady-state operation, *Aerosol Science and Technology*, 42, 270-280 (2008).
32. Liu, Z.G., Berg, D.R., Swor, T.A., and Schauer, J.J. (2008b). Comparative Analysis on the Effects of Diesel Particulate Filter and Selective Catalytic Reduction Systems on a Wide Spectrum of Chemical Species Emissions, *Environ. Sci. Technol.*, 42, 6080-6085 (2008).
33. Liu, Z.G., Berg, D.R., and Schauer, J.J. (2008c). Effects of a zeolite-selective catalytic reduction system on comprehensive emissions from a heavy-duty diesel engine. *Journal of the Air and Waste Management Association* 58, 1258-1265 (2008).
34. Liu, Z.G., Vasys, V.N., Dettmann, M.E., Schauer, J.J., Kittelson, D.B., and Swanson, J. (2009). Comparison of Strategies for the Measurement of Mass Emissions from Diesel Engines Emitting Ultra-Low Levels of Particulate Matter”, *Aerosol Sci. & Technology*, 43:11, 1142-1152, (2009); DOI: 10.1080/027/02786820903219035.
35. Liu, Z.G., Berg, D.R., Swor, T.A., Schauer, J.J., and Zielinska, B. (2009b). A Study on the Emissions of Chemical Species from Heavy-Duty Diesel Engines and the Effects of Modern Aftertreatment Technology, SAE Paper 2009-01-1084, Warrendale, PA.
36. Liu, Z.G., Berg, D.R., Vasys, V.N., Dettmann, M.E., Zielinska, B., and Schauer, J.J. (2010). Analysis of C1, C2 and C10 through C33 particle-phase and semi-volatile organic compound emissions from heavy-duty diesel engines, *Atmos. Environ* 44, 1108-1115 (2010).
37. Mader, B.T. and Pankow, J.F. (2000). Gas/solid partitioning of semi-volatile organic compounds (SOCs) to air filters. 1. Partitioning of polychlorinated dibenzodioxins, polychlorinated dibenzofurans and polycyclic aromatic hydrocarbons to Teflon membrane filters, *Atmospheric Environment*, 34, 4879-4887 (2000).
38. Mader, B.T. and Pankow, J.F. (2001). Gas/solid partitioning of semi-volatile organic compounds (SOCs) to air filters. 3. An Analysis of Gas Adsorption Artifacts in Measurements of Atmospheric SOCs and Organic Carbon (OC) When Using Teflon Membrane Filters and Quartz Fiber Filters, *Environ. Sci. Technol.* 35, (2001).
39. Mauderly, J.L., Snipes, M.B., Barr, E.B., Belinsky, S.A., Bond, J.A., Brooks, A.L., Chang, I.Y., Cheng, Y.S., Gillett, N.A., Griffith, W.C., Henderson, R.F., Mitchell, C.E., Nikula, K.J., and D.G. Thompson, D.G. (1994). Part I, “Neoplastic and non-neoplastic lung

- lesions. In: Pulmonary Toxicity of Inhaled Diesel Exhaust and Carbon Black in Chronically Exposed Rats,' Research Report 68, Health Effects Institute, Cambridge, MA.
40. McDow, S.R. and Huntzicker, J.J. (1990). Vapor Adsorption Artifact in the Sampling of Organic Aerosol: Face Velocity Effects, *Atmospheric Environment*, 24A (1990).
 41. Mitchell, K., Steere, D.E., Taylor, J.A., Manicom, B., Fisher, J.E., Sienicki, E.J., Chiu, C., and Williams, P. (2003). Impact of Diesel Fuel Aromatics on Particulate PAH and Nitro-PAH Emissions, SAE Paper 942053, Warrendale, PA.
 42. Park K., Kittelson, D.B., and McMurry, P. (2003). A closure study of aerosol mass concentration measurements: comparison of values obtained with filters and by direct measurements of mass distributions, *Atmospheric Environment*, 37 (2003).
 43. Rogge, W.F., Hildemann, L.M., Mazurek, M.A., and Cass, G.R. (1993). Sources of Fine Organic Aerosol. 2. Non-Catalyst and Catalyst-Equipped Automobiles and Heavy-Duty Diesel Trucks, *Environ. Sci. & Technol.*, 27:4 636-651 (1993).
 44. Schauer, J.J., Kleeman, M.J., Cass, G.R., and Simoneit, B.R.T. (1999). Measurement of Emissions from Air Pollution Sources, C1 through C30 Organic Compounds from Medium Duty Diesel Trucks, *Environ. Sci. & Technol.*, 33:10, 1578-1587 (1999).
 45. Stein, H.J., Ekermo, A.I., and Treiber, P.J.H. (1989). Emissions Correlation of Heavy-Duty Transient Test Facilities, SAE Paper 892492, Warrendale, PA.
 46. Storey, M.E., Luo, W., et al. (1995). Gas/solid partitioning of semi-volatile organic compounds (SOCs) to model atmospheric solid surfaces as a function of relative humidity. 1. Clean Quartz, *Environ. Sci. Technol.*, 29, 2420-2428 (1995).
 47. U.S. EPA (2004). Protection of Environment, Code of Federal Regulations, Part 86; Title 40; U.S. Government Printing Office: Washington, DC, 2004.
 48. U.S. EPA (2010). U.S.EPA Title 40, Protection of Environment, Code of Federal Regulations, Chapter I, Subchapter U, Part 065, Engine Testing Procedures, ; Title 40; U.S. EPA, Washington, DC, 2010, <http://www.epa.gov/nvfel/testing/regulations.htm>, at this EPA site, select the 1065 option.
 49. Ullman, T.L. (1998). Investigation of the Effects of Fuel Composition on Heavy-Duty Diesel Engine Emissions, SAE Paper 982072, Warrendale, PA.

50. Vaaraslahti, K., Virtanen, A., Ristimäki, J., and Keskinen, J. (2004). Nucleation Mode Formation in Heavy-Duty Diesel Exhaust with and Without a Particulate Filter, *Environ. Sci & Technol.*, 38:18, 4884-4899 (2004); doi:10.1021/es0353255.
51. Verbeek, R.P., Ligterink, N.E., and Dekker, H.J. (2008). Correlation Factors between European and World Harmonized Test Cycles for heavy duty-engines, TNO Report MON-RPT-033-DTS-2008-03854, TNO Science and Industry (2008).
52. Wall, J. and Hoekman, S. (1984). Fuel Composition Effects on Heavy-Duty Diesel Particulate Emissions, SAE Paper 841364, Warrendale, PA.
53. Watts, W.F. and Kittelson, D.B. (2002). Diesel Particulate Matter Sampling Methods Statistical Comparison, Proposal to Diesel Emission Evaluation Program, 2002.
54. Westerholm, R.N., Almen, J., and Li, H. (1991). Chemical and Biological Characterization of Particulate- Semi-volatile and gas-Phase Associated Compounds in Diluted Heavy-Duty Diesel Exhausts: A Comparison of Three Different Semi-volatile-Phase Samplers, *Environ. Sci. & Technol.*, 25:2, 332-345 (1991).
55. Zhang, X.Q. and McMurry, P.H. (1987). Theoretical Analysis of Evaporative Losses from Impactor and Filter Deposits, *Atmospheric Environment*, 21, 1987.
56. Zhen, F., Clark, N., Bedick, C., Gautam, M., Wayne, W., Thompson, G., and Lyons, D. (2009). Development of a Heavy Heavy-Duty Diesel Engine Schedule for Representative Measurement of Emissions, *J. Air & Waste Manage. Assoc.*, 59, 950-959 (2009); doi: 10.3155/1047-3289.59.8.950.
57. Zheng, Z., Durbin, T., Karavakalis, G., Johnson, K., Chaudhary, A., Cocker, D., Herner, J., Robertson, W., Huai, T., Ayala, A., Kittelson, D.B., and Jung, H. (2012). Nature of Sub-23-nm Particles Downstream of the European Particle Measurement Programme (PMP)-Compliant System: A Real-Time Data Perspective, *Aerosol Science and Technology*, online April 23, 2012.

APPENDIX 3 POTENTIALLY CONFOUNDING NITROARENE ARTIFACTS IN DIESEL PARTICULATE SAMPLES

Caution must be used when measuring nitrated polycyclic aromatic hydrocarbons (nitro-PAH) in diesel exhaust streams. Nitro-PAH can form as a result of sampling if PAHs collected on a filter patch are exposed to NO₂ or HNO₃ (Bosch et al. (1985); Gibson et al. (1981); Grimmer et al. (1987); Hartung et al. (1984); Levsen et al. (1988); Saito et al. (1982); Schuetzle and Perez (1983a); Schuetzle (1983b)). By re-exposing filters loaded with diesel soot to filtered exhaust gases, Gibson et al. (1981) observed an increase of 1-nitropyrene by a factor of two, and Saito et al. (1982) by a factor of three, when the filter was re-exposed for 45 minutes. Using similar experiments, Grimmer et al. (1987) observed a substantial nitration on the filter when sampling was done at 100°C. Hartung et al. (1984) observed an 18 percent increase in the concentration of 1-nitropyrene (relative to the PM mass) with increasing sampling time up to 46 minutes. Similar results were reported by Schuetzle and Perez (1983a) and Schuetzle (1983b) who concluded that during a sampling period of 23 minutes, 12% of the observed 1-nitropyrene is due to sampling artifacts. Levsen et al. (1988) have shown that $13.6 \pm 9.5\%$ of 1-nitropyrene measured during diesel engine testing was a result of artifact formation on the filter patch Levsen et al. (1988). These results are in agreement with those of Hartung et al. (1984). Those studies emphasize that short sampling time and dilution (to reduce NO₂ concentration) should be used to minimize artifacts. Carrara et al. (2010a, 2010b, 2011) have attempted to minimize artifact formation by limiting sampling time to 15 or 30 minutes, depending on engine operating condition, and also using annular denuders to remove NO₂ from the gas stream before passing exhaust through the filter media. The authors report that the denuders had NO₂ removal efficiencies of $89\% \pm 6\%$ after 1 hour of usage. However, it typically requires a much longer time for sampling from DPF-out than from engine-out in order to collect sufficient samples for analysis. The effects of nitration and dilution air contamination during sampling cannot be neglected.

A Microtrol 4 microtunnel was used to dilute a partial exhaust sample by Carrara et al. (2010a, 2010b, 2011). Dilution ratios for Carrara's study were between 4 and 6, and a total flow of only 4 liter/min was directed to quartz fiber filters for collection. This low flow was reportedly required in order to effectively remove NO₂ from the exhaust with annular denuders. However, the low flow and low dilution ratio provided additional opportunities for nitration of PAH. In the figures below from Carrara, there is a clear trend toward higher nitration with increasing temperature (up to 100°C) and increasing time, both of which would result from a low dilution ratio and sample flow. Carrara et al. (2010a, 2010b, 2011) do not provide details regarding whether the dilution air is HEPA cleaned and passed through

activated carbon filters to remove particle and organic impurities. Furthermore, there is no discussion of whether the results reported are background dilution air corrected. Thus, the possibility that atmospheric PAH compounds were entrained into the sampling system cannot be ruled out. This could lead to higher PAH concentrations in the DPF, and thus, more n-PAH post-DPF. In comparison, dilution air was HEPA and activated carbon filtered in the study by Liu et al. (2010) and the results were background corrected. Similar approaches were also used by Hu et al. (2012) for studies supported by CARB and Laroo et al. (2011) for studies for EPA.

Figure A3-1

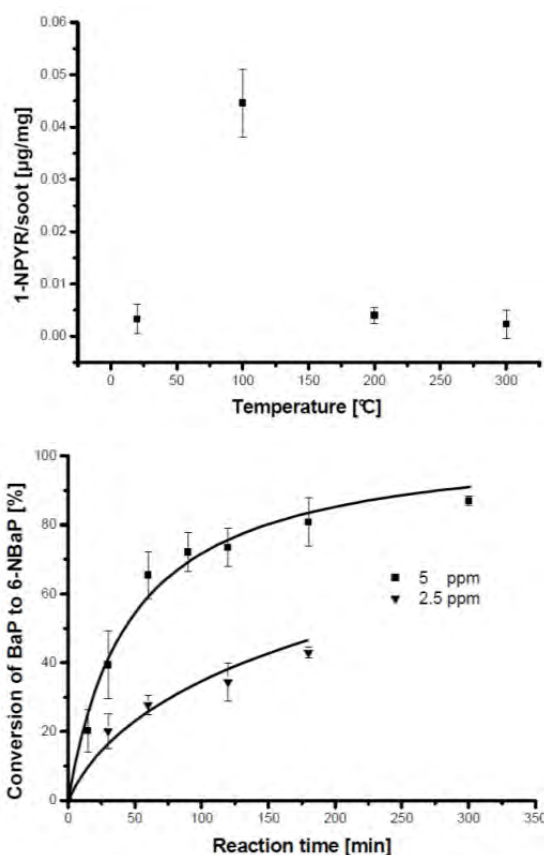

It is well known that nitro-PAHs can be found in ambient air (Arey et al. (1967), Dimashki et al. (2000), Pitts (1967), Zielinska et al. (1989)). Pitts suggests two mechanisms for the formation of particle-bound 2-nitrofluoranthene and gas-phase 2-nitronaphthalene:

1. During daylight, attack on gaseous fluoranthene by OH radicals followed by NO₂ addition, loss of H₂O and condensation on particle surfaces.
2. Reaction of naphthalene with N₂O₅ at night under ambient conditions during which the gaseous NO₃ radical and NO₂ are present in equilibrium with N₂O₅.

When the ambient air is used to dilute exhaust gases for either full proportional or partial dilution sampling, the background n-PAHs can contribute to artifacts, especially during sampling from DPF-out when a much larger amount of exhaust/dilution air mixture is often required in order to collect sufficient samples for analysis. Again, the effects of ambient air contamination during sampling cannot be neglected.

Carrara et al. is not the first researcher to report the conversion of individual PAH into nitro-PAH by a DPF. Heeb et al. (2008, 2010) found that 1- and 2-nitronaphthalene emissions increased by about 20-100% when a DPF was used and that 9-nitrophenanthrene and 9-nitroanthracene were newly formed by DPFs. However, the isolated nitration of singular PAH is not an indicator for the overall toxicity of the complete PAH/nitro-PAH composition of diesel exhaust. Heeb et al. (2008, 2010) also examined the toxicity of exhaust samples with a reporter gene assay, based on the AH-receptor, which is sensitive to many aryl hydrocarbons. They found that the total AHR agonist emissions were 80-90% lower with a DPF, and that the DPF-induced formation of certain nitro-PAH does not outweigh the overall PAH removal benefit of DPFs. In addition, other authors have found similar overall PAH reductions by DPFs (Hu et al. (2012); Khalek et al. (2011); Liu et al. (2010); Laroo et al. (2011)). Of these, Hu et al. (2012) found that aftertreatment reduced equivalent benzo(a)pyrene emissions by >95%, suggesting a substantial health benefit. Thus, while it is possible that individual nitro-PAH may be formed in DPFs depending on engine operating conditions and emissions characteristics, the overall PAH/nitro-PAH toxicity of diesel exhaust is significantly reduced by the inclusion of a DPF.

APPENDIX 3 REFERENCES

1. Arey, J., Zielinska, B., Atkinson, R., Winer, A., Ramdahl, T., and Pitts, J. N. (1967). The formation of nitro-PAH from the gas-phase reactions of fluoranthene and pyrene with the OH radical in the presence of NO_x, *Atmos. Environ.* 20: 2339 (1967).
2. Bosch, L.C. and White, C. M. (1985). *Nitrated polycyclic aromatic hydrocarbons*, Huthig Pub. Ltd. (1985).
3. Carrara, M. (2010a). *Formation of nitrated polycyclic aromatic hydrocarbons in diesel particulate filters: laboratory experiments and test-bench measurements*. PhD Dissertation (2010).
4. Carrara, M., Wolf, J-C., and Niessner, R. (2010b). Nitro-PAH formation studied by interacting artificially PAH-coated soot aerosol with NO₂ in the temperature range of 295-523K, *Atmos. Environ.*, 44: 3878 (2010).
5. Carrara, M. and Niessner, R. (2011). Impact of a NO₂-regenerated diesel particulate filter on PAH and NPAH emissions from an EURO IV heavy duty engine. *J. Environ. Monit.*, 13, 3373–3379 (2011).
6. Clark, N., Kern, J., Atkinson, C., and Nune, R. (2002). Factors Affecting Heavy-Duty Diesel Vehicle Emissions, *J. Air and Waste Manage. Assoc.*, 52:1, 84-94 (2002).
7. Dimashki, M., Harrad, S., and Harrison, R.M. (2000). Measurements of nitro-PAH in the atmospheres of two cities, *Atmos. Environ.* 34: 2459 (2000).
8. Gibson, T.L., Ricci, A., and Williams, R. (1981). In: Cooke, M.; Dennis, AJ (eds), *Polynuclear Aromatic Hydrocarbons*, Battelle Press, p707 (1981).
9. Grimmer, G., Jacob, J., Dettbarn, G., and Naujak, K. (1987). In: *Polynuclear Aromatic Hydrocarbons*, Battelle Press (1987).
10. Hartung, A., Kraft, J., Schulze, J., Kieb, H., and Lies, K. (1984). The identification of nitrated polycyclic aromatic hydrocarbons in diesel particulate extracts and their potential formation as artifacts during particulate collection, *Chromatographia* 19: 269 (1984).
11. Heeb, N.V., Schmid, P., Kohler, M., Gujer, E., Zennegg, M., Wenger, D., Wichser, A., Ulrich, A., Gfeller, U., Honegger, P., Zeyer, K., Emmenegger, L., Petermann, J.-L., Czerwinski, J., Mosimann, T., Kasper, M., and Mayer, A. (2008). Secondary effects of

catalytic diesel particulate filters: conversion of PAHs versus formation of nitro-PAHs, *Environ. Sci. Technol.*, 42, 3773 (2008).

12. Heeb, N.V., Schmid, P., Kohler, M., Gujer, E., Zennegg, M., Wenger, D., Wichser, A., Ulrich, A., Gfeller, U., Honegger, P., Zeyer, K., Emmenegger, L., Petermann, J.-L., Czerwinski, J., Mosimann, T., Kasper, M., and Mayer, A. (2010). Impact of low- and high-oxidation Diesel Particulate Filters on genotoxic exhaust constituents, *Environ. Sci. Technol.*, 44, 1078 (2010).
13. Hu, S., Herner, J., Robertson, W., Kobayashi, R., Chang, M.O., Huang, S., Zielinska, B., Kado, N., Rieger, P., Collins, J., Huai, T., and Ayala, A. (2012). Emissions of polycyclic aromatic hydrocarbons (PAH) and nitro-PAHs from heavy-duty diesel vehicles with DPF and SCR, *J. Air Waste Manage.*, in review/press (2012).
14. Khalek, I.A., Bougher, T.L., Merritt, P.M., and Zielinska, B. (2011). Regulated and unregulated emissions from highway heavy-duty diesel engines complying with U.S. Environmental Protection Agency 2007 emission standards. *J. Air Waste Manage. Assoc.*, 61, 427 (2011).
15. Laroo, C.A., Schenk, C.R., Sanchez, L.J., and McDonald, J. (2011). Emissions of PCDD/Fs, PCBs, and PAHs from a modern diesel engine equipped with catalyzed emission control systems, *Environ. Sci. Technol.*, 45, 6420 (2011).
16. Levsen, L., Puttins, U., Schilhabel, J., and Prieb, B. (1988). Artifacts during the sampling of nitro PAHs of diesel exhaust, *Fresenius Z Anal. Chem.*, 330, 527 (1988).
17. Liu, Z.G., Berg, D.R., Vasys, V.N., Dettmann, M.E., Zielinska, B., and Schauer, J.J. (2010). Analysis of C₁, C₂, and C₁₀ through C₃₃ particle-phase and semi-volatile organic compound emissions from heavy-duty diesel engines, *Atmos. Environ.*, 44, 1108 (2010).
18. Pitts, J.N. (1967). Nitration of gaseous polycyclic aromatic hydrocarbons in simulated and ambient urban atmospheres: A source of mutagenic nitroarenes, *Atmos. Environ.*, 21, 2531 (1967).
19. Saito, T., Tokura, N., and Katoh, T. (1982). Analysis of factors affecting the formation of major mutagenic substances in diesel particulate extracts, SAE Paper 821244, Warrendale, PA.

20. Schuetzle, D. and Perez, J.M. (1983a). Factors influencing the emissions of nitrated polynuclear aromatic hydrocarbons (nitro PAH) from diesel engines. *J. Air Pollut. Control Assoc.*, 33, 751 (1983).
21. Schuetzle, D. (1983b). Sampling of vehicle emissions for chemical analysis and biological testing, *Environ. Health Perspect.*, 47, 65 (1983).
22. Zielinska, B., Arey, J., Atkinson, R., and McElroy, P.A. (1989). Formation of methylnitronaphthalenes from the gas-phase reactions of 1- and 2-methylnaphthalene with OH radicals and N₂O₅ and their occurrence in ambient air, *Environ. Sci. Technol.*, 23, 723 (1989).

A global and historical perspective on the exposure characteristics of traditional and new technology diesel exhaust

Impact of technology on the physical and chemical characteristics of diesel exhaust emissions



ISBN 978-2-87567-000-7



9 782875 670007 >